

# Experiences from five years of DP software testing

Øyvind Smogeli

Vestre Rosten 77  
NO-7075 Tiller, Norway  
[www.marinecybernetics.com](http://www.marinecybernetics.com)



# Outline



- Introduction: the complexity of a modern DP system
- HIL testing as a tool for assessing computer control system software
- Experiences from DP system software testing
  - DP-HIL finding statistics
  - PMS-HIL finding statistics
  - Example findings focusing on integration issues

# The DP system

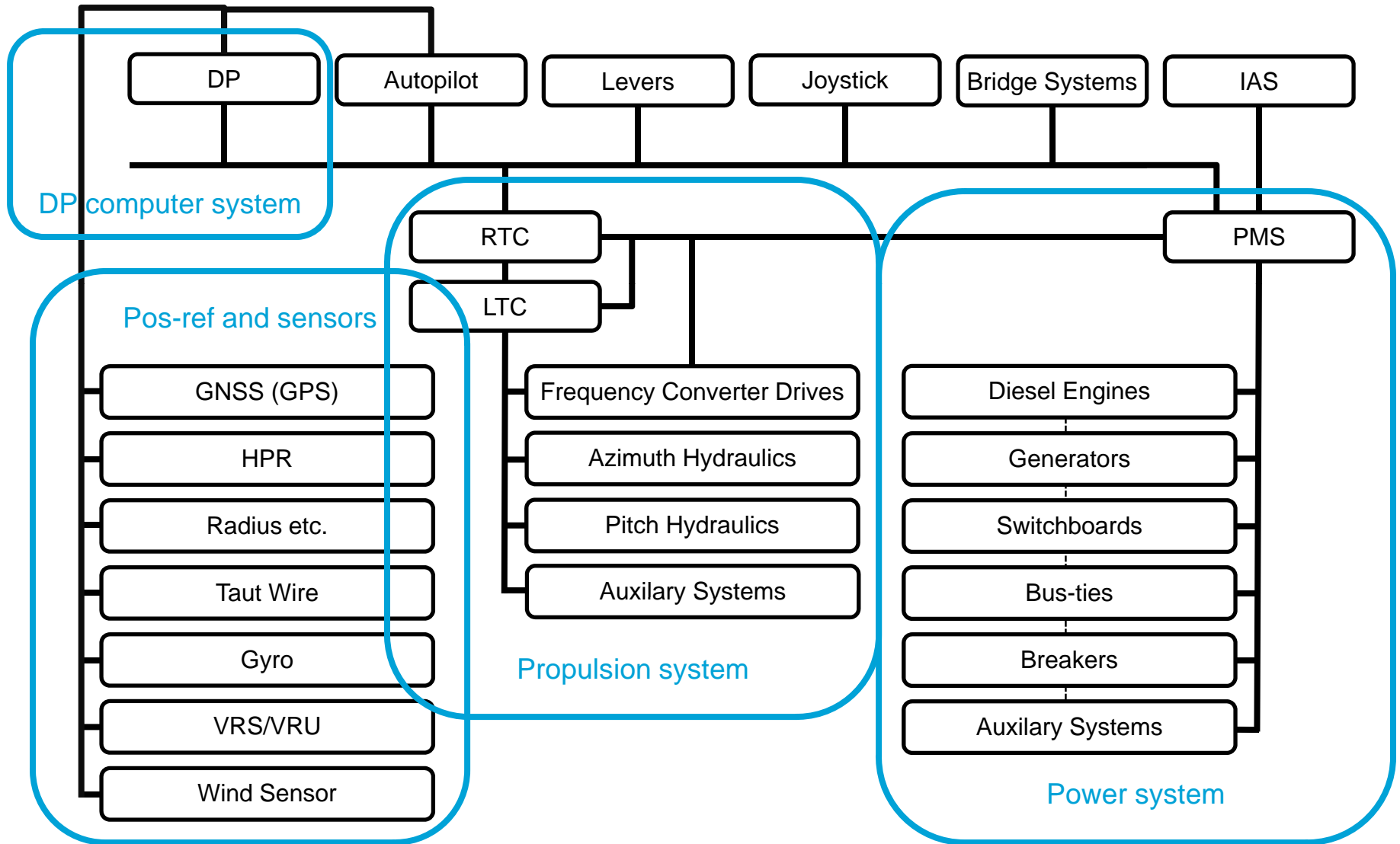

# Distributed functionality

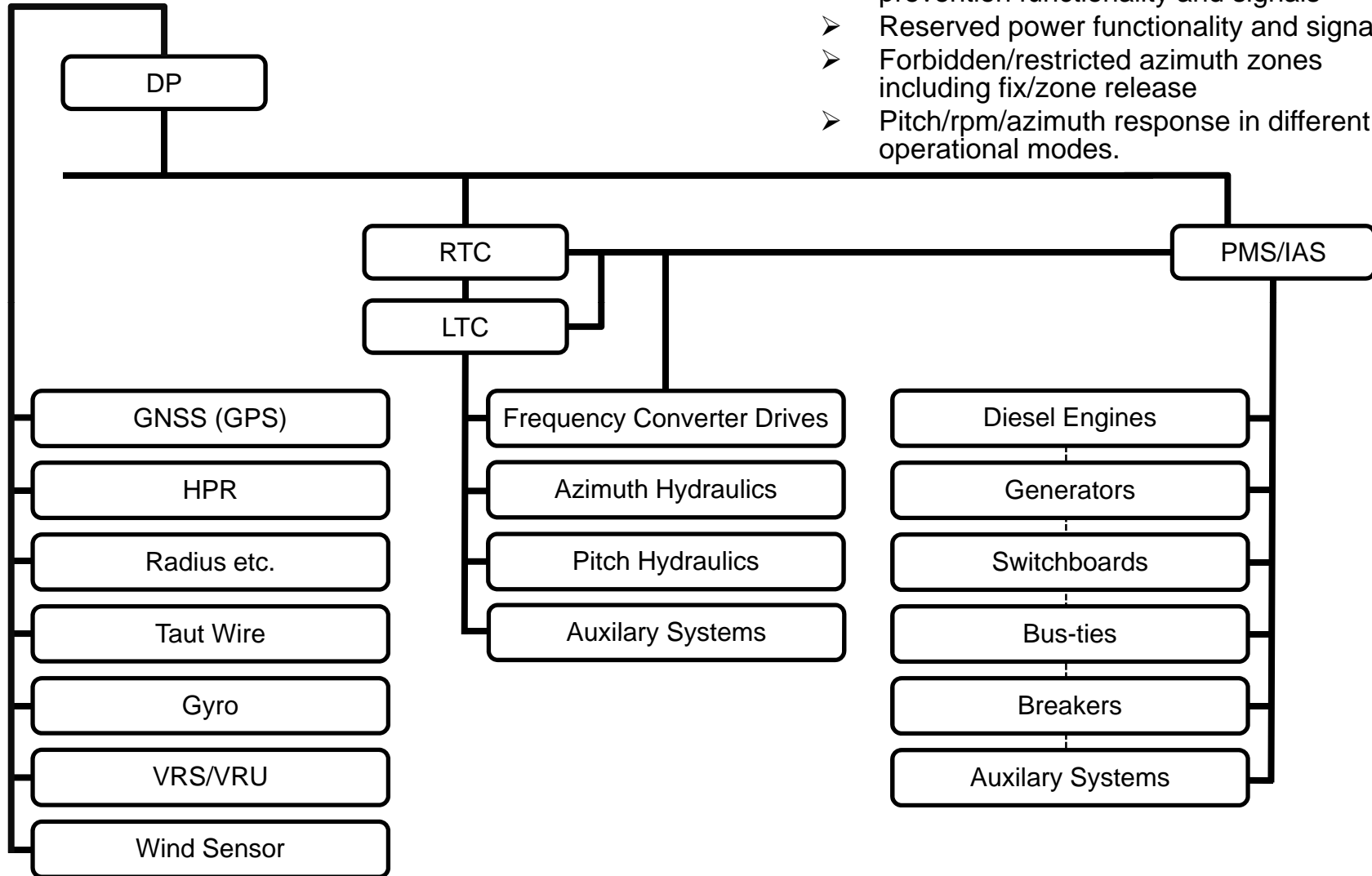

Examples:

- Worst case single failure and associated implementation of the consequence analysis
- Load limitation/reduction and blackout prevention functionality and signals
- Reserved power functionality and signals
- Forbidden/restricted azimuth zones including fix/zone release
- Pitch/rpm/azimuth response in different operational modes.

# HIL testing of DP system software

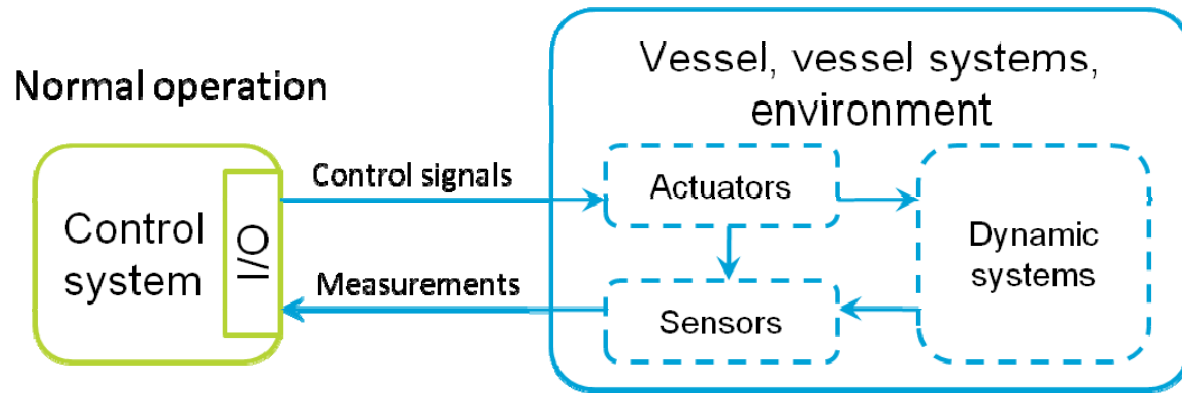

Types of testing:

- Functional testing
- Failure mode testing
- Performance testing
- Integration testing

# DP-HIL testing

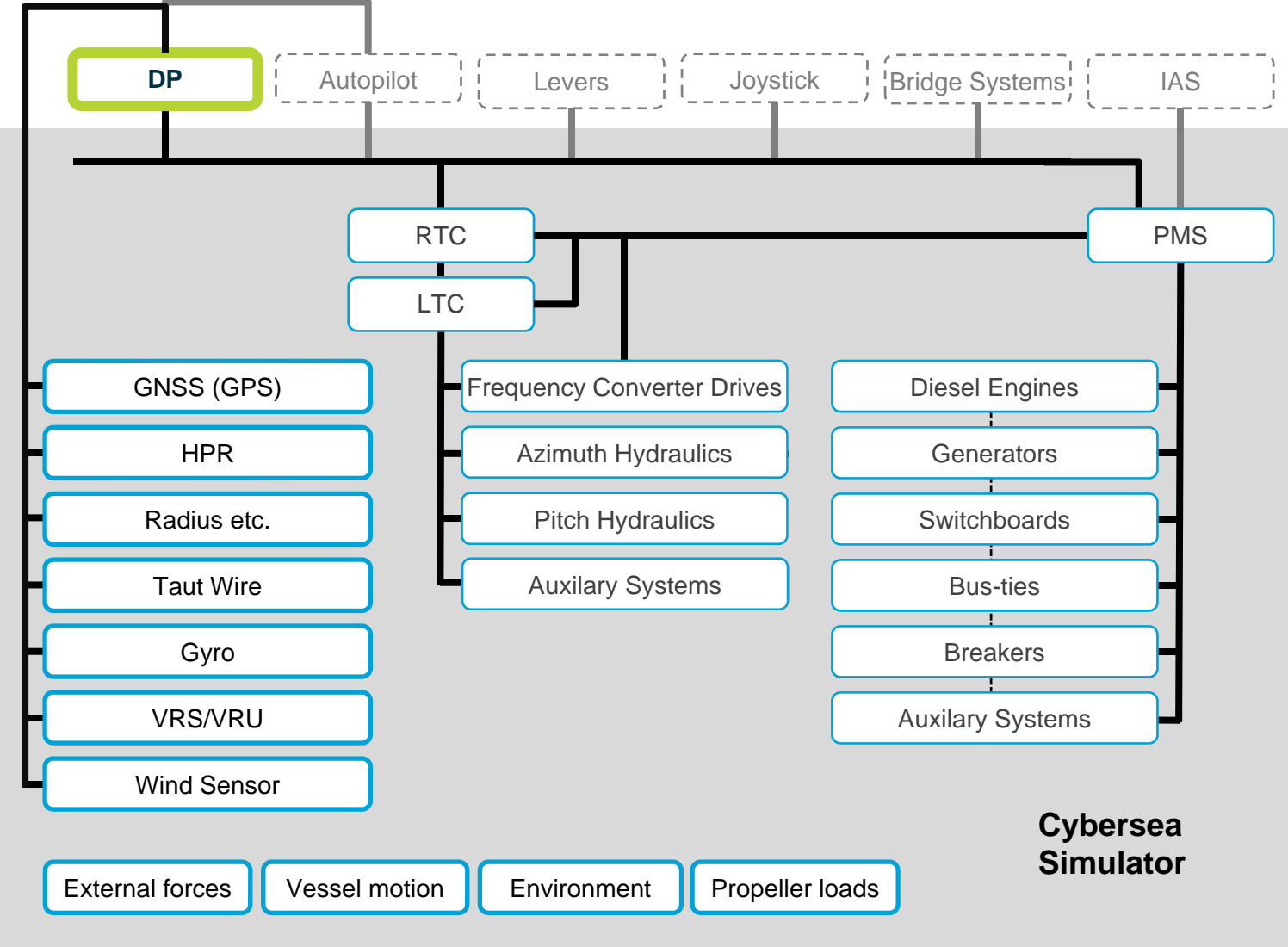

# PMS-HIL testing

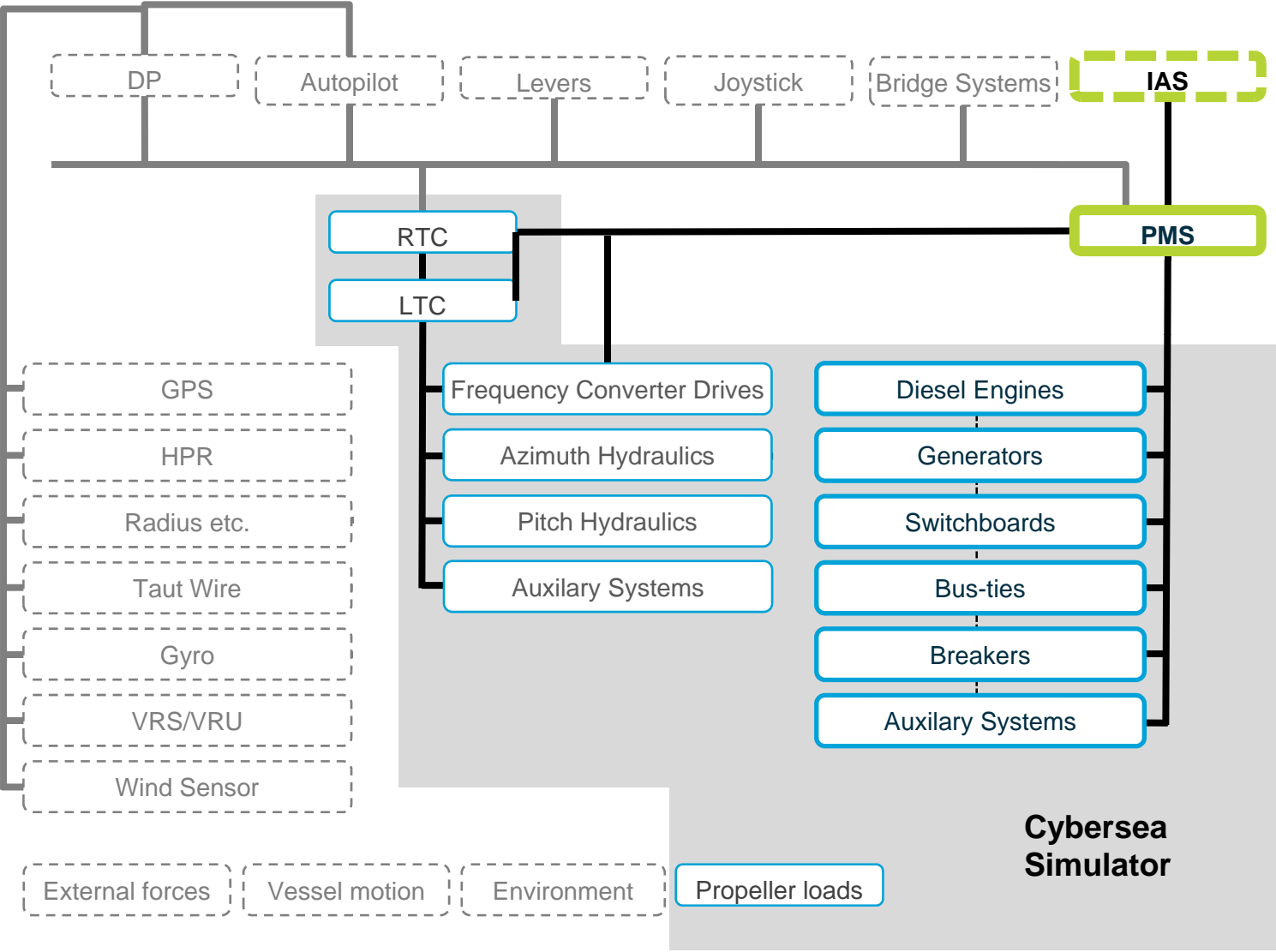

# SPT-HIL testing

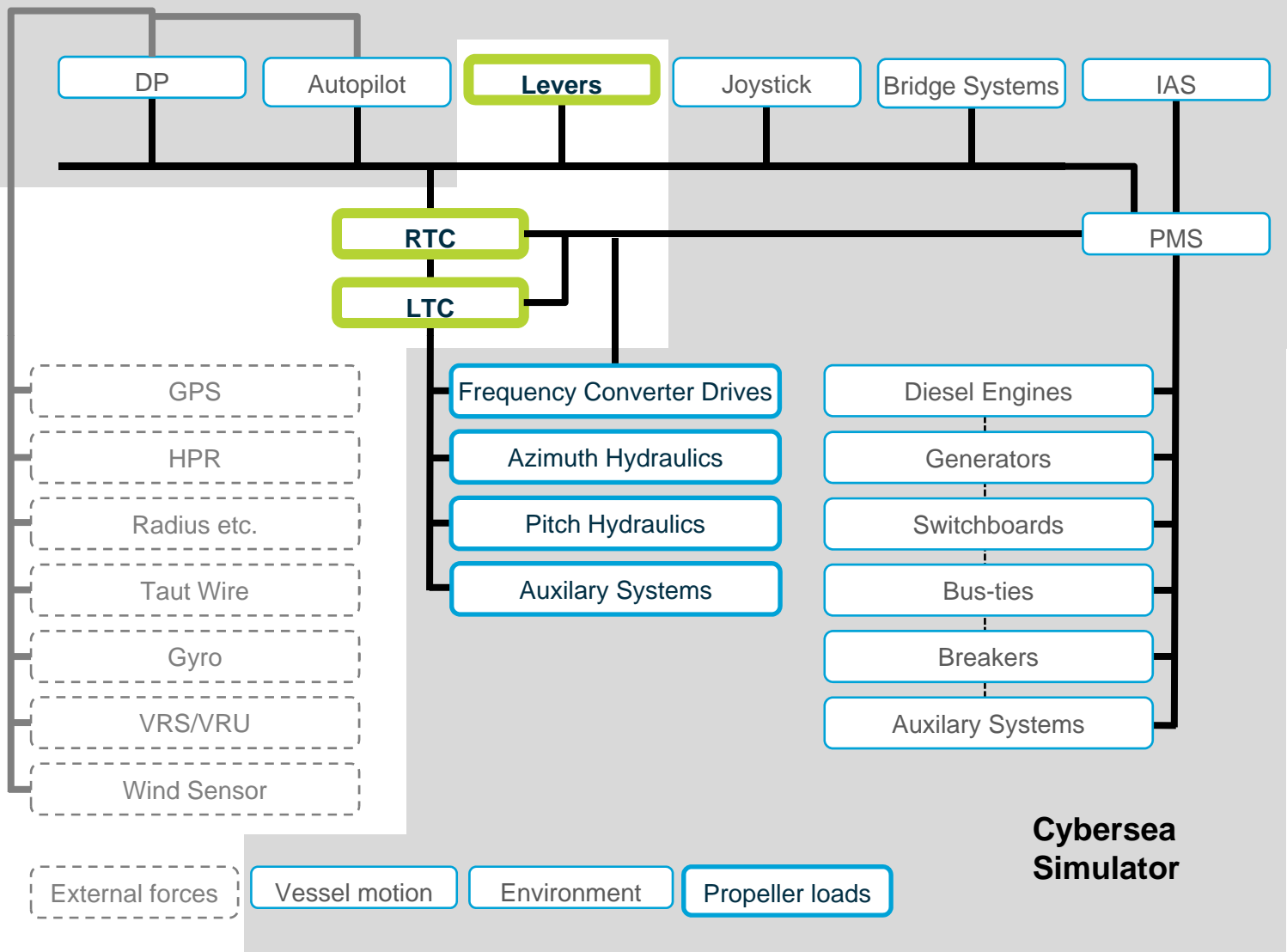

# Integration testing

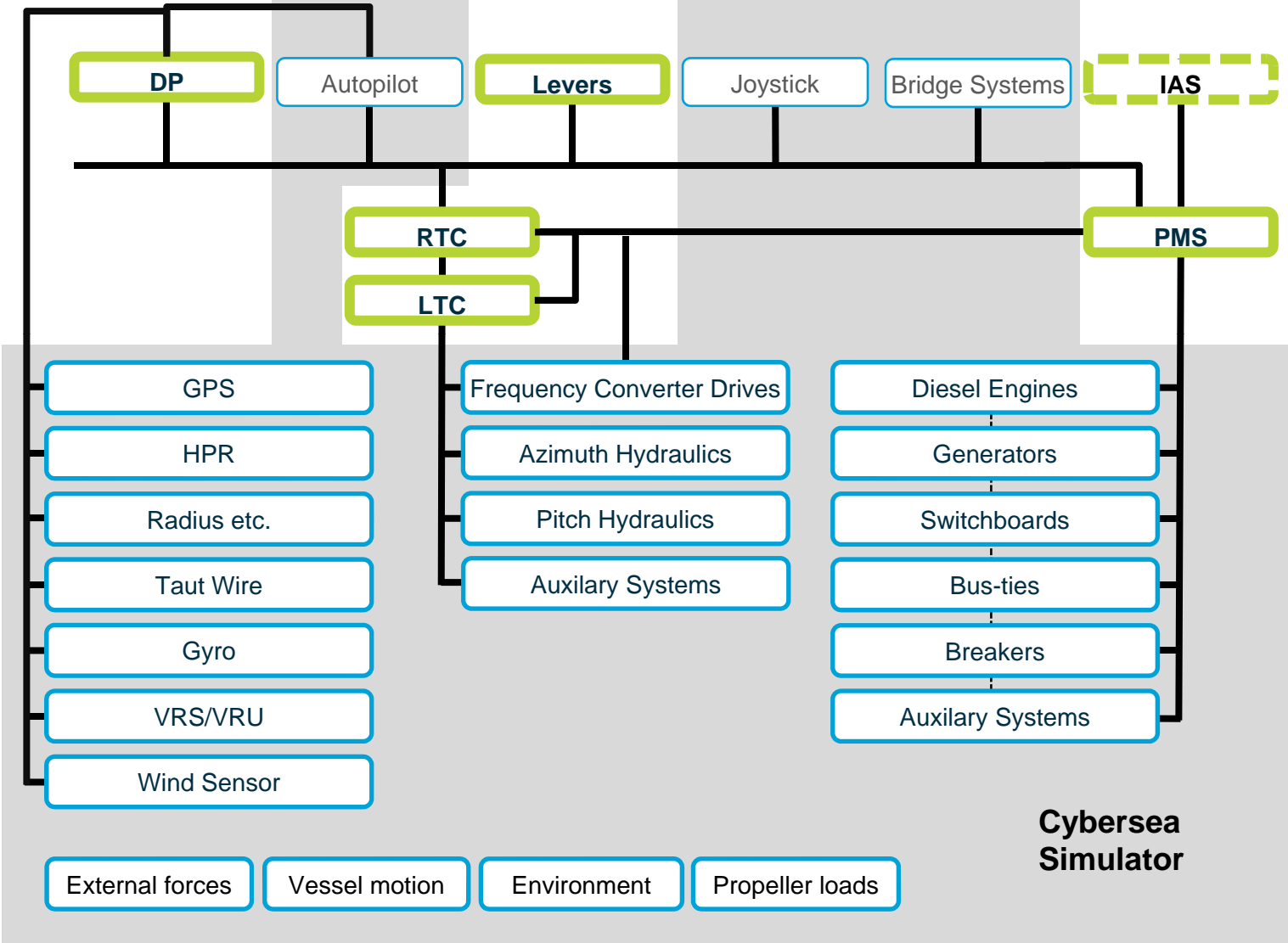

# Experiences from DP system SW testing

By July 2010:

- 60 DP-HIL and 23 PMS-HIL projects fully or partly completed.
- 426 A-findings and 1166 B findings

Finding severity grades:

Severity grade	Definition
A	Non-conformity with rules and regulations (IMO, flag state, coastal state, class rules, and similar)
B	Non-conformity with requirements (specifications, industry guidelines and standards, documentation such as functional design specifications and user manuals, or intended use)

Two important steps taken in the analysis of findings:

- Division of DP computer system and PMS in a set of main functions
- Definition of potential consequences and associated weighting factors

# Definition of potential consequences

*The potential consequence is the worst case consequence if the target system failure associated with a finding should occur during operation*

Potential consequence	Weighting factor	Typical severity grade	Consequence group for plots
Drive-off	10	A or B	Drive- / drift-off
Drift-off	5	A or B	
Other deviations from rules and regulations	2	A	Dev. rules & regulations
Operational unavailability	1	B	Operational unavailability
Degraded system performance	0.5	B	Less serious
Deviation from specification	0.2	B	

# Total DP- and PMS-HIL findings

Distribution on potential consequences

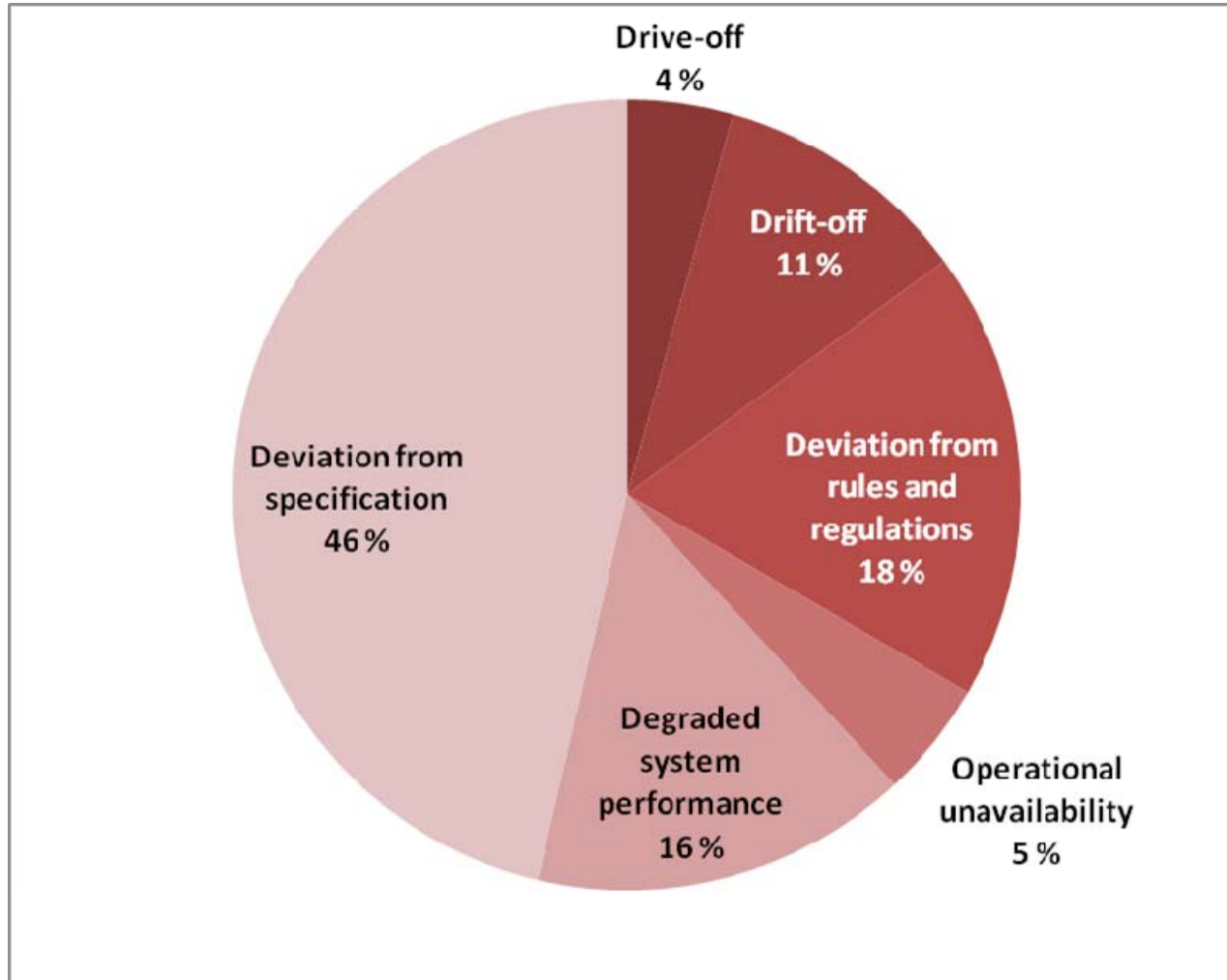

# DP-HIL findings

categorized by functionality and potential consequence

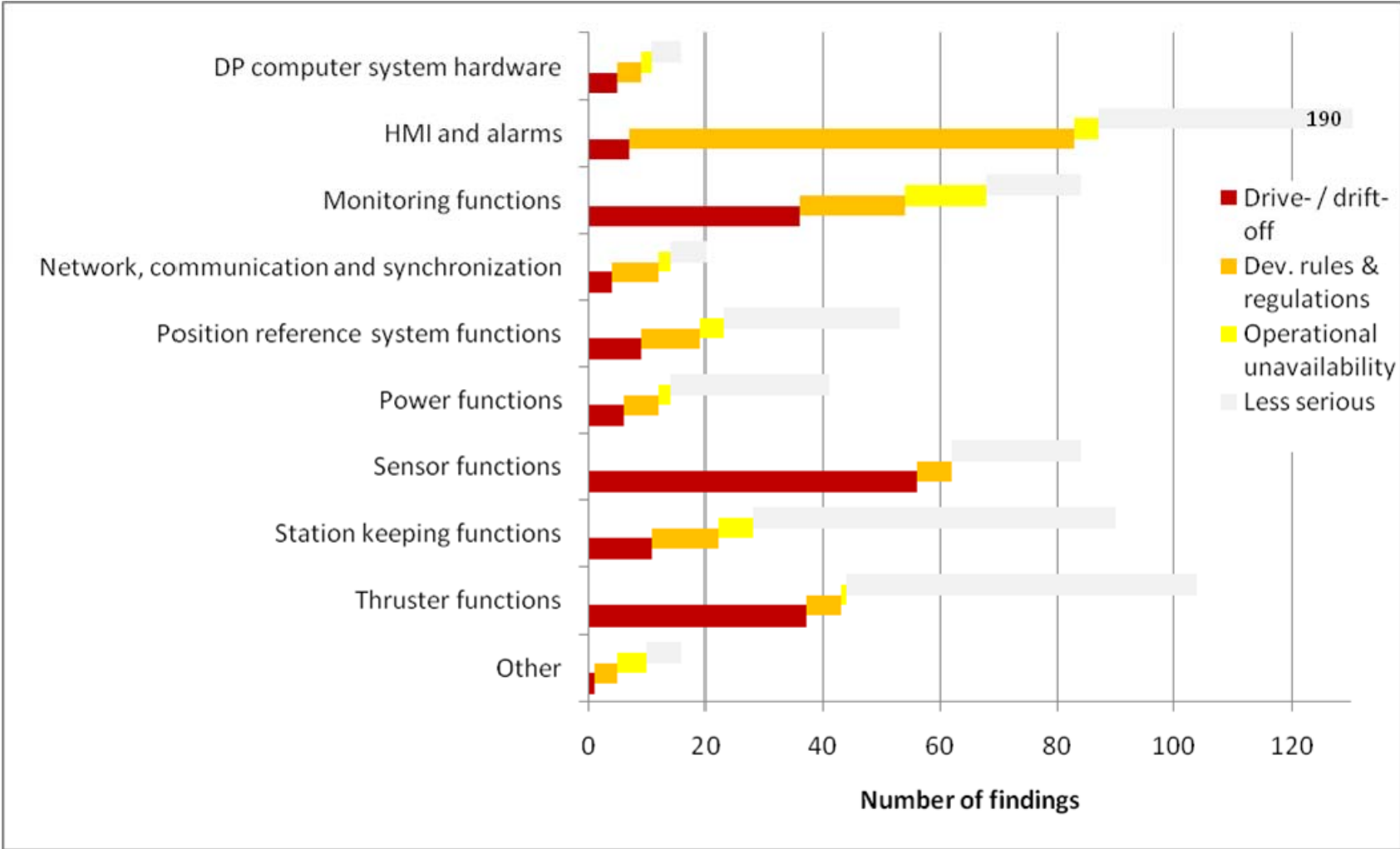

# DP-HIL findings

weighted consequence for the different DP computer system functions

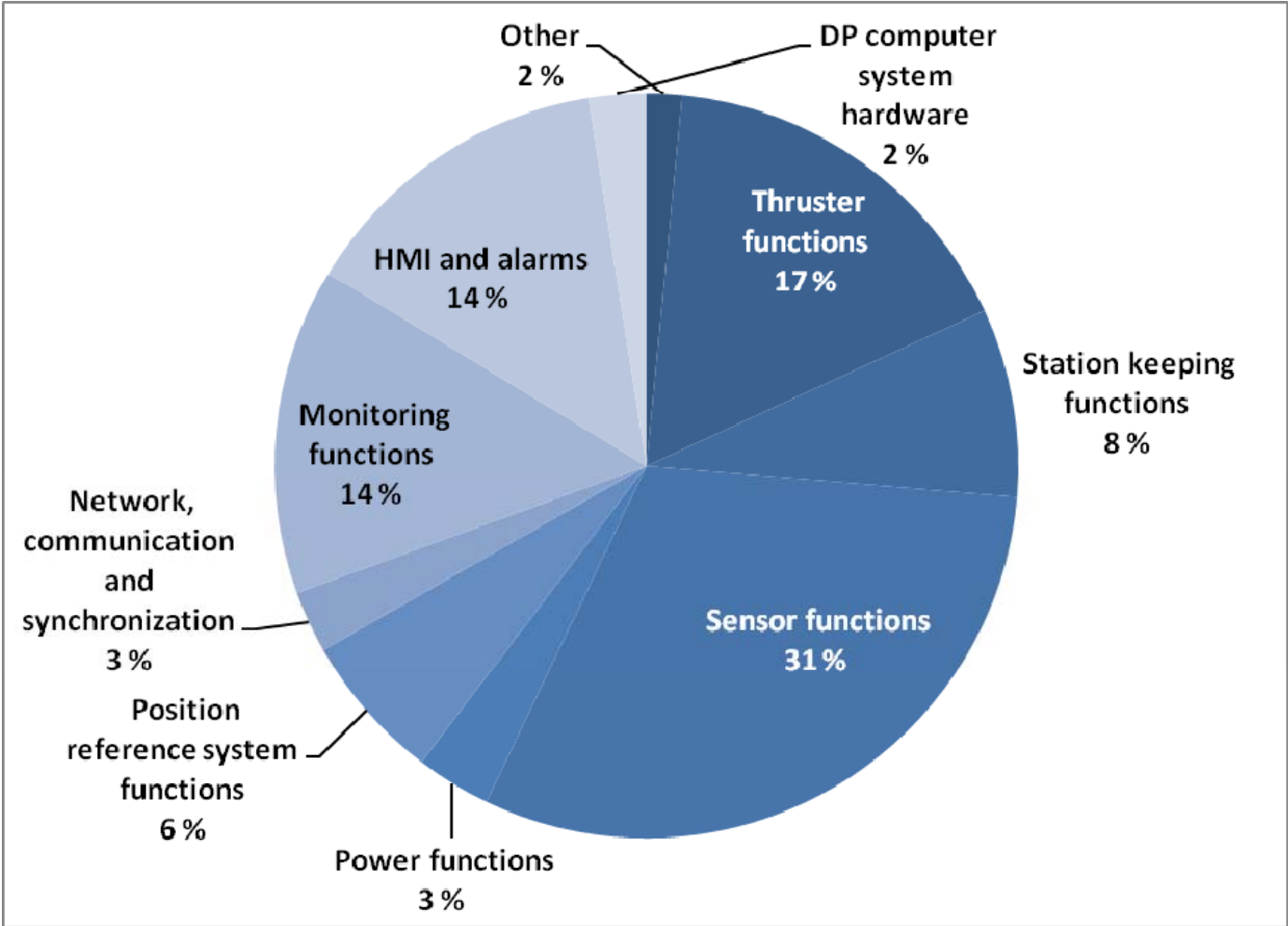

# PMS-HIL findings

categorized by functionality and potential consequence

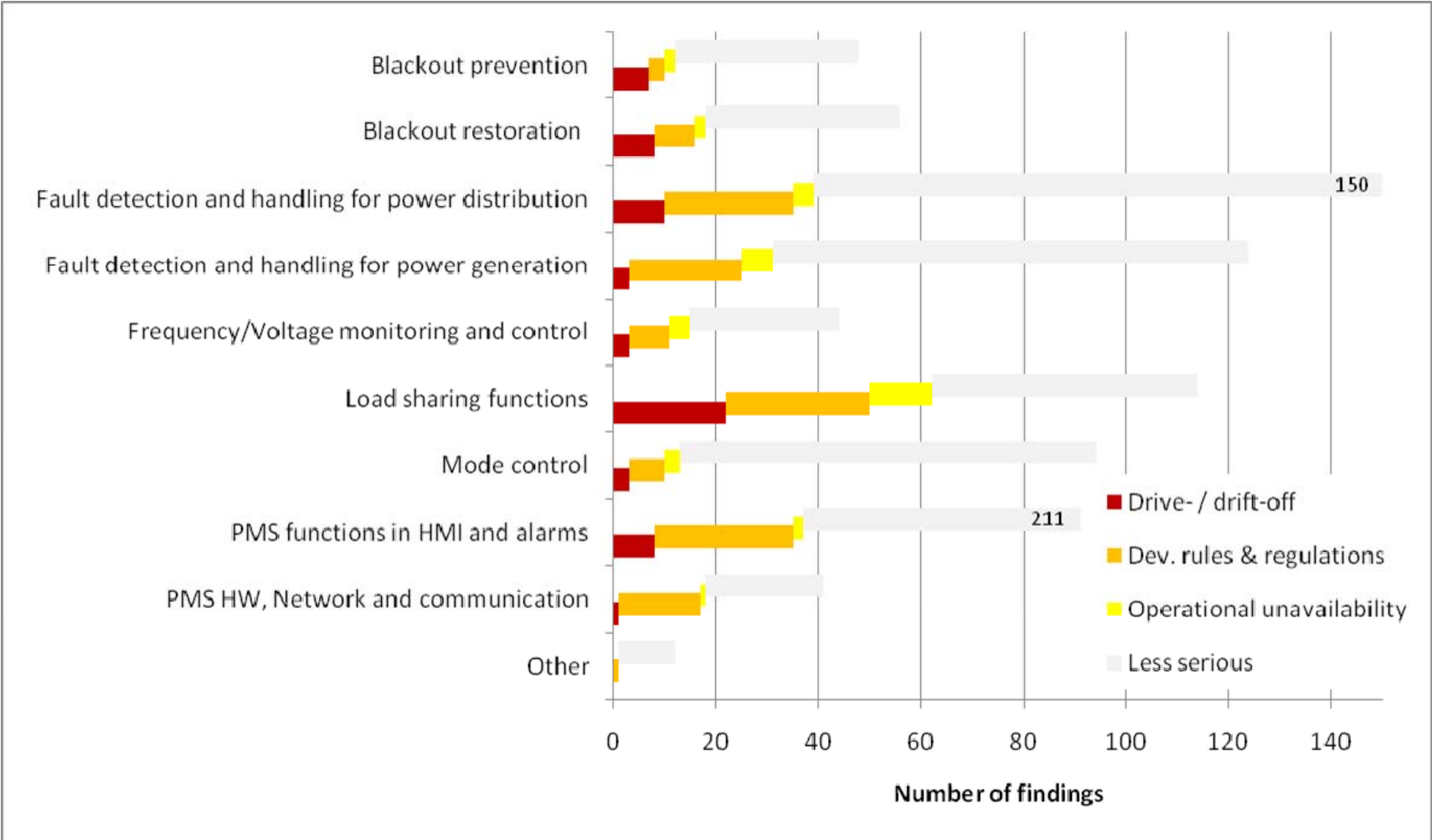

# PMS-HIL findings

weighted consequence for the different PMS functions

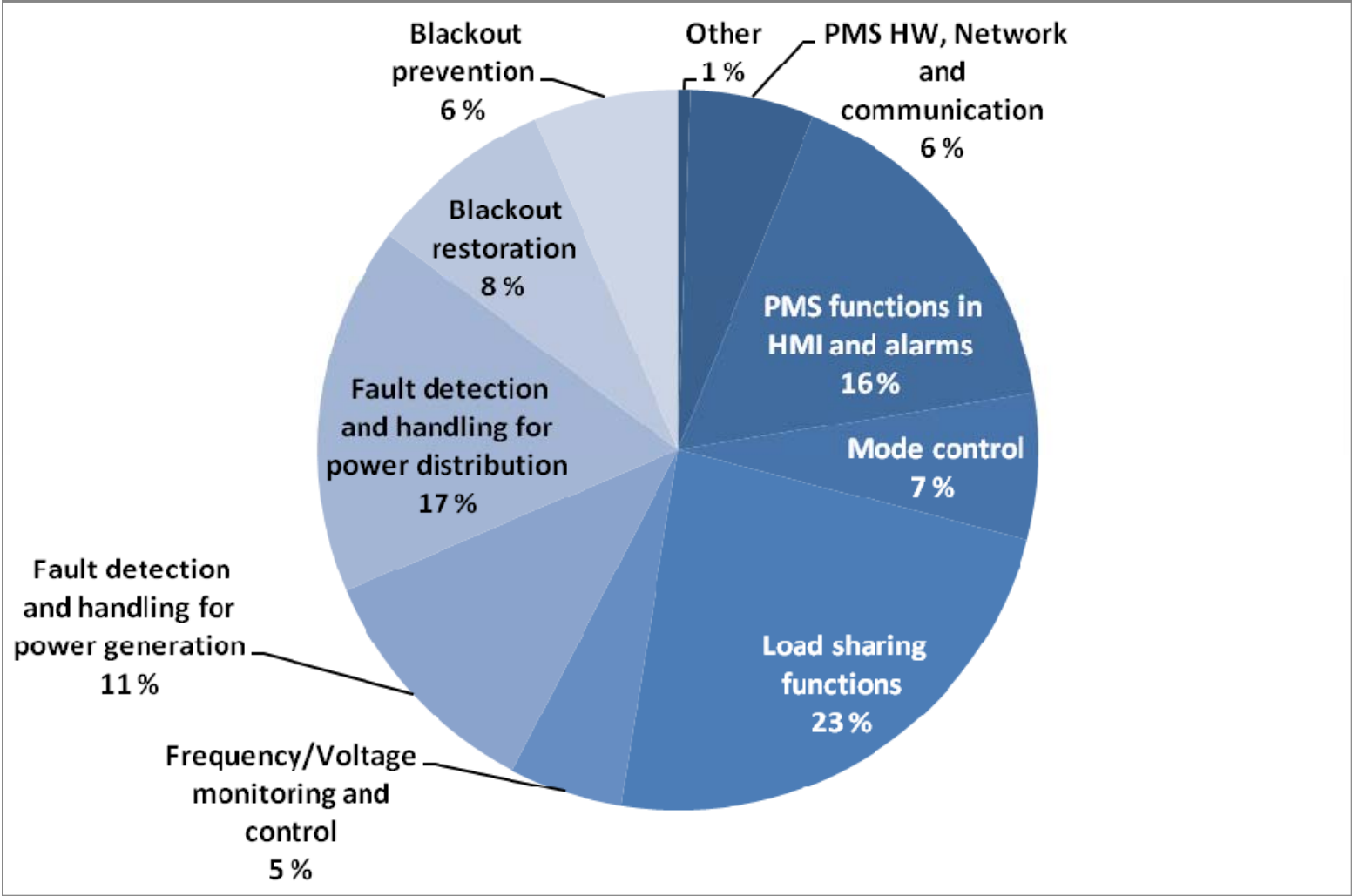

# Example findings

- The main propulsion system enforces restricted zones on both main azimuths, even if one is disabled or shut down. Consequence: the vessel has almost no sideways force in one direction after the failure of a single thruster, rendering the vessel useless for DP class 2 or 3 operation.
- The DP fails to release the restricted zone of a main azimuth thruster if the other main azimuth is only deselected in DP. If the other main azimuth is stopped or taken into local control, the restricted zone is released. Consequence: Even if no consequence analysis alarm is given, the vessel cannot maintain position in DP if a main azimuth is deselected on the DP panel, meaning that the vessel cannot operate correctly in DP class 2.
- A power reserved signal from the PMS is not properly accounted for in the DP. Consequence: Possible partial blackout if one or more generators are in local mode.

# Example findings

- A 4-20mA signal for available power on the bus was used for load limitation of the thrusters. The PMS set 2mA as the available power whenever the power available calculation failed, this was interpreted as zero available power by the thruster control system. Consequence: Full load reduction to all thrusters every time an available power calculation failed.
- Added load on the bus was not accounted for by the DP load limitation. Consequence: The DP will command too much power and thereby force the PMS to start load shedding, with a following loss of position.

# Summary

- The complexity of a modern DP system and the concept of HIL testing were presented.
- Detailed finding statistics for 60 DP-HIL and 23 PMS-HIL projects was presented, showing that potentially serious errors are found in all parts of the DP computer system and PMS.
- Examples of findings focusing on integration issues were presented to illustrate how independent HIL testing helps to facilitate common understanding of the complete DP system at an early stage.

*Thank you for your attention!*

# Experiences from five years of DP software testing

Contact info:

Øyvind Smogeli  
ons@marinecyb.com  
+47 900 88 750

Vestre Rosten 77  
NO-7075 Tiller, Norway  
[www.marinocybernetics.com](http://www.marinocybernetics.com)