



DYNAMIC POSITIONING CONFERENCE
October 12-13, 2010

QUALITY ASSURANCE SESSION

New initiatives related to classification of DP systems

By Aleks Karlsen and Stian Ruud

DNV, Det Norske Veritas AS, Norway

Abstract:***Background***

Since the development of the first DP systems and vessels in the 1960's there have been large developments in the technology, and in parallel also the regulatory framework and classification rules have been developed. This paper describes some new initiatives from DNV related to DP classification and verification.

New IMO MSC/Circ. 645 corresponding DP notations

The DYNPOS-notations have proven to set appropriate requirements in some segments, e.g. harsh environment. However, DNV also experience that in some markets and operational segments, a less stringent standard can be technically acceptable. As a response to market requests, DNV has developed new additional DPS notations customized to markets where the existing DYNPOS notations are considered to be beyond the actual need, e.g. operation in benign waters. The DYNPOS notations are maintained unchanged.

New flexible and redundant DYNPOS-ER notation

The traditional industry practice for redundant dynamic position systems (e.g. the DNV DYNPOS notations and IMO MSC/Circ. 645 "Guidelines for vessels with dynamic positioning systems") is typically based on an approach where the redundancy is based on running machinery, thus not utilizing stand-by units or change over mechanisms. The DYNPOS-ER class notation is not directly related to the IMO MSC/Circ. 645 equipment classes. The notation is based on a somewhat different approach with the intention to exploit the latest technology within power generation, power distribution, thruster technology and advanced integrated control systems in order to allow for flexible and efficient operation of the power and thruster plant.

Enhanced System Verification

The "Enhanced System Verification" rules establish the framework for requirements to earlier, deeper, and broader testing by use of various verification methods. Application of this voluntarily notation gives the users verification additional to the minimum requirements. So far the generic requirements are specifying requirements for the Enhanced System Verification by use of HIL testing. The ESV rules refer to functional requirements established in other rule chapters like DYNPOS (dynamic positioning) and POSMOOR (thruster assisted mooring).

New DNV guideline for FMEA

DNV requires FMEA (Failure Mode and Effect Analysis) and FMEA testing for redundant ship system class notations like e.g. the redundant DYNPOS notations. As per today a lot of the FMEAs received by DNV (especially from FMEA suppliers which are new in these markets) are considered to be weak on items like: documentation of the redundancy design intent, separation, single failure identification, and analysis. As a response to this, DNV has arranged workshops with several major equipment suppliers and FMEA suppliers during 2008-2010 in order to propose a new guideline for FMEA of redundant systems. The aim is to provide a standard by the end of 2010 which can help to improve the overall quality of FMEAs of redundant ship systems.

Background and DP class development 1975-2010

Development of the DNV DYNPOS notations for dynamic positioning systems started as an internal project in 1975. This project led to the first DYNPOS rules being issued in 1977. Since then there has been a constant development of the rules leading up to today's standard.

In the same time as the rules have evolved, DNV has experienced a huge increase in the number of DP vessels being built. The first 20 years DP was typically for specialized vessels, keeping the total number of vessels quite low. The latest 10 years this development has changed radically and DP has become standard for a number of vessel types. This development is still going on and DNV is expecting the share of vessels with DP notations to increase also in the future. Today approximately 18% of the DNV fleet has a DP notation.

The use of DP has also spread into new markets and DNV is experiencing that the different markets are interpreting the DP system industry standards differently. This applies typically to IMO MSC/Circ.645 "Guidelines for vessels with dynamic positioning systems" (1994). One result of the different interpretations is e.g. that different markets and/or major operators' sets different requirements to design of a standard DP-class 2 vessel.

Some of the trends in the use of dynamic positioning evolving from the last part of 1990's have been:

- rapid increase of DP fleet
- increased use of DP vessels into new markets and for more operations and vessel types
- operation under different environmental conditions (winterized harsh vs benign temperate climate)
- high variations of operational risk
- more owners, equipment suppliers, consultants,...

Above trends have led to diversified market needs and different interpretations of e.g. the existing IMO MSC/Circ.645 standard.

The DYNPOS-notations have proven to set appropriate requirements in some segments, e.g. harsh environment. However, we also experience that in some markets and operational segments, a less stringent standard can be technically acceptable.

As a response to market requests, DNV has developed and published new DPS notations (2010) customized to markets where the existing DYNPOS standard is considered to be beyond the actual need, e.g. operation in benign waters. One other result of this diversity in the market is that these less stringent standards may not be accepted in all market segments.

In parallel to the above trends, there have also been huge technology developments since the establishment of the philosophy which the current rules and guidelines are based on. Some segments of the DP industry have taken the new technologies into use and a lot of experiences with different designs have now been collected. However, some of the designs have in some respects been challenging the existing rule practice and philosophies, e.g. open or closed bus-ties on DP-3 systems.

Parts of the motivation for taking new technologies into use in DP systems have been:

- Flexibility: The existing rules offer little flexibility in operation, e.g. for maintenance. By utilizing change-over systems, running with standby generators and closed bus-ties the flexibility of the plants can be significantly increased.
- Availability/Reliability: New technology may be used to limit the effect of failures, e.g.: stand-by start, change-over in order to increase the availability of power and thrust and hence increase the reliability of the position keeping. Advanced protection systems and more autonomous systems may be used in order to minimize the effect of failures.
- Fuel economy: Less spinning reserve, more use of stand-by start and change-over will reduce the fuel consumption during operations. Equipment can run at levels where the power efficiency is at its best.
- Environment: The industry want to operate as environmental friendly as possible and less fuel consumption will contribute to this by lowering the environmental footprint of the dynamically positioned units.

In order to take benefit of the new technologies and support the above motivations, DNV has in 2010 published new rules for a notation for redundant dynamic positioning systems. The notation is denoted DYNPOS-ER. This notation has no direct relation to the IMO MSC/Circ.645 and should not be classified in terms of IMO equipment classes.

Parts of the above mentioned technology developments in marine control systems and machinery installations have led to radically changes from traditional mechanical machinery to modern integrated machinery and control systems. This includes complex configurations of diesel and electric machinery.

One of the challenges following the technological, operational, and market developments, are the needs for additional test and verification methods beyond the minimum verification requirements. As a response to these requests, DNV has developed a notation called Enhanced System Verification (ESV). The overall intention with this notation is to establish rules for a set of different verification methods, which can be applied to specific systems. As a starting point the first rule edition set requirements for Hardware-in-the-Loop testing of control systems for dynamic positioning and position mooring.

In the future we envision that the ESV rules will be extended with new sections with requirements to both new systems and other verification methods. One possible option for a new ESV method is requirements for FMEA.

In the period 2008-2010 DNV has taken an initiative towards some leading DP FMEA consultants and equipment manufacturers with the intention of documenting the existing best practice into a guideline for minimum requirements to 'FMEA of redundant systems'. The background for the initiative is related to the needs for a more structured analytical approach and a clarification of the minimum requirements. One of the identified needs behind this initiative is related to the need for quality improvement in parts of the new evolving markets. The plan is to submit the guideline on a formal external hearing in the beginning of 2011.

New DPS notations

Approach

The new DNV rules for Dynamic Positioning Systems Pt.6 Ch.7 detail the notations in two different notation series, being the **DPS-** series and the **DYNPOS-** series of class notations. The below table lists the notations and indicates how these relates to the IMO equipment classes as they are defined in IMO MSC/Circ.645 “Guidelines for vessels with dynamic positioning systems”:

<i>IMO equipment class</i>	<i>DNV class notations</i>	<i>Additional information</i>
Not applicable	DPS 0	New notation. No redundancy requirements.
	DYNPOS-AUTS	No redundancy requirements. Additional requirements to achieve higher availability and robustness as compared to DPS 0.
IMO equipment class 1 (No redundancy)	DPS 1	New notation. No redundancy requirements.
	DYNPOS-AUT	Additional requirements to achieve higher availability and robustness as compared to DPS 1. No redundancy requirements.
IMO equipment class 2 (Redundancy in technical design)	DPS 2	New notation. Redundancy in technical design is required.
	DYNPOS-AUTR	Redundancy in technical design is required. Additional requirements to achieve higher availability and robustness as compared to DPS 2.
IMO equipment class 3 (Redundancy in technical design and physical separation of systems)	DPS 3	New notation. Redundancy in technical design and physical separation of systems is required.
	DYNPOS-AUTRO	Redundancy in technical design and physical separation of systems is required. Additional requirements to achieve higher availability and robustness as compared to DPS 3.

The requirements for the DYNPOS-series of notations are unchanged and hence the introduction of the DPS notations offers more alternatives to the vessel owners in order to tailor the vessel notation for the intended market segments.

Major differences between DPS- series and the DYNPOS- series

Even though both notations corresponds to the IMO equipment classes there are distinct differences between the two DP notation series. The main differences are discussed below.

Thruster configuration

For typical industry “DP-0” and DP-1 designs there are distinct differences in the requirements to the thruster configuration for DPS 0 and DPS 1 as compared to corresponding DYNPOS notations. The DYNPOS-AUT(S) notations require that there shall be minimum one thruster (tunnel or azimuth) in the stern of the vessel. The non-redundant DPS-notations (DPS 0, DPS 1) may accept that transverse thrust in the stern is based on the combined use of pitch propellers and rudders in a traditional twin propulsion system.

For typical industry DP-2 designs a very common design (which is not accepted in its simplest form (two-split) by DYNPOS-AUTR) consist of a thruster configuration of: 2 main pitch propellers with separate rudders, 2 bow tunnel thrusters and a single stern tunnel thruster. The thrusters are typically driven by shaft generators and the redundancy is normally based on two

redundancy groups where the single stern tunnel thruster can be changed over between the two redundancy groups based on simple break-before-make switching. This standard industry DP-2 thruster configuration is accepted by the DPS 2 notation

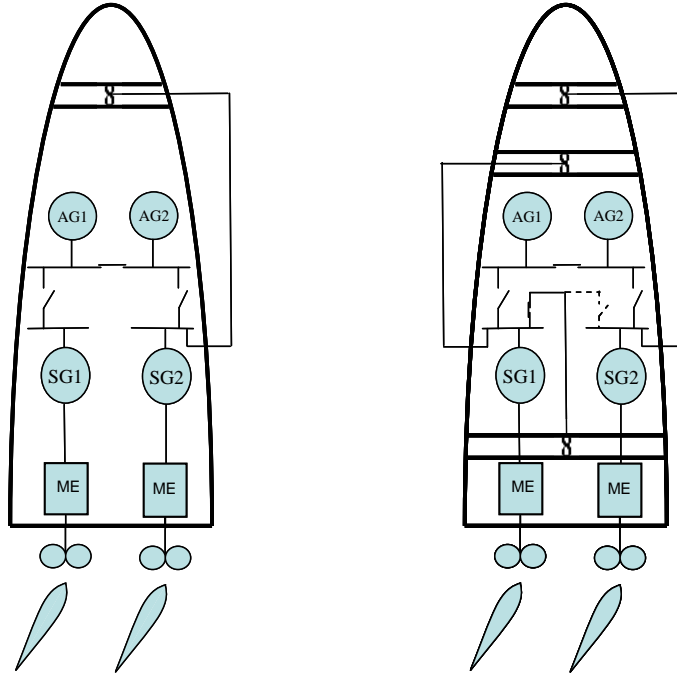

Fig.1. The thruster configuration indicated at the left figure will be acceptable for DPS 0 and DPS 1, but will not be acceptable for DYNPOS-AUTS and DYNPOS-AUT. The thruster configuration indicated at the right figure will be acceptable for DPS 2, but will not be acceptable for DYNPOS-AUTR

For typical industry DP-3 designs the redundancy requirements will basically be the same for DPS 3 and DYNPOS-AUTRO due to the physical fire and flooding separation.

Auxiliary systems

For auxiliary systems, there are differences in the requirements between DPS 2 and DYNPOS-AUTR.

Over the years the requirements to auxiliary systems for the redundant DYNPOS-AUTR notation have been strengthened and today separate systems are required for each redundancy groups for fresh water cooling systems, fuel oil systems and pneumatic systems.

Requirements for DPS 2 are based on IMO MSC/Circ.645 “Guidelines for vessels with dynamic positioning systems” and static components like coolers, filters and piping/tanks may be considered as not failing. Hence, common static components may be accepted also in fuel oil systems, fresh water cooling systems and pneumatic systems.

Reference is made to IMO MSC/Circ.645 “Guidelines for vessels with dynamic positioning systems”:

‘Part 2.2.2 For equipment class 2, a loss of position is not to occur in the event of a single fault in any active component or system. Normally static components will not be considered to fail where adequate protection from damage is demonstrated, and reliability is to the satisfaction of the Administration. Single failure criteria include:

- .1 Any active component or system (generators, thrusters, switchboards, remote controlled valves, etc.).*
- .2 Any normally static component (cables, pipes, manual valves, etc.) which is not properly documented with respect to protection and reliability.’*

Other differences

There are also a number of other differences between the notation-series. Two examples are listed below:

- No dedicated PMS system is required for the DPS 2 and DPS 3
- ERN is not required for the DPS-notations

To get a full overview of the differences please refer to the rules, where Pt.6 Ch.7 Sec.2 Table C2 summarizes the most important differences.

Class entries from other classification societies to DNV

Class entry to the DYNPOS- series will require verification towards the relevant requirements for the given notation and shall be based on documentation review, performance testing and FMEA failure testing as required for the individual notation. This means that any possible deviation towards the DNV requirement will need to be rectified before the notation is granted.

Class entry to the DPS- series system design will be accepted based on a corresponding, valid and maintained Dynamic Positioning class notation, from the losing society. Hence no additional verification will be required before the DPS notation is granted.

Link to the DNV rules for Dynamic Positioning Systems:

<http://exchange.dnv.com/publishing/RulesShip/2010-07/ts607.pdf>

New DYNPOS-ER notation

Approach

The approach has been to base the development on new principles and philosophies which make it possible to further utilize the latest technology within power generation, power distribution, thruster technology, and advanced integrated control systems.

The intention is to achieve a resulting integrity towards loss of position and heading which is comparable to or exceeding IMO equipment class 2 and equipment class 3 (depending on which failure mode being evaluated).

The notation target specific failure modes which are considered/experienced to be more frequent in modern vessels. One example of this is that the requirement to separation in current equipment class 3 notations is by some considered excessive when looking at the incident statistics.

About the DYNPOS-ER notation

The new DNV DYNPOS-ER (Enhanced Reliability) notation provides a new set of rules for a flexible and redundant DP system design.

This notation is a new optional notation additional to the existing notations for dynamic positioning systems. It has no direct relation to the IMO MSC/Circ.645 and should not be classified in terms of IMO equipment classes. The notation is not directly comparable with the existing standards for dynamic positioning system.

One of the basic principles for the notation is to allow for connected power systems. On specific conditions it is also the intention to utilize standby start and change-over of generators and thrusters as basis for redundancy. This supports the intended goals of achieving systems which:

- are flexible and efficient in operation
- are economic and have lower environmental footprints
- have high availability of power and thrust
- have less consequence of failures as compared to standard DP notations

Specific requirements are given with the intention of ensuring high integrity and availability of electrical power plants. When electrical generators are running in parallel the notation requires an advanced protection system for failure detection and discrimination of failed components before a full or partial black-out situation occurs. Examples of failures to be considered are:

- governor failure
- AVR failure
- under voltage e.g. as a consequence of short circuit (, and system “ride through” capability)
- overvoltage, including transients
- short circuits and over-current
- earth failures
- negative sequence-high harmonic distortion (THD)
- failures related to load sharing (active and reactive load, reverse power, communication, I/O...)
- failures in the power management system

In addition to the above, the rules further requires that in case the protection system is not able to isolate the failure by tripping of a failed component, it shall open bus-tie breakers to separate the redundant switchboard sections before the failure effect can propagate from one system to another.

As opposite to most existing DP standards DYNPOS-ER sets requirements for fast black-out recovery on individual switch-board sections by starting of generators and recovery of full automatic thruster control from DP. The intention is to restore power and thrust within separated systems as fast as possible in case of a failure.

The DYNPOS-ER notation is not only taking advanced systems in use. When it comes to arrangement of systems more autonomous generators and thrusters systems are required. This limits the effect of certain failures within these systems and implies simplification of the system on this level.

Equal to the existing standards for redundant DP systems the DYNPOS-ER rules set requirements to redundancy and duplication of equipment. However, by allowing for change-over and standby start the total number and/or size of generators and thrusters may be reduced, since the parts of the required capacity after failure may be based upon such functionality. There are however some limitations on to the use of change-over and standby start, and the most important of these are:

- After a failure maximum 50% of the remaining thruster power can be based on change-over arrangement.
- It is assumed that any one of the available stand-by generators may not start. However, standby-start is considered neither failing simultaneous with a short circuit of a main bus-bar with where special precautions are taken to minimize the risk of a short circuit nor simultaneous with a fire in a different redundancy zone.

The DYNPOS-ER notation also set requirements to physical fire and flooding separation of the defined redundancy groups. The separation requirements are somewhat lower than traditional DP-3 requirements. Fire and flooding separation requirements may be summed up in short as:

- A-0 class fire division between the redundancy groups as minimum, and in addition
- A-60 class division is required in high fire risk areas
- watertight bulkheads if located below the damage water line
- No separate DP back-up room as for DP-3 systems is required. Independent joystick in the traditional main station will be replaced with a single independent alternative DP control system.
- The main controllers for the main DP control system shall neither be located in the DP control centre nor in the same space as the main controller for the alternative DP control system.

Other examples where the DYNPOS rules have more specific and higher requirements as compared to traditional standards are, e.g.:

- Position reference systems and sensors
- Indication, display and monitoring
- Data-logger is required instead of the traditional DP printer
- Capability plots to be carried onboard.

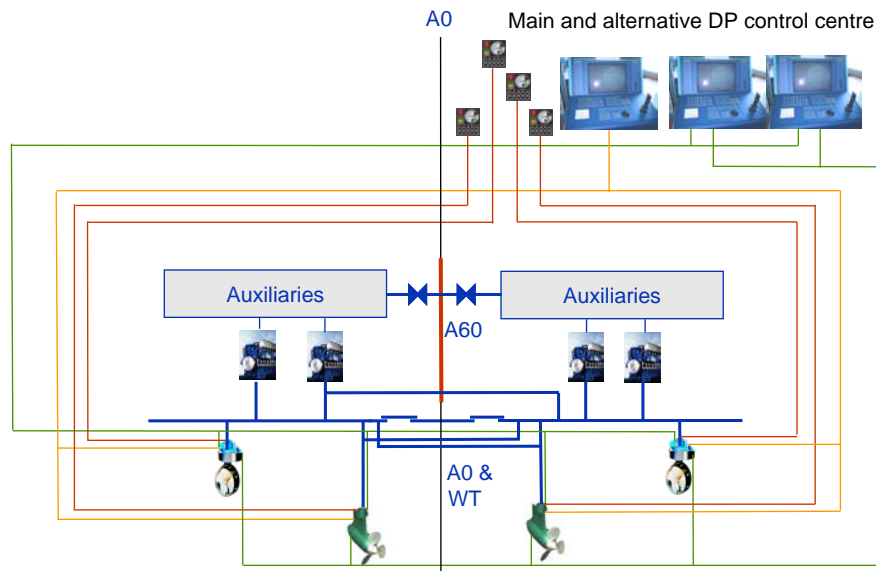

Fig.2. Principle arrangement for DYNPOS-ER notation

The technologies required to build a DYNPOS-ER notation are available today. Some development may be required in order to comply with the requirements, e.g. the notation will require more sophisticated consequence analysis software compared to what is generally found in today's standard DP-control system software.

It is important to notice that the DYNPOS-ER notation is a new additional option, and hence not a direct replacement for DYNPOS-AUTR or DYNPOS-AUTRO as these notations will still be maintained. It is therefore possible to have the DYNPOS-ER notation in combination with e.g. DYNPOS-AUTR if requested.

Challenges

The introduction of a new notation for dynamic positioning systems as described here imposes several challenges for DNV and also for the industry when applying the new notation:

- Acceptance of the new notation by users, operators and authorities are imperative.
- Documentation and verification of the intended integrity in the complex systems required by the notation will be a challenge. Strict requirements to identification and evaluation of possible failure modes will be required in the FMEA. Especially when redundancy is based upon closed bus-ties, discrimination, standby/restart, change-over and on demand functionality in advanced control systems.
- Testability. Verification of the built-in integrity will be demanding. Use of e.g. ESV-DP[HIL] may increase the verification level.

Link to the DNV DYNPOS-ER rules:

<http://exchange.dnv.com/publishing/RulesShip/2010-07/ts626.pdf>

Enhanced System Verification

History

In 2003-2006 DNV participated in a Joint Industry Research Project with major industry partners for developing new test and verification methods for marine control systems. The main motivation was to improve the reliability and safety related to offshore industry vessels control systems.

The first step was achieved in 2005 when DNV prepared a draft Standard for Certification of HIL testing. In June 2006, Acergy Osprey was awarded the first HIL test certificate in compliance with the draft standard. Statoil has developed 'DP Unit requirements' stating that HIL testing should be carried out for specific vessels types.

Above activities were followed up in 2007 when a new Joint Industry Project (JIP) was established for developing a DNV class notation related to Enhanced System Verification. The Enhanced System Verification (ESV) rules and class notations were published in 2010.

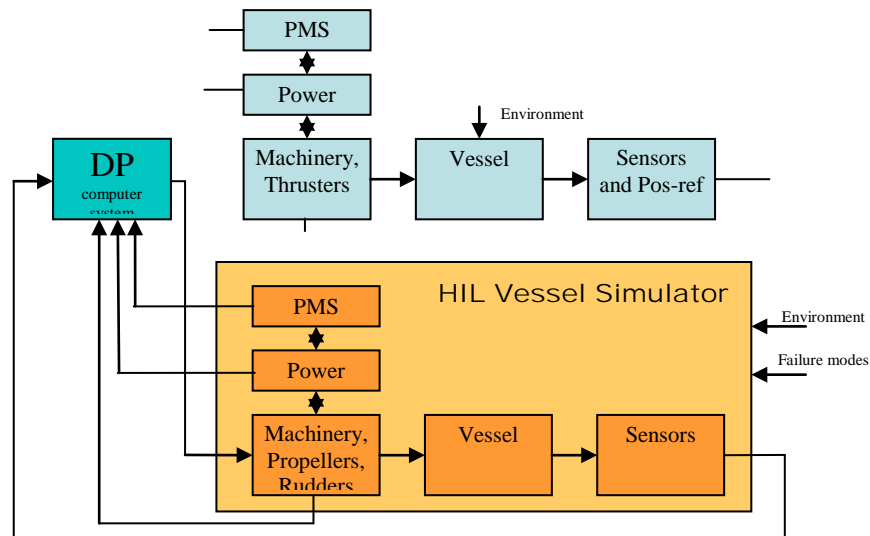

Fig.3. HIL Vessel simulator is typically used at manufacturer works where the simulator represents the vessels systems, the external environment and failure modes are generated and sent to the target DP computer system.

About ESV rules

The Enhanced System Verification rules establishes the framework for requirements to earlier, deeper, and broader testing and verification by use of various verification methods. Application of this voluntarily notation gives the users verification additional to the minimum requirements.

So far the generic requirements are specifying requirements for the Enhanced System Verification by use of HIL testing. The ESV rules refer to functional requirements established in other rule chapters like DYNPOS (Dynamic Positioning) and POSMOOR (thruster assisted mooring). In the first edition the ESV-DP[HIL] (Dynamic Positioning) and ESV-TAM[HIL] (thruster assisted mooring) are available class notations.

The main requirements in the ESV rules for HIL testing are:

- HIL testing shall be carried out at the manufacturers works, and onboard the vessel. The HIL testing shall assure that the target system has been configured, and completed according to relevant functional specifications and requirements.
- All tests shall be according to test programs approved by the Society upfront the HIL test sessions. The Manufacturing Survey test program shall be prepared for testing of the target system at the manufacturer works. The onboard testing test program shall be prepared for testing of the onboard installed target system.
- The company which makes the HIL test packages shall be independent from the other involved parties.
- Ship in Operation (SiO) establishes requirements for annual and complete surveys (5 years). The ship owner will be required to follow up the DP/TAM systems in a more comprehensive manner compared to the standard DP notations.

By 2010, the market request for HIL test certification has led to about 30 HIL test certification contracts for DNV in compliance with the Standard for Certification of HIL testing.

In 2010 the ESV rules were published and the first ESV notation was awarded to the Farstad vessel 'Far Searcher'.

The ESV rules are prepared for inclusion of future target systems (e.g. steering, propulsion, thruster, drilling ...) and additional future verification methods (FMEA, white box testing ...).



2010 (Courtesy Farstad and Marine Cybernetics).

on in July

Reference to new building rules:

<http://exchange.dnv.com/publishing/RulesShip/2010-07/ts622.pdf>

Reference to ship in operation rules:

<http://exchange.dnv.com/publishing/RulesShip/2010-07/ts701.pdf>

Guideline for FMEA of redundant systems

Class notations like DYNPOS-AUTR, DYNPOS-AUTRO, DPS 2, DPS 3, DYNPOS-ER, RP, RPS, AP-2, AP-3 requires redundancy. An FMEA of the system redundancy is required to prove the specific acceptance criterion for the specific notation. The requirements of the new guideline for FMEA of redundant systems are foreseen to apply to failure mode and effect analysis (FMEA) for class notations stated above.

The intentions for DNV of developing the Guideline for FMEA of redundant systems were related to:

- establish a minimum set of requirements for FMEA's suited for above stated class notations
- contribute to clarification of the requirements and clarify the minimum quality of FMEA's also for consultants less experienced with such notations
- require a more structured documentation approach, which will provide an improved basis for the analysts in the process of identifying possible complex failure modes and failure propagation paths
- challenge the analysts to cover also the intricate areas of the systems, e.g. closed bus-ties and complex control systems like PMS
- supporting the development of new notations like DYNPOS-ER
- development of possible future extension of the ESV rule chapters

The objective of failure mode and effects analysis of redundant systems is to provide objective evidence of acceptable redundancy and fault tolerance for stated system operational modes. The FMEA documentation shall be self contained and provide sufficient information to get the necessary overview of the system.

A failure mode and effect analysis (FMEA) of redundant systems shall as a minimum consist of the following parts:

- general vessel information
- acceptance criteria,
- the overall system boundary of the unit to be subject for FMEA
- redundancy design intent(s) and operational modes
- all redundant components and single component groups included within the overall system boundary. The relevant system names, main units, compartments (when applicable), and their main intended functions shall be presented in a structured manner, supported with a descriptive narrative text.
- all assumptions related to systems interfaces and dependencies of external systems
- single failure analysis at unit and subsystem levels
- if applicable, description of the installation of redundant component groups in fire and flooding protected compartments. This also includes cables and communication lines, and associated equipment.
- A reference to a test program to support the conclusions shall be included or referred
- A compliance statement referring to the overall system boundary, operational modes, tests, and acceptance criterion shall be stated for the FMEA.

In order to illustrate the main requirements in the guideline, some examples from the document are shown in the next pages: Below is shown an example with 4 thrusters and 4 diesel generators for a DYNPOS-AUTR notation

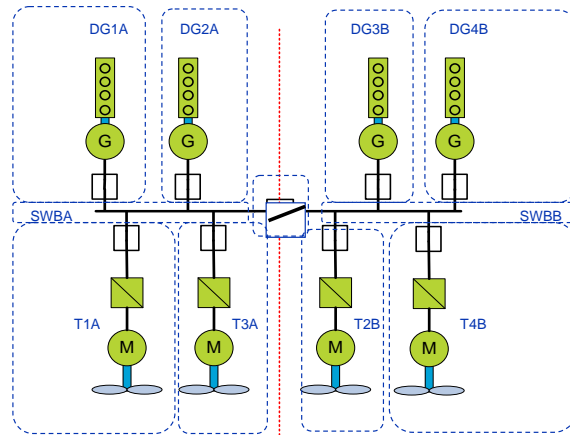

Fig.5. The redundancy design intention in this example may be described in an e.g. narrative way by describing both the normal operation mode and the failed operation mode.

Redundancy design intention:		Redundancy type/description
The normal operation before failure, ->	shall be based on positioning of the T1A and T3A thruster group and the T2B and T4B thruster group	Active redundancy
In the case of a single failure, ->	the positioning operation shall be based either on the (T1A and T3A) thruster group or the (T2B and T4B) thruster group. A single failure shall not give loss of positioning by a drive off by any thruster T1A, T3A, T2B, T4B.	Active redundancy

Single failure propagation in redundant systems

The main issue with regard to failures in redundant systems is to clarify that no single failure or no single failure cause may affect the redundant systems as defined in the redundancy design intention. There are basically three effects that may lead to non-acceptable simultaneous failures of redundant systems.

1. Failure in a component group or subsystem which both redundant systems are dependent on or both systems have common components, so that a failure will affect both redundant systems (e.g. common cooling system)
2. Common cause failure affecting both redundant systems (e.g. fire flooding, external EMC, GPS satellites, extreme movements of vessel,)
3. Primary failure in one of the redundant systems propagating to the other redundant systems (e.g. short circuit,)

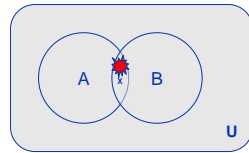

Fig.6. Common component X causing failures in A and B

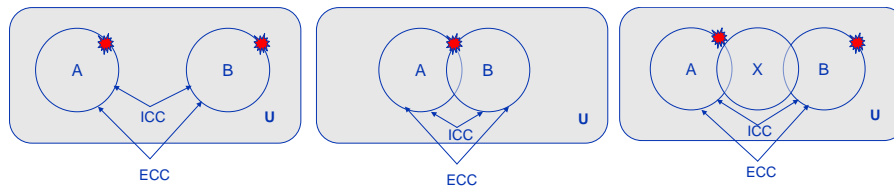

Fig.7. Common cause failure, resulting from a single event related to U, e.g. either as an external (ECC) or an (ICC) internal common cause. (E.g. fire and flooding, environment, vibration, high seas affecting contamination in fuel tanks, shocks, humidity, EMC,....)

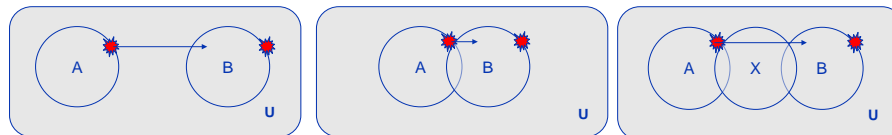

Fig.8. Primary and secondary failure

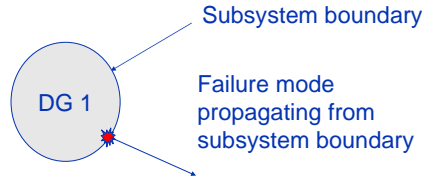

Fig.9. Subsystem boundary for a diesel generator (DG 1). A failure mode is the failure effect observed at the subsystem boundary. For a diesel generator a failure mode is 'Fail to start on demand'

Redundancy design intention overview by redundant and common component groups		
Redundant A groups	Common/connecting groups X groups	Redundant B groups
Thruster System A T1, T3		Thruster System B T2, T4
Dependent on		Dependent on
Power System A Diesel generators A; DG 1 DG2 Main switchboard A; SWB A	SWB X	Power System B Diesel generators B; DG3, DG4 Main switchboard B; SWB B
Operator Station A: DPP A, DPD A, TRB A, OSC A		Operator Station B: DPP B, DPD B, TRB B, OSC B
DP LAN A: DPSW A, Net A1, A2, A3	Net X1, X2, X3 and X4	DP LAN B: DPSW B, Net B1, B2
DP Controller A: DPC A, Bus A		DP Controller B: DPC B, Bus B
IO System A; IO A1, IO A2		IO System B: IO B1, IO B2,
Sensor System A: Gyro 1 Gyro 3, VRU 1, VRU 3, Wind 1, Wind 3		Sensor System B: Gyro 2, VRU 2, Wind 2
Posref System A: DGPS 1, Laser		Posref System B: DGPS 2
Power Distr A: UPS A, Power A1, A2, A3, A4		Power Distr B: UPS B, Power B1, B2, B3

Fig.10. Above table indicates the thruster redundancy design intention and the system dependencies of the thruster group. In the single failure analysis all subsystem shall be used as starting points for single failures. The task is to identify possible failure modes from the subsystems which may violate the overall redundancy design intention and the overall acceptance criterion. The result of the study should be described in an FMEA worksheet in the next table.

Sub-system failed	Failure Mode/ Common cause	Failure detection methods	Effect on other sub-systems	Compensating measure	Global effect at unit (U)	Reference to test or verification
DG1	DG1 stop, Generator breaker closed	Alarm	No effect or higher load DG2	Breaker T1 open	DG3 or DG4 running T2 and T4 positioning	Ref test #1 Stop DG1 and check alarm and effect
DG1	DG1 stop Generator breaker opened
.....					

Fig.11. Example of FMEA worksheet where the results of the single failure investigation analysis of all subsystems shall be described.

The failure propagation analysis for each subsystem shall conclude on the following questions:

- Is there a need for testing/verification of functionality or compensating measures? Refer to specific test in a test program.
- Is there a need for further failure analysis inside the subsystem boundary? (e.g. for FMEA of thrusters, DP control systems, mode selector, PMS ...). Refer to subsystem FMEA for single and redundant subsystem
- Can any single failure mode in the subsystem violate the unit acceptance criterion?

When all subsystems have been analysed, the results shall be summed up in a main conclusion and the test program shall be completed. Later the test program shall be carried out and the results from the sea trials shall also be completed and concluded.

The plan is to submit the guideline on a formal external hearing in the beginning of 2011.

Summary

In parallel with the described changes to the fast growing DP market, DNV has developed new notations and guideline documents. The elements in these new initiatives have been described in this paper and can be summarized as follows:

- New DPS notation series. These notations correlate with the IMO MSC/Circ. 645 equipment classes; however on specific items the requirements are lower than the traditional DNV DYNPOS notations.
- The existing DNV DYNPOS notations will remain unchanged; this implies additional requirements to achieve higher availability and robustness as compared to DPS notations.
- The new optional DNV DYNPOS-ER (Enhanced Reliability) is a new notation additional to the existing notations for dynamic positioning systems. It is based on new principles and philosophy in order to set requirements to redundant DP systems with high availability of power and thrust. DYNPOS-ER has no direct relation to the IMO MSC/Circ.645 and should not be classified in terms of IMO equipment classes.
- The “Enhanced System Verification” rules establishes the framework for requirements to earlier, deeper, and broader testing and verification by use of various verification methods. Application of this voluntarily notation gives the users verification additional to the minimum requirements. So far the generic requirements are specifying requirements for the Enhanced System Verification by use of HIL testing.
- A new guideline for FMEA of redundant systems is being developed. The aim is to provide a standard by the end of 2010 which can help to improve the overall quality of FMEAs of redundant ship systems.

Together the DNV initiatives support the different industry needs in a steadily growing and more diversified DP market.