



DYNAMIC POSITIONING CONFERENCE  
October 12-13, 2010

**NEW APPLICATIONS SESSION**

---

**DP Power Plant  
Open Bus Redundancy With Reliable Closed Bus Operation**

**By Saurabh Shah and Kamal Garg**

***Schweitzer Engineering Laboratories, Inc., Pullman, Washington, USA***

---

## **Abstract**

Closed bus-tie operation of power plants provides superior tolerance for dynamic positioning (DP) power plant faults. However, a vessel operating with closed bus-tie breakers is not guaranteed to retain thrusters during certain types of power system failures. In these situations, rapid recovery of equipment is critical for meeting DP2 and DP3 minimum requirements of station-keeping. Open bus ties are often used when rapid recovery is inadequate to meet operational needs and retention of thrusters is necessary. Operating with open bus ties reduces overall power plant reliability but maintains availability of thrusters during any equipment fault.

This paper presents a design that can provide the desired reliability of closed bus-tie operation while providing nearly the same thruster retention capability as open bus-tie operation. Using advanced fault detection and plant management techniques, faults that would typically result in the loss of all thrusters on a closed bus-tie power plant can now be handled such that sufficient thrusters remain operational to continue DP operations even after the fault.

Power plant reliability is critical for the operation of DP vessels. DP vessel power plants are islanded power systems with four to eight generators operating in droop modes with total load demands commonly exceeding 50 MW. There are several common failure modes of the engine, synchronous machine, governor, and exciter systems that cause a complete blackout of the onboard power system. In the past, the offshore drilling industry has experienced single undesirable electrical system outages (blackouts) that have resulted in revenue losses of millions of dollars. This makes a reliable electrical power system protection and control package critically important for offshore vessels.

This paper explains several critical protection areas for offshore vessels and the failure modes currently affecting these vessels, including failure or misoperation of generator exciters and governors, islanding of defective generators, and fast fault detection and clearing in electrical machinery. The criticality of designing complete systems for simplicity, robustness, maintainability, testability, local support, ease of commissioning, longevity, and availability is also explained.

This paper concludes with a design discussion of a protection and control system for offshore vessels using the latest technology and development in the area of protection and control. This includes a detailed design discussion of a proposed system for a DP vessel. A discussion of improving the reliability of a power plant, including an overview of the communications architecture, hardware designs, and visualization system, is also provided. Additionally, the paper discusses the enhancement of the system design and many additional technological enhancements previously unavailable, such as real-time system monitoring, harmonic analysis, advanced visualization, ultra-high-speed protection, IEC 61131 programming, synchrophasors, IEC 61850, and modern communications protocols. This paper also addresses the importance of reliability.

*Index Terms*—Offshore vessel, power management system (PMS), load shedding, common-mode failure, harmonic analysis, advanced generator protection, IEC 61850, Generic Object-Oriented Substation Event (GOOSE), exciter, governor, automatic transfer, black start, synchrophasor, arc flash, automatic synchronizer, decoupling, real-time digital simulations.

## **I. Offshore Platforms and History**

An offshore platform is often referred to as an oil platform or oil rig that houses workers and machinery needed to drill wells in ocean beds to extract oil, natural gas, or both. Around 1891, the first submerged oil well platforms were built in the fresh water of Grand Lake St Marys in Ohio. In the early 1930s, the Texas Company developed the first mobile steel barges for drilling.

The two main types of drilling platforms are fixed and floating. Floating platforms have various degrees of compliancy. Neutrally buoyant structures (i.e., semisubmersibles, spars, and drilling ships) are dynamically unrestrained and can have six degrees of freedom (heavy, surge, sway, pitch, roll, and yaw). Positively buoyant structures, such as tension leg platforms and tethered buoyant towers or buoyant leg structures, are tethered to the sea bed and are heavily restrained [1].

## II. Typical Offshore Platform and Protection System

### A. Electrical System

Fig. 1 shows a typical dynamic positioning (DP) offshore system one-line diagram of a power plant on an ultra-deep-water drilling rig. In this example, the vessel has six main generators rated at 5.37 MW each, six to eight bow or stern thrusters rated at 2.3 MW each, and variable-frequency drives to operate the system. There are two main 11 kV buses connected via the bus-tie breakers that are sometimes operated normally open. Grounding transformers are provided at both main 11 kV buses. Each 11 kV main bus supplies power to a 600 V bus for drilling.

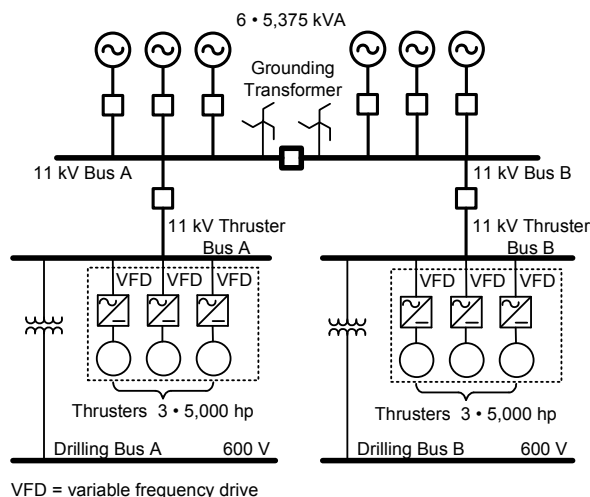

Fig. 1 Simplified Electrical System Example 1

The thrusters may have dual feeds that can draw power from both buses. The 11 kV bus is a radial bus with a bus-tie breaker that is fully insulated to provide protection against short circuits. However, for some offshore platforms, generation voltage can be 4.16 kV. An example of this type of vessel is shown in Fig. 2.

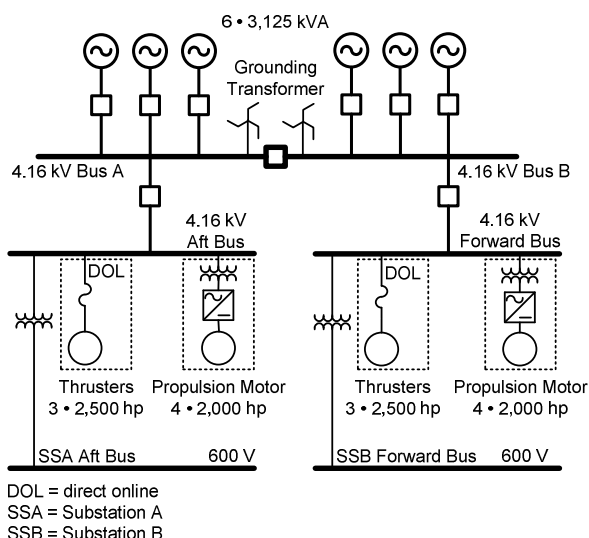

Fig. 2 Simplified Electrical System Example 2

### B. DP Vessel Class

A DP vessel is a unit or vessel that automatically maintains its position (fixed location or predetermined track) exclusively by means of thruster force and includes components such as power systems, thrusters, and DP control systems. A DP system consists of components and systems acting together to achieve a sufficiently reliable position-keeping capability. The necessary reliability is determined by the consequence of a loss of position-keeping capability. The larger the consequence, the more reliable the DP system. There are four major classes of DP vessels, as shown in Table I.

TABLE I  
DP VESSEL CLASS SUMMARY

Class	(A) Consequence	(B) Operator Impact	(C) Redundancy
1	Catastrophic	Immediate	No redundancy
2	Critical	Moderate	Reduced redundancy
3	Serious	Observational	Redundant
4	Minor	n/a	n/a

Different DP vessel classes have different types of system redundancy in operation. Redundant components and systems should be immediately available with such capacity that the DP operation can continue until the work in progress is terminated safely. The transfer to a redundant component or system should be as automatic as possible, and operator intervention should be kept to a minimum. The transfer should be smooth and within acceptable limitations of the operation. For Equipment Class 1, loss of position may occur in the event of a single fault. For Equipment Class 2, a loss of position is not to occur in the event of a single fault in any active component or system.

Class 2 single-failure criteria include:

- Any active component or system (generators, thrusters, switchboards, or remote-controlled valves).
- Any normally static component (cables, pipes, or manual valves) that is not properly documented with respect to protection and reliability.

For Class 3, a single event may include static components.

*Class 1 Consequence (Catastrophic):* A failure due to major system failure that causes total loss of DP capability regardless of any limitations put on the vessel. This means a loss of station-keeping ability, leading to an excursion, drive off or drift off from position, and an immediate termination of the operation.

*Class 2 Consequence (Critical):* A failure due to major system failure that causes loss of DP capability if operational limitations are not adhered to. This includes loss of redundancy where a further failure may cause a loss of position.

*Class 3 Consequence (Serious):* A failure that affects operational capability but does not result in termination of the operation.

*Class 4 Consequence (Negligible):* A failure that has a negligible effect on the system or subsystem level, generally at the component level, and results in a minor unscheduled repair consequence.

### C. DP Power Systems

DP power plant systems are different than utility power systems, which consist of many generators and transmission lines, shown as the Utility source and transmission line  $X_L$  in Fig. 3. The local generation and load, which are small compared to Utility, are shown as Local. However, in the case

of DP offshore vessels, the power system consists of local generation and load only. This type of power system is defined as an islanded power system when there is no connection to the utility or grid and local generation is the only power source for loads.

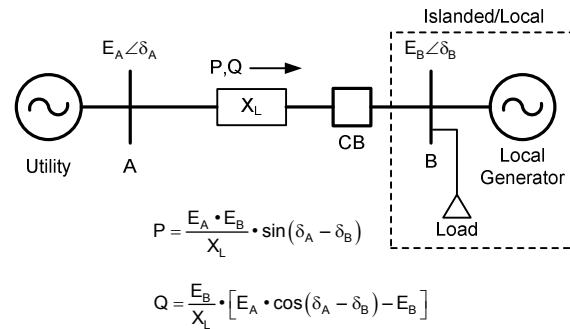

Fig. 3 Simplified Utility Power System

For the utility power system, the power flow between the Local and Utility sources depends upon the angle between the two systems and line impedance, as shown in Fig. 3. Fig. 4 shows that as load increases, the power flow increases until the internal angle ( $\delta$ ) difference is 90 degrees (refer to the power flow curve). The utility system, as shown in Fig. 3, is more stable in comparison to the islanded system and can ride through various system transient conditions because the larger inertia of a utility system is inherently stable for small disturbances. However, there may be local or inter-area oscillations if the local generation is weak and connected via long lines or a weak network.

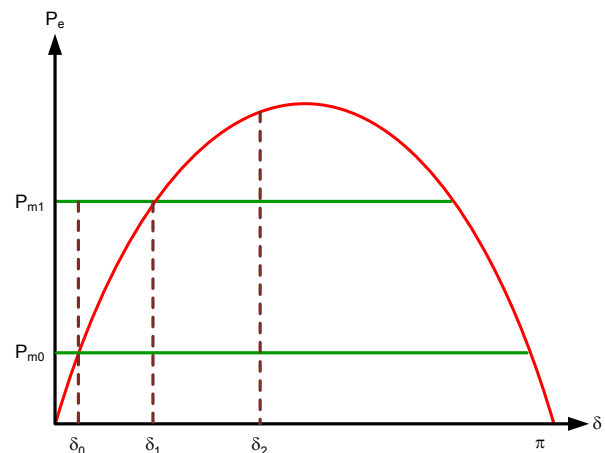

Fig. 4 Power Flow Example

Because DP offshore platforms are islanded power systems, the reliability of power plant

operation is very important. A single outage can result in millions of dollars in revenue loss. For DP vessels, system inertia is relatively small, and even short system disturbances may result in the system becoming unstable. Detailed dynamic studies are required for various system configurations, and critical clearing time (CCT) should be determined. In some cases, special protection schemes are required to island the faulty section or shed load.

#### *D. Closed Bus Operation and Motor Bus Transfer*

Closed bus-tie operation of power plants provides superior tolerance to DP power plant faults. However, a vessel operating with closed bus-tie breakers is not guaranteed to retain thrusters during certain types of power system failures. The proposed solution discusses DP vessels with a normally closed bus-tie breaker. The critical load on DP vessels is the thruster load. High-speed bus protection detects the fault and islands the faulty bus section in less than 5 cycles, including the breaker operating time. For a fault in any other section or equipment, the respective protection islands the system as soon as possible. However, it is possible that depending upon the severity of the fault, critical loads (i.e., thrusters) may drop out for the fault. Hence, to improve system reliability, it is required to reconnect and re-energize the thrusters as soon as possible in order to restore the system and critical loads. The following sections discuss various bus transfer schemes and a proposed solution for DP vessels.

Motor bus transfer (MBT) schemes are very popular for power plants. To maintain process continuity, motor buses may require transfer from a present source to a new source. The reasons for this may be fault clearing on the present source, deliberate transfer from a utility source to an on-site source during storm periods or for rate savings (and back to utility power at a later time), and de-energization of the present source for maintenance or construction. During the MBT schemes, electric motor-driven equipment decelerates because power sources are removed. The deceleration rate depends upon the inertia of drives and the synchronizing power flowing between the motors due to trapped relative flux. As the motor decelerates, the relative angle between the power source and internal angle of the motor increases. The motor flux decay depends upon the motor time constant and power flow between

motors. The decay rate of internal voltage depends upon motor flux and motor speed, which are functions of load torque, moment of inertia, and real power transfer between motors. If the relative angle is large at the time the breaker is closed, with significant flux and resultant voltage, an inrush that is larger than the normal inrush current may result. These high currents can cause high-winding forces and transient torques that can damage rotating equipment.

Motors with adjustable speed drives (ASDs) have different characteristics during the high-speed bus transfer compared to motors without ASD. Large ASDs typically have dc links, source-side converters, and motor-side inverters. Because of the pseudo isolation created by the dc links, the drive system machines are not connected synchronously to the rest of the system. ASD machines are not usually subjected to severe transient torque as a result of the transfer; however, a detailed transient study should be performed to verify the design of the fast transfer scheme.

The transfer schemes can be categorized as follows:

- Parallel or closed circuit
- Fast simultaneous
- Fast sequential
- Residual
- Long time

#### *1) Parallel or Closed-Circuit Transfer*

In a parallel transfer, the new source is connected to the motor bus before the old source is tripped. The intent is to transfer sources without interruption. The phase angle and voltages from the motor bus and the new source are evaluated prior to the transfer to ensure that the motor bus and the new source are in synchronism or the new source lags or leads the old source by an acceptable amount. This method is widely acceptable for routine source transfers because transients on the motor bus are eliminated. If the two sources are not derived from the same primary source and a large-standing phase angle is present between them, the opportunity for a hot parallel transfer is eliminated.

Assuming the two-source phase angle relationship is acceptable and two sources are paralleled, currents flowing into and through the bus may violate the interrupt rating for the circuit breakers and the short-term withstand ratings of the source transformers. A fault occurring either on the

bus or on one of the sources when the sources are paralleled can overstress the components of the bus system.

#### 2) *Fast Simultaneous Transfer*

In a fast simultaneous transfer, a trip command is issued to the present source breaker and a close command is issued to the new source breaker at the same instant. The phase angle and voltages from the motor bus and the new source are evaluated prior to the transfer to ensure that the motor bus and the new source are in synchronism or the new source lags or leads the old source by an acceptable amount. The close command is unsupervised. This is the fastest transfer type that does not parallel the sources.

#### 3) *Fast Sequential Transfer*

In a fast sequential transfer, the present source is tripped, and as soon as the present source breaker has started to open (typically indicated by an “early b” contact), a close command is issued to the new source breaker. The close command may be supervised or unsupervised, depending on the transfer method employed. This is the second-fastest transfer type that does not parallel the sources.

In order to make a rapid blocking decision, specialized synchronism-check equipment should be employed to make decisions on a moving phase angle in the shortest time possible, typically 1 to 2 cycles. If the synchronism-check equipment reacts too slowly, a transfer could be allowed when the phase angle value is actually in violation of the settings. An unsupervised fast sequential transfer is faster than a supervised sequential transfer because the supervised transfer process must include a small delay to allow synchronism-check measurement and possible transfer blocking to occur.

#### 4) *Residual Transfer*

In a residual transfer, the motor bus is connected to the new source after the voltage on the coasting motor bus falls to less than 0.25 pu. In this manner, regardless of the phase angle value, the resultant volts per hertz (V/Hz) will not exceed 1.33 V/Hz.

This is the third-fastest transfer type that does not parallel the sources. However, this transfer type may not be fast enough to maintain process continuity, because certain motor loads that cause rapid stalling may necessitate a restart of the motors on the bus.

#### 5) *Long-Time Transfer*

In a long-time transfer, the motor bus is connected to the new source after a time delay that reflects that the voltage on the coasting motor bus has fallen to less than 0.25 pu. In this manner, regardless of the phase angle size, the resultant V/Hz will not exceed 1.33 V/Hz. This is the fourth-fastest transfer type that does not parallel the sources. However, this transfer type may not be fast enough to maintain process continuity, because certain motor loads that cause rapid stalling may necessitate a restart of the motors on the bus.

### III. Proposed Solution

Fig. 5 shows the conceptual block diagram for a DP offshore power management system (PMS) protection scheme. The proposed scheme is dual redundant, and two independent sets of local protection are included to improve system reliability [2]. Generator protection is included in the local protection block, which communicates with the generator control block. Local protection devices communicate via direct fiber relay to relay or via IEC 61850 protocol using Ethernet in the system protection block. System Protection 1 and 2 are the hub of all the decisions for PMS control and data exchange. The system protection processes all of the relevant information from local protection and provides control and decisions for the PMS. By properly collecting, manipulating, and presenting power system data as usable information, the system enables operations, maintenance, and engineering staff to diagnose system events, predict equipment failures, and minimize unnecessary maintenance. The proposed solution also guides operators in making decisions, such as controlling black start, manual override, and load shedding. The solution includes a human-machine interface (HMI) screen for system overview and control.

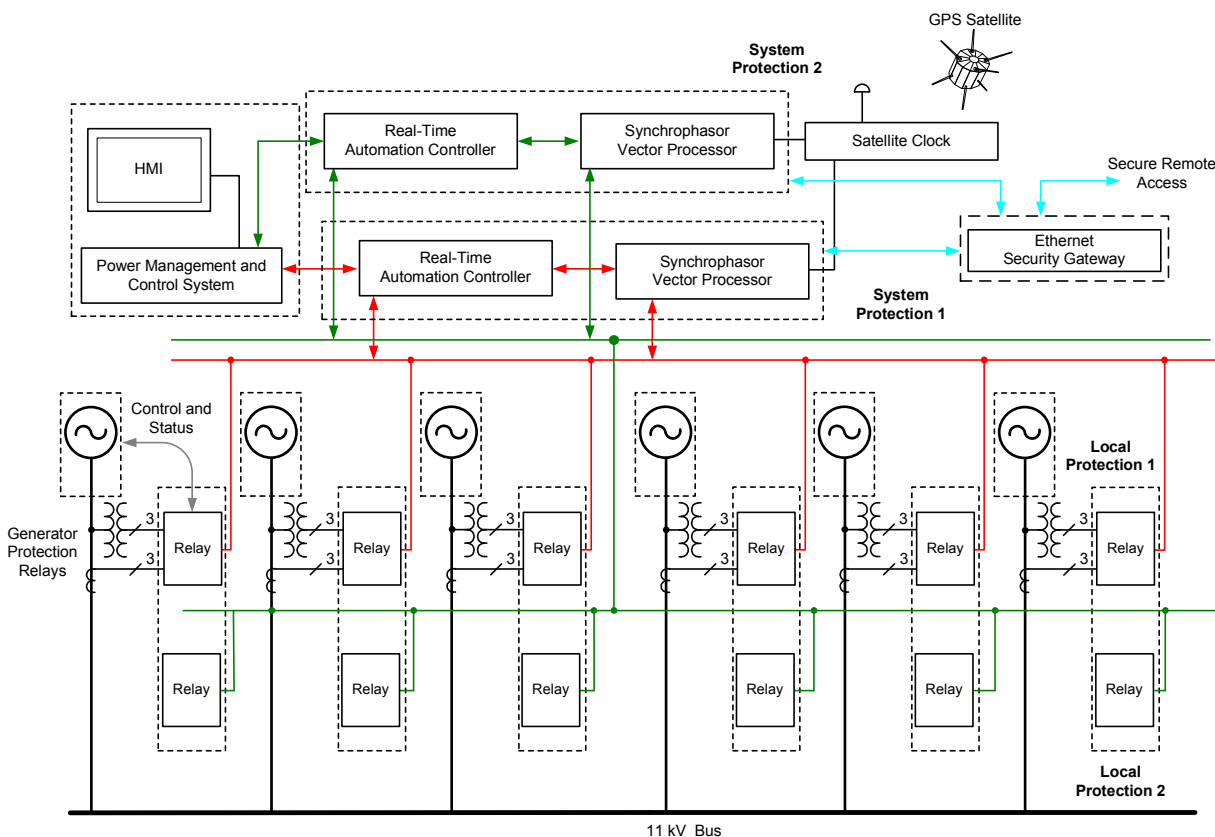

Fig. 5 Proposed Solution—Redundant Protection

The fast sequential MBT scheme is proposed for DP vessels using high-speed breakers and technology to minimize deceleration to a level that limits the motor inrush current to an acceptable level. Because the bus-tie breaker will be operated in the closed position, 11 kV Bus A and Bus B will have the same angle (refer to Fig. 1). Considering the scenario that the fault occurred in Bus Section B, protection will operate and island Bus B for this fault in 3 to 5 cycles. It is quite possible that thruster motors may also drop for this fault or variable frequency drive (VFD) operation may be blocked due to the VFD algorithm. A stability study will determine a three-phase bus fault CCT [3]. If generators can withstand a 3-to-5-cycle, three-phase bus fault, then the generators can run for this fault and re-energize the thrusters using the high-speed bus transfer. Synchrophasor technology will also be applied to detect the system conditions and decide the appropriate closing conditions. The protection system includes voltage and angle of both systems ( $E_S$  and  $E_M$ ). Using the slip calculations, an appropriate command to re-energize the islanded thruster can be issued for a

direct online (DOL) motor start. Fig. 6 shows the importance of the correct closing angle in order to perform a successful transfer.

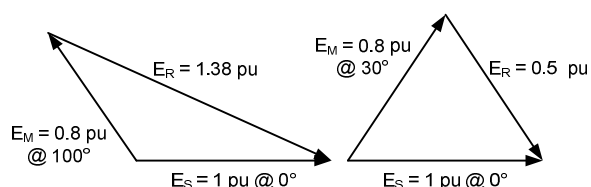

Fig. 6 High-Speed Motor Transfer (Resultant Voltage)

In Fig. 6:

$E_S$  = system equivalent V/Hz; system voltage in per unit of motor-rated voltage divided by the system frequency in per unit of rated frequency.

$E_M$  = motor residual V/Hz; motor terminal voltage in per unit of motor-rated voltage divided by the motor speed in per unit of synchronous speed.

$E_R$  = resultant vectorial voltage in per-unit V/Hz on the motor-rated voltage and frequency base.

An important value used to decide the viability of MBT is the resultant V/Hz derived from the V/Hz vectors of the motor bus and the new source at the instant just prior to connection. This value should not exceed 1.33 V/Hz [4].

*A. Local Protection*

The local protection block includes generator protection relays. For the existing scheme, only one relay per generator is proposed. However, when redundancy is required, more than one generator protection relay is installed per generator. The proposed generator protection relay includes the protection elements shown in Fig. 7. The following additional optional generator protection elements can also be programmed:

- Field ground (64G)
- Compensator distance (21C)
- Out of step (78)

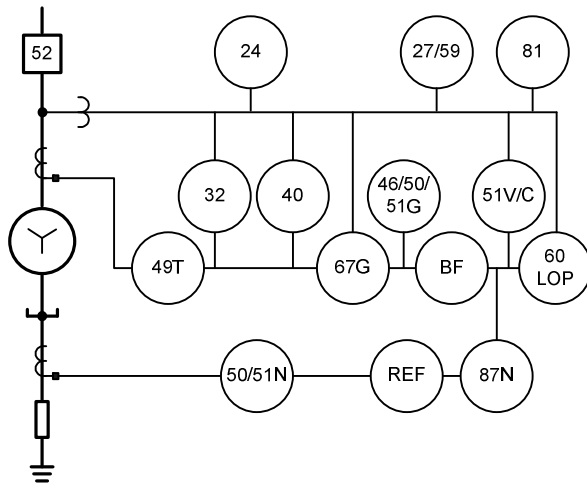

Fig. 7 Standard Features of Generator Protection Relay

The generator protection relay provides exciter and governor control, in addition to automatic synchronization. An example of automatic synchronization is shown in Fig. 8, and the report is shown in Fig. 9. Generator protection is also involved in the common-mode protection of the generators.

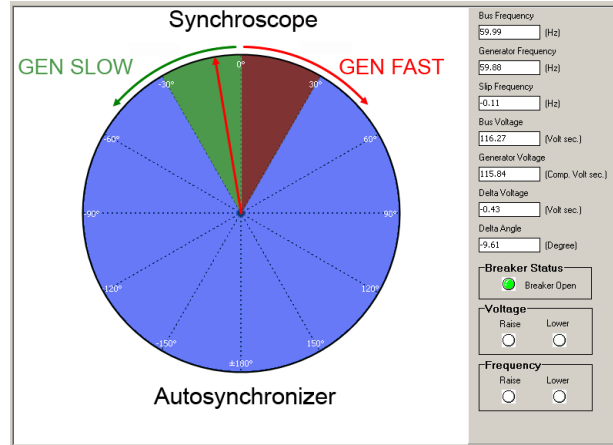

Fig. 8 Automatic Synchronization

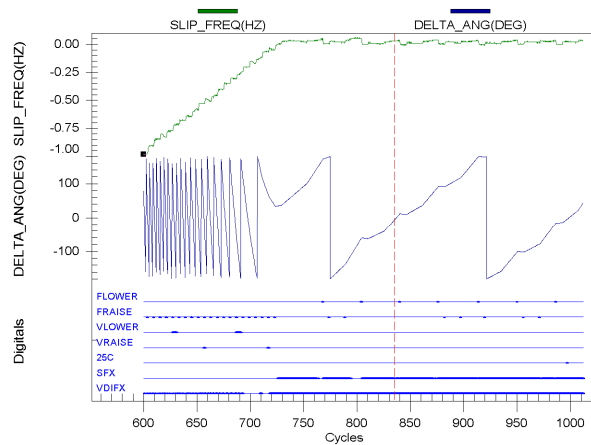

Fig. 9 Example Automatic Synchronization Report

*B. System Protection and the PMS*

System protection provides the function of a data concentrator and includes all of the control for the PMS. Based on the overall DP system protection review, any additional protection, such as feeder, bus, motor, and transformer protection, is included as part of the system protection. The PMS also provides the following functions:

- Load-dependent start and stop
- Generator running order selection
- Load shedding
- Heavy-consumer start block
- Blackout start capability
- Diesel engine control

The PMS provides the control for generator start and stop based on the loads and priority of the generator to start the assigned units in the sequence as required [5] [6]. Local generation can support 100 percent load during normal operation; however, during the outage of some units, a load-shedding scheme is enabled. Algorithms (i.e., priority loads to shed) must be designed into the system in order to react properly. The system remains operational and dynamically recalculates control set points under all system bus configurations. The PMS provides the control and start and stop of all generators.

The PMS includes protective relay front panels that automatically provide text and status point displays that serve as a backup interface to the data acquisition and monitoring system. The relays are configured so the front-panel direct action pushbuttons operate as a backup control interface. The relay control interface includes a lock function that prevents accidental operations.

### C. Communication and Integration to the PMS

Fig. 5 shows the complete system with communications and PMS integration. The proposed scheme uses fiber optics and MIRRORING BITS® communications to communicate between various components [7]. These communications are self-monitored. The user is automatically notified of any communications failure. Alternatively, the system can be designed using IEC 61850 protocol and Generic Object-Oriented Substation Event (GOOSE) messaging. As an option, systems can be designed using both IEC 61850 and MIRRORING BITS communications. The system protection block collects all of the information from the local protection block, and the correct

sample rate is selected based on proper testing and design. Additionally, the proposed system is capable of providing a secure communications gateway via standard protocols, such as Modbus® and DNP3. Fig. 10 shows an example of a black-start generator using the PMS.

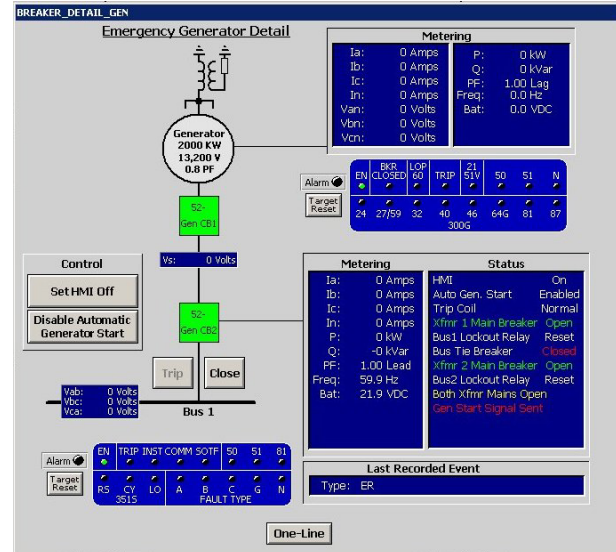

Fig. 10 Example Black-Start Generation Fault

### D. Engineering Diagnostics and Analysis Tools

The proposed solution includes various built-in tools for system analysis and self-diagnostics. All of the relays and protection functions are self-monitoring and record any system discrepancy. Operators receive visual alarms. Using the PMS, the HMI continuously displays the operating parameters and custom screens with alarm details. A separate screen is developed for each system component. The proposed system is programmed to send important information to key personnel for critical alarms.

The proposed PMS solution automatically archives sequence of events (SOE) records from all of the relays. SOE records generate comma-separated value (CSV) files with accurate satellite clock time stamps. The event report is archived in the PMS. This information can be used for the analysis of any system operation. Fig. 11 displays an example event report, where for the three-phase fault, phase angle, reverse overcurrent (OC) and undervoltage protection pick up and clear the fault.

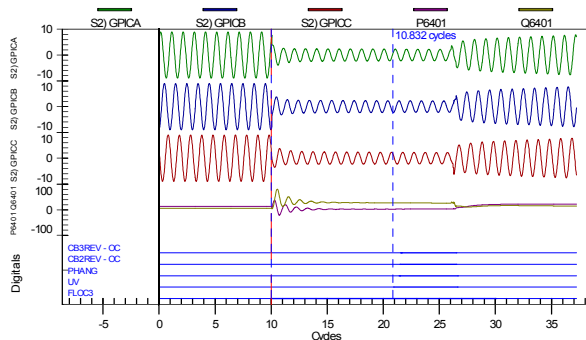

Fig. 11 Example Fault Analysis for the Three-Phase Fault

### E. System Security

Security of the PMS is critical so that no unauthorized actions are allowed. The proposed solution includes various layers of security from the relay all the way to the HMI. The HMI has a minimum of four different types of access levels that allow certain types of control or operation (operator, maintenance, supervisor, and administrator). Additional levels can be added as necessary. All Ethernet communication within the PMS is isolated from all other Ethernet networks. Products used have the following security features:

- Strong password capability, requiring uppercase and lowercase letters, numbers, and special characters.
- Six-character passwords using a 90-character alphabet, yielding 68 billion possible passwords.
- Multilevel access control, giving personnel access only to the functions that they require.
- Real-time access monitoring and alarms, which inform of access attempts.

“Defense in depth” strategies are employed for the security of the entire system. This strategy is to provide multiple layers of defensive mechanisms implanted in the products and the system as a whole. This can include electronic security

perimeters, such as firewalls or serial communication between systems, strong product security features, malware detection, elimination of Microsoft® operating systems, and active overlapping zones of product failure detection [8] [9].

### F. Additional Features

In addition to the functions of the PMS and generator protection, the proposed scheme includes the following features:

- Synchrophasors
- Feeder protection and arc-flash detection
- Transformer protection
- Bus protection
- Motor protection
- Common-mode generator protection

#### 1) Synchrophasors

A definition of real-time (synchronized) phasors is provided in IEEE 1344-1995. Applying synchrophasors improves performance for critical applications. As stated earlier, each machine state is based on highly accurate Global Positioning System (GPS) satellite clock signals and synchrophasor data [10]. Fig. 12 shows the phasor measurement of multiple machines. The logical comparison of the synchrophasor variables is performed using system protection.

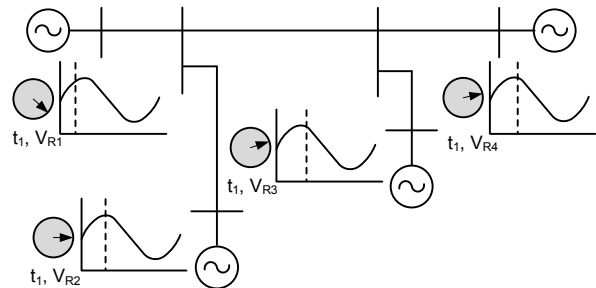

Fig. 12 Synchrophasor Measurement

Synchrophasors can be applied to visualize the overall system performance with reference to the same time frame, and the data can be automatically archived for future analysis. Using modal analysis (included in system protection), it is also possible to calculate the resonance and oscillation frequencies. This information is critical for advanced generator protection design. Existing DP vessel common-mode generator protection cannot detect the resonance and oscillation frequency accurately.

### 2) Feeder Protection and Arc-Flash Detection

Arc-flash detection is important for the safety of the personnel working on a DP vessel. Fast, reliable operation of an arc-flash protective relay improves safety and reliability. The proposed solution provides feeder protection and arc-flash detection. Using advanced technology, faults can be detected in 2 to 3 milliseconds, limiting the arc-flash damage to switchgear. Feeder protection and arc-flash detection are included in the same relay. The feeder relay includes the following protection functions:

- Phase and neutral overcurrent
- Under-/overvoltage
- Under-/overfrequency
- Breaker failure
- Arc-flash detection
- Rate of change of frequency (df/dt)

A detailed arc-flash study, appropriate personal protective equipment (PPE) selection, system design, field commissioning, and product support are also included. Fig. 13 shows a solution for arc-flash detection.

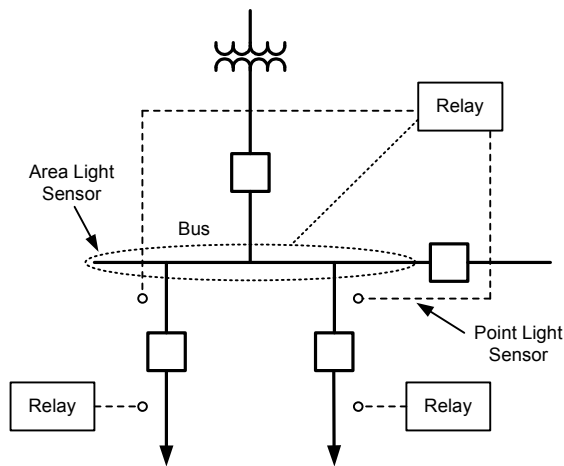

Fig. 13 High-Speed Arc-Flash Detection

Up to four sensors, point and loop, are installed in this solution, and all of the switchgear sections are protected using selective tripping. As part of an arc-flash study, possible ways to reduce the

arc-flash category are determined, and appropriate warning labels are posted at various switchgear locations to instruct people to use appropriate PPE. This defines the working boundary for qualified personnel.

Fig. 14 shows the arc-flash labels to be installed at each major panel and switchgear location to allow only personnel with appropriate PPE to work in the area identified by arc-flash labels.

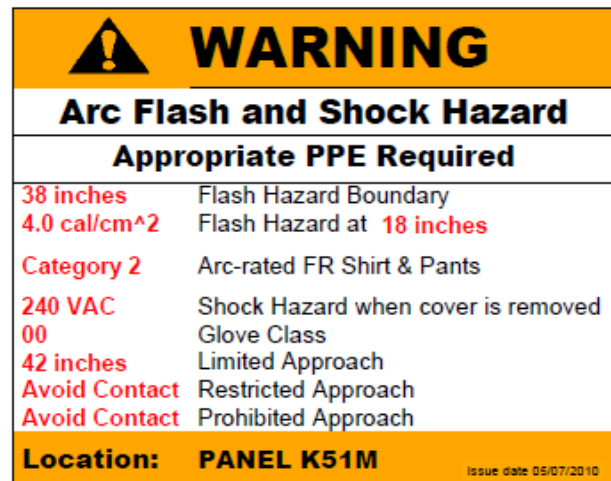

Fig. 14 Example Arc-Flash Label

### 3) Other System Protection

In addition to the protection discussed, other overall system protection, such as motor protection, bus protection, and transformer protection, is also provided as part of this solution. The proposed solution uses the same relay for transformer and bus protection. The bus and transformer protective relay is capable of handling five three-phase current transformer (CT) inputs and three single-phase CT inputs for restricted earth fault (REF) protection. The proposed relay is based upon low-impedance bus protection. Low-impedance bus protection is faster at detecting a fault compared to high-impedance bus protection, in addition to other advantages [11]. A motor protection relay includes all of the protection functions required for the motor, including the thermal model.

An example motor starting report is shown in Fig. 15 [12]. In addition, one high-speed MBT relay is installed for each important motor. The MBT relay is the same as the bus and transformer protection relay. Selecting the same type of relay to protect pieces of equipment reduces the engineering and training time.

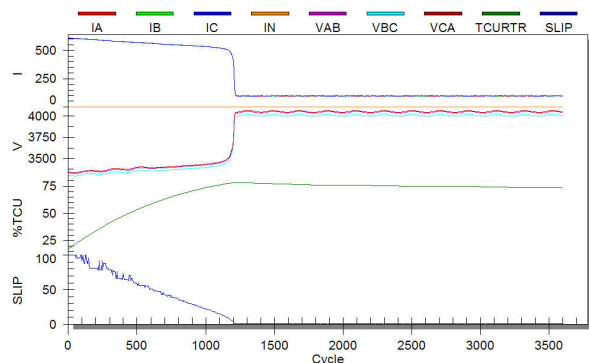

Fig. 15 Example Motor Starting Report

#### 4) Common-Mode Faults

Common modes of failure are defined as faults that affect overall system operation and cause multiple redundant elements to react adversely. For normal operating conditions, all of the generators operate in parallel droop mode. In case of a fault on one generator exciter and governor or any other common-mode fault, it is desirable to properly detect and isolate only the faulty generator from the system as soon as possible [13]. It is also necessary to evaluate the response time of controls (e.g., exciter and governor controls) before making decisions regarding any system isolation or islanding. Otherwise, undesirable system operation may result in additional faults or failures. This solution will correctly detect and island for all of the faults discussed below. Common-mode faults are classified in the following four categories:

- Governors
- Fuel or actuator
- Exciters
- Miscellaneous

## IV. Other Critical Issues

### A. Model Power System Test and Example

The model power system testing laboratory is the proposed site for complete testing of systems using the Real Time Digital Simulator (RTDS®). RTDS equipment allows dynamic modeling of a power system with a simulated small time step to test all closed-loop controls and protection systems [11]. The DP power system will be modeled using RTDS, and system performance will be benchmarked using the actual field results.

An example of generator parameter verification using load shedding is shown in Fig. 16. The RTDS system study helps with relay settings and verifying the correct protection system operation of offshore vessels for system contingency conditions, system dynamics, and transient faults. This dynamic system model is utilized for the verification of PMS integration for black-start operation, load shedding, and fast MBT schemes. The system performance is also verified during field installation.

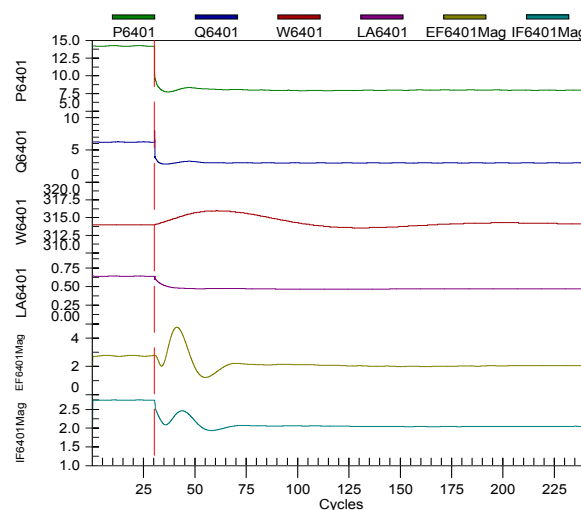

Fig. 16 Generator Results Benchmark Using RTDS

### B. Design Verification

The PMS is designed and validated in the laboratory before it is deployed in the field. Critical systems such as DP require testing controllers and associated equipment during factory acceptance testing. These critical systems need to have their controls validated and tested in a real-time simulation environment. Using this type of validation and testing helps in accurately modeling governors, turbines, exciters, rotating machinery inertia, load and electrical characteristics, electrical component impedances, and magnetic saturation of electrical components.

Fig. 17 shows an example of RTDS results that help monitor the system parameters in real time. T114-P, T114-Q, and T114-TAP show the power flow and tap position for the T114 transformer. Similar information is shown for the T115 transformer. In addition, Fig. 17 shows the currents (ICB3A, ICB3B, ICB2A, and ICB2B) and bus voltage (GPIC1A and GPIC1B).

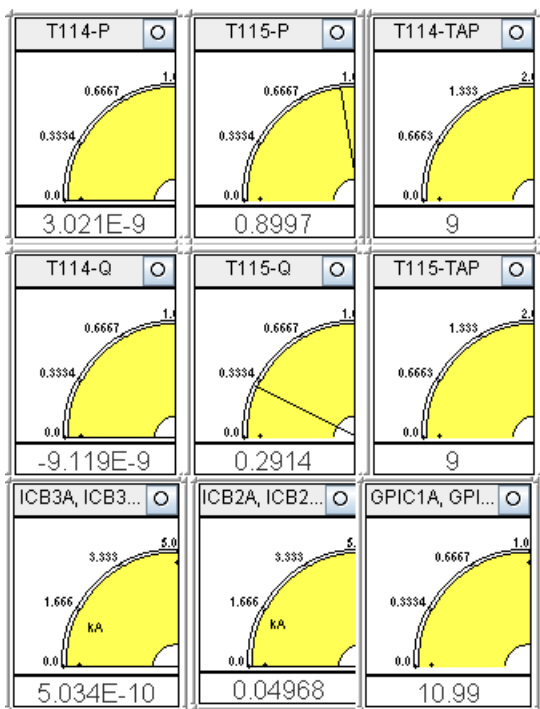

Fig. 17 Example System Results Using RTDS

The RTDS testing verifies the system design, protection settings, and overall system performance [13]. Thousands of faults and system disturbances are created and tested in a closed-loop system, evaluating the system performance even before the PMS is installed on-site. In addition, the results of on-site testing are used to revalidate the system design. Once the standard DP system model is built, it can be easily applied for future system expansion and design variation. This tool has been used for various projects with complicated system designs where settings are dependent on the system design parameters. Without detailed testing, selecting proper protection is not possible.

### C. Off-the-Shelf and Complete Engineering Solutions

The proposed system configuration is shown in Fig. 5. The system can be designed using redundant protection or only single protection per generator. However, the incremental cost of additional protection is small in comparison to the overall project cost. System reliability is also improved by selecting redundant protection. The proposed design is easily expandable and can be applied to any type of offshore platform. For this example project, only six generators are installed; however, this system is easily expandable for vessels designed with more than six generators. As part of this engineering solution, a test bed serves as a valuable test lab for engineers to evaluate system performance. The proposed scheme can be a template for future designs and result in reduced engineering costs. Once the system is designed and tested for one vessel, the same design is easily applied to other vessels. The costs of training, maintenance, and system operation are also reduced because of the standard system design.

Detailed documentation and local support are best provided on location. Deep-water drilling platforms are located all over the world, so support and training for these critical projects are required “as needed” and “when needed.” The global presence of a support company is important to the acceptance and success of the project.

## V. Conclusion

This paper discusses the conceptual design of DP power plant protection, automation, and control using the latest technology available. It also discusses the advantages of operating the DP plant as closed bus and a solution for a high-speed motor transfer scheme. This proposed solution provides cutting-edge protection functions for generators using synchrophasor technology and the IEC 61850 protocol. In addition, the solution includes a PMS, arc-flash detection, and automatic synchronizer. This solution is robust, easily expandable, and self-diagnostic. It also provides automatic archiving of SOE and event reports. Using advanced technology and tools, a reliable PMS is designed and implemented. This paper also discusses the importance of detailed design verification using real-time simulation.

## VI. Acknowledgment

The authors gratefully acknowledge the contributions of Lew Weingarth, DP superintendent of Transocean, for providing technical support for this paper. Lew has more than 30 years of experience with DP power plants and offshore vessels.

## VI. References

- [1] S. Chakrabarti, *Handbook of Offshore Engineering*, Elsevier Ltd., Oxford, UK, 2005.
- [2] M. Oens and C. Lange, "Improvements in Feeder Protection—Providing a Primary and Backup Relay System Utilizing One Relay Per Feeder," proceedings of the 33rd Annual Western Protective Relay Conference, Spokane, WA, October 2006.
- [3] A. Jain and K. Garg, "System Planning and Protection Engineering—An Overview," proceedings of the 3rd International Conference of Power Systems, Kharagpur, India, December 2009.
- [4] T. S. Sidhu, V. Balamourougan, M. Thakur, and B. Kasztenny, "A Modern Automatic Bus Transfer Scheme," *International Journal of Control, Automation, and Systems*, Vol. 3, Issue 2, June 2005.
- [5] B. Cho, H. Kim, M. Almulla, and N. Seeley, "The Application of a Redundant Load-Shedding System for Islanded Power Plants," proceedings of the 35th Annual Western Protective Relay Conference, Spokane, WA, October 2008.
- [6] D. Miller, R. Schloss, S. Manson, S. Raghupathula, and T. Maier, "PacifiCorp's Jim Bridger RAS: A Dual Triple Modular Redundant Case Study," proceedings of the 11th Annual Western Power Delivery Automation Conference, Spokane, WA, April 2009.
- [7] K. Behrendt and K. Fodero, "Implementing MIRRORING BITS Technology Over Various Communications Media," SEL Application Guide (AG2001-12), 2007. Available: <http://www.selinc.com>.

- [8] D. Anderson and G. Leischner, "Cybersecurity as Part of Modern Substations," proceedings of the 7th Annual Power Systems Conference, Clemson, SC, March 2008.
- [9] D. Dolezilek and T. Tibbals, "Communications Technologies and Practices to Satisfy NERC Critical Infrastructures Protection (CIP)," proceedings of the 5th Annual Power Systems Conference, Clemson, SC, March 2006.
- [10] E. O. Schweitzer, III, D. Whitehead, A. Guzmán, Y. Gong, and M. Donolo, "Advanced Real-Time Synchrophasor Applications," proceedings of the 35th Annual Western Protective Relay Conference, Spokane, WA, October 2008.
- [11] L. Weingarth, S. Manson, S. Shah, and K. Garg, "Power Management Systems for Offshore Vessels," proceedings of the Dynamic Positioning Conference, Houston, TX, October 2009.
- [12] P. Whatley, M. Lanier, L. Underwood, and S. Zocholl, "Enhanced Motor Protection With the Slip-Dependent Thermal Model: A Case Study," proceedings of the 34th Annual Western Protective Relay Conference, Spokane, WA, October 2007.
- [13] A. Al-Mulla, K. Garg, S. Manson, and A. El-Hamaky, "Case Study: A Dual-Primary Redundant Automatic Decoupling System for a Critical Petrochemical Process," proceedings of the 2009 PCIC Europe Technical Conference, Barcelona, Spain, May 2009.

## VII. Biographies

**Saurabh Shah** is a branch manager in the engineering services division of Schweitzer Engineering Laboratories, Inc. (SEL). He received his BS in 1995 and AS in computer systems in 1991 from Lewis-Clark State College. He has a broad range of experience in the fields of power system operations, protection, automation, and integrated systems. He has served nearly 19 years at SEL, where he has worked in relay testing, sales, business development, and engineering project management.

**Kamal Garg** is a project engineer in the engineering services division of Schweitzer Engineering Laboratories, Inc. (SEL). He received his MSEE from Florida International University and India Institute of Technology, Roorkee, India, and a BSEE from Kamal Nehru Institute of Technology, Avadh University, India. Kamal worked for Power Grid Corporation of India Ltd. for about seven years and Black & Veatch for about five years at various positions before joining SEL in January 2006. He has experience in protection system design, system planning, substation design, operation, testing, and maintenance. Kamal is a licensed professional engineer in five U.S. states.