



DYNAMIC POSITIONING CONFERENCE
October 12-13, 2010

Arctic SESSION

Structural Monitoring Systems with applications to Ice
Response Monitoring

By Geir Sagvolden and Karianne Pran

Light Structures AS, Hasleveien 38, NO-0571 Oslo, Norway

Abstract

Fiber optic structural monitoring systems are an increasingly popular tool for ship hull fatigue life management and structural monitoring. These systems have also found a range of applications outside hull monitoring due to the excellent performance of fiber optic sensor and communication systems in harsh environments. When low noise strain measurements are coupled with structural response models, parameters such as forces, moments, displacements, and structural utilization can be extracted. Furthermore, forecasts of extremal observations based on continuous measurements of these parameters are being used to ensure that operation is within operational envelopes. We give an introduction to the measurement and processing techniques and what they offer, and use examples from an Ice Response Monitoring system installed on a Norwegian icebreaker.

Introduction

Hull Stress Monitoring Systems (HSMS) are sensor systems that employ strain gauges at strategic locations of the vessel to measure the hull response to external loads. The systems have, in the last few years, developed from alarm system to systems providing valuable guidance in vessel operation and long term safe-keeping. Most major classification societies provide special notations for vessels with hull stress monitoring systems, such as DNV (HMON), Lloyd's Register (ShipRight SEA), ABS(HM), BV(MON-HULL) and RINA (MON-HULL).

The purpose of the HSMS is to aid the navigator's judgment when operating in harsh conditions by providing objective information on the hull conditions not available through other means. Obviously, judging the actual load sustained by the vessel when navigating through a severe storm is difficult even for an experienced navigator, and even more so during nighttime conditions.

Structural parts that may be subject to overloading in special conditions are also monitored. Examples of these are tank containment systems subject to tank sloshing in special conditions, structures subject to icing loads, and hull structure at the waterline when transiting through ice-infested waters.

The actual value of the HSMS to the operator will largely depend on the ability of the system to condense the vast amount of information available from the sensors to a few parameters that are readily understood and presented. In the following, we aim to explain the basic methods that are used, and highlight the flexibility and applicability of these systems in attacking a wide range of problems.

Overload monitoring

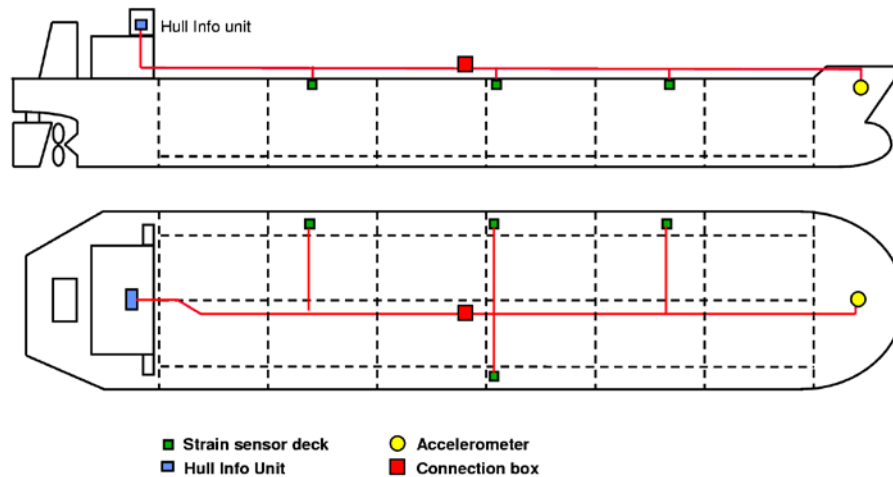

Figure 1: Typical arrangement for measurement of vertical bending moments

Early HSM systems, typically employing long base sensors based on LVDTs or resistive strain gauges at deck level, provided an alarm function in case of global overloading of the vessel. Overloading cases were typically due to cargo or ballasting operations. Also, major structural damage or water ingress are, to some extent, detectable by these systems. In extreme cases, the systems alert the operator of imminent danger to structural integrity.

As seen from Figure 1, only a few HSMS sensors are required by class to provide a global overloading measurement system. By use of structural models, the measurement at the sensor position is extrapolated to the structural details of greatest concern in its general vicinity, and allowable limits are set correspondingly. Sensors are placed to minimize the influence of any local effects and obtain an as accurate measurement of the global loading as possible. Thus even a well placed single-direction sensor may turn the hull section into a force transducer.

Transition to Fiber Optic systems

10 years ago we provided the first fiber optic system to a commercial vessel, using a technology developed for Navy projects. Since then, several projects have explicitly requested that the hull stress monitoring systems are based on fiber optic sensors, and traditional suppliers are working to provide a similar technology.

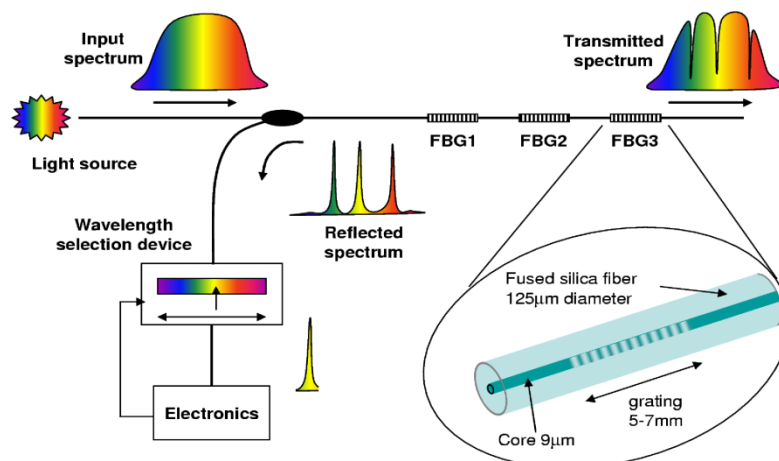

Figure 2: Principle of Bragg-grating based fiber optic sensors

Fiber optic sensors are well suited to structural monitoring systems in maritime, offshore, wind-power and civil infrastructure applications, as they provide several technological advantages.

- No electromagnetic interference, even in signal loops of several kilometers length, means that the system consistently provides low noise signals suitable for advanced processing
- Sensors are intrinsically EX safe due to the low intensities of light employed
- Glue-on fiber optic sensors have long life and are virtually maintenance free
- Sensors may be multiplexed on a single optical fiber
- The sensors tolerate placement in several difficult locations, such as in water ballast tanks and inside the containment system of LNG carriers.

Fatigue management

Critical overloading is an event that seldom occurs. On the other hand, all vessels experience development of material fatigue to some extent. To vessels operating in severe weather or vessels designed for long life, fatigue development may be a major concern and fatigue management a factor in operations.

In addition to information on overloading events, if any, the time series from the simple sensor system in Figure 1 provide a complete history of the hull loading sequence. Our systems analyze the measurements to extract the fatigue development and provide historical data for onshore analysis and current data in real-time the operator.

The rate of fatigue development is highly dependent on the amplitude of the load. Thus, even a minor operational correction may reduce the fatigue accumulation rate significantly. Correspondingly, much of the accumulated fatigue damage occurs during short periods where the accumulation rate may be orders of magnitude larger than the normal rate.

These operational «hotspots» may be due to wave loading alone, or to a combination of wave loading and vibration effects of the hull girder. Thus, to prolong vessel life and reduce maintenance cost, it is important to alert the operator of this fact so corrective actions may be carried out.

As in the case of global overloading, structural models are employed also in this case to relate the strain measured at the sensor position to the most critical stress concentration in the general area.

Onshore analysis is used to help understand the causes of fatigue development and attribute them to wave loading, vibrations and slower effects such as heating/cooling cycles and cargo/ballast operations. These data are, together with data from overloading events, important in establishing the current condition of the vessel and decide when and what to inspect in a condition-based maintenance scheme.

Active Operator Guidance

Active operator guidance provides the operator with recommendations that better allow him to plan and execute corrective actions. Recommendations may be provided for any parameter that is characterized by the system, such as fatigue accumulation rates, accelerations/motions, tank sloshing pressures, and overloading probabilities.

The recommendations are either based on a model of the vessel response or on data previously gathered on the vessel itself or other vessels in the fleet.

Damage Detection

Hull Stress Monitoring systems are not designed to detect damage. Damage detection is, in principle, possible, but such a system requires a much denser sensor grid than is realistic by any means.

Thus, the focus of the Hull Stress Monitoring systems is damage avoidance by providing new knowledge to the navigator, allowing him to keep his vessel in the safe zone.

LNG tank sloshing monitoring

The measurement of sloshing pressure pulses inside the extremely cold environment of an LNG membrane containment system serves as an example of an extreme environment where fiber optic sensor systems can be successfully applied. The “Full Scale Measurements of Sloshing in Membrane LNG Tanks” project is headed by DNV and aims to compare full scale measurements with a scale model installation, to gain better knowledge and improve guidelines for sloshing assessments. [1]

The vessel was instrumented with fiber optic pressure sensors at the primary membrane, and strain sensors through the containment system and also on the supporting steel structure.

Careful characterization of the response of instrumented primary and secondary containment boxes allow interpreting the measured strain signals in terms of forces and pressures acting on the box. Making such calibration measurements offer a convenient alternative to FEM models for small and medium scale structures.

Linear Structural Response Models

The examples above suggest that both the structure as a whole, as well as structural details, may be converted into a force transducer when measuring the response to external loads. The fundamental assumption is that of a linear structural response in the elastic domain. Thus, the strain response at a set of sensor locations, \mathbf{E} , depend on a number of loads \mathbf{F} through a quadratic matrix of response factors \mathbf{K} as [2]:

$$\mathbf{E} = \mathbf{K} \mathbf{F}$$

Thus, the loads may be determined by inverting the response factor matrix \mathbf{K} :

$$\mathbf{F} = \mathbf{K}^{-1} \mathbf{E}$$

Typically, the designer of the sensor system will run FEM models or otherwise use his knowledge of the structure for optimal sensor placement. In this context, optimal sensor placement is a set of locations and orientations that maximizes the signal from the loads to be measured and minimizes any local effects and cross-sensitivity.

The response factors are determined by subjecting a FEM model of the structure to each of the loads to be determined, and recording the response at the sensor locations. In some cases, as for

the instrumented containment system boxes above, this characterization may be carried out by directly applying loads to the structure.

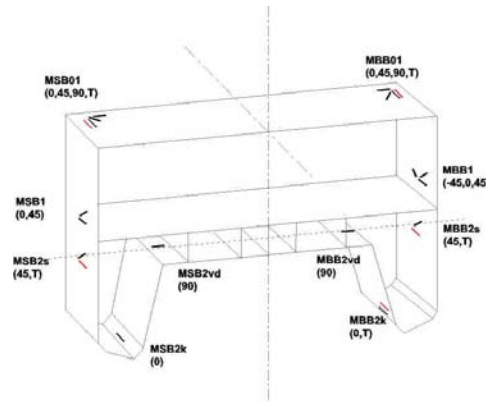

Figure 3: Mid section instrumented with 17 strain sensors to measure 6 global loads

As seen from Figure 3, the simplified case of estimating the vertical bending moment using one or two sensors at deck level is here generalized to using 17 strain sensors to estimate 6 global loads. The over-determination of the system, by using more sensors than the number of loads to be measured, further reduces the contribution of local effects which otherwise appears as noise.

It is important to note that the set of global loads to be estimated should be complete in the sense that all major contributors to the sensor signal are included.

Realtime load measurements

The load measurement technique was first installed and tested on the Royal Norwegian Navy pre-series Missile Fast Patrol Boat “KNM Skjold” in 1999 [2]. The vessel is designed to operate at speeds of up to 60 kn along the Norwegian North Sea coastline, meeting difficult seas and rapidly changing conditions.



Figure 4: KNM Skjold

Normally, operational limitations for such a vessel would be set based on a worst case scenario for a given sea state. This strategy relies on the subjective judgment of the sea state by the navigator. It is evident that such judgment is very difficult when operating at extreme speeds, at night and in rapidly changing conditions.

These problems have been tackled by installing a structural monitoring system on the series of Missile Fast Patrol Boats, measuring all relevant global loads and comparing them to allowable load and combination load limits. Thus, the navigator is provided with immediate and objective load level information for the vessel in any condition.

In addition to safer operation, the system allows for a fuller utilization of the structural strength. Traditional operation limits are normally set based on the worst case scenario for a given wave height range, while in this mode, the structure may always be operated at the safe side of the load limit regardless of conditions.

Deflection measurements

The linear response method is not limited to load measurements, but may also be used to estimate related parameters such as deflections and rotations of an elastic structure. This technique has been used for measuring the orientation of instrument packages such as sonar arrays, radars, and similar instruments where the exact orientation with respect to the vessel coordinate system is important.

Ice Load Monitoring

Operations in ice-infested waters provide another example of where a structural monitoring system provides essential information for the safe operations of a vessel. In August 2010 the tanker “Baltica” transited the Russian Northeast passage, completing the first such voyage for a high-tonnage tanker. Other transits are planned in the following months.

Safe transit through ice relies on the navigators accurate judgment of the loads the vessel are subjected to. Even in daylight, it is very difficult to tell from the bridge what the actual loads on the plating are and relate them to the local structural capacity. Unless permanent damage is suffered, the navigator has no way of learning whether his mode of operation is conservative, optimal, or high risk.

As larger vessels with lower ice classes are expected to transit through the Arctic regions, the challenges to safe operations are mounting. Ice loads are localized, and the larger the vessel is, the more the mass of the vessel is hiding the individual impacts.

Figure 7: Typical sensor arrangement on a frame. A frame section limited by two stringers are shown.

The typical sensor arrangement is shown in Figure 7. Shear stress measurement sensors are located at two levels, above (A2) and below (B2) the expected level of ice impact. Some frames were instrumented in a more comprehensive manner to evaluate the increased precision in measurements by using more than 4 filaments in the local area.

The fundamental postulate of this method is that the average force acting on a frame is proportional to the shear stress difference measured by the 4 sensor filaments

$$F_{\infty} \propto \Delta\tau$$

This assumption was verified by extensive non-linear FEM modeling of the frame structure, using an ensemble of all likely load cases. The FEM model results were also used to establish the structural capacity of the frames, and the corresponding proportionality factors for converting the measured shear differences into a structural utilization factor. A separate calibration and verification study was carried out by applying a known load to the frame by use of a hydraulic jack arrangement.

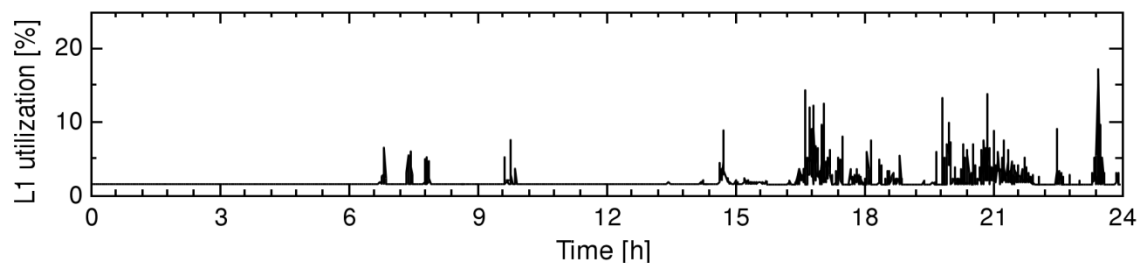

Figure 8: 24 hour trace showing frame utilization as a function of time

Two voyages were analyzed in detail. Figure 8 shows a 24 hour trace of frame utilization which corresponded well to the ice conditions met. The load magnitudes and durations agreed with expectations, and the load distribution followed the statistical models reasonably well.

Load Predictions

The examples above show that structural monitoring systems are well suited for converting a part of the structure, or the entire structure, into a transducer for measuring loads and displacements. Obviously, the recent loading history is readily available to the navigator. However, the time trace of the structural utilization presented in Figure 8 appears quite stochastic, and it may be difficult for the operator to judge whether the next load will exceed the critical threshold when operating close to structural limits. Thus, a forecast of the maximal likely load in the current conditions is of considerable value to the operator.

For the Ice Load Monitoring case, the distribution of the peak loads follow statistical models well. By analyzing the recent loading history in terms of the statistical model, we are able to alert the operator in advance when the probability of overloading exceeds a critical threshold. Also, we expect that load levels in nearby frames are correlated, so that even a limited instrumentation of representative frames may provide an accurate prediction of maximal structural utilization.

Similar distributions exists for extreme structural loads due to waves

Interaction with DP and similar systems

There are no HSM systems today that interact with DP systems that we are aware of. Routinely, HSM systems interact with onboard alarm systems, and provide operational guidance in real time.

To us, it is evident that structural monitoring systems may offer parameters that DP systems could use. One example is operating in ice conditions, where the systems may provide information on maximal ice impact forces and information pertinent to judging whether the current operations are safe with respect to hull integrity. Another is the operation of vessels with partially filled LNG tanks, where sloshing phenomena may threaten containment system integrity. In this case, changes to the vessel orientation may alleviate the situation.

Conclusions

Structural monitoring systems have, in the recent years, gained an increasing popularity in offshore applications. The typical installation is aimed at providing an objective measurement of hull loading history and fatigue damage, promoting the safe operation of the vessel. Recent developments have demonstrated that the systems may also be used for controlling critical local loads due to ice load or tank sloshing pressures.

References

1. DNV tanker update 2007:1
2. Jensen A. E.; Taby J.; Pran K.; Sagvolden G.; Wang G.; J Ship Res, Volume 45, Number 3, 2001, pp. 205-215
3. Leira B.; Børsheim L.; Eskeland Ø.; Amdahl J.; Proc IMechE, Vol 223 Part M, No 4, 2009, pp. 529-540
4. Pran K., Le Breton A., Sagvolden G., Espeland Ø., Mejlaender-Larsen M.; Proc IWSHM 2009 Vol 1, 2009, pp. 625-632