



DYNAMIC POSITIONING CONFERENCE

October 13-14, 2009

Power

Power Management Systems for Offshore Vessels

Lew Weingarth

Transocean, Houston, Texas, USA

Scott Manson, Saurabh Shah, and Kamal Garg

Schweitzer Engineering Laboratories, Inc., Pullman, Washington, USA

Abstract

Large offshore mobile drilling vessels contain onboard power systems with load demands as high as 50 MW. The load demand is supported by six or more electrical generators running in parallel on a single bus. These generators are driven by a variety of prime movers; the most common ones are two- and four-cycle diesel engines.

Common modes of faults may result in a complete blackout of the power system. On DP (dynamic positioning) drilling rigs, undesirable electrical system outages can result in revenue losses of millions of dollars, increased risk of an environmental incident, and damage to public opinion of the industry. This makes the electrical power system protection and control package critically important for DP vessels.

This paper first explains some of the protection failures currently experienced on these vessels, including failure or misoperation of generator exciters and governors, islanding of defective generators, slow fault detection, and clearing of wrong machinery. The criticality of designing complete systems for simplicity, robustness, maintainability, testability, local support, ease of commissioning, longevity, and availability is also explained.

This paper concludes with the discussion of a new paradigm for advanced prevention of blackouts, the keystone of which is a sophisticated generator protection and control system specifically designed for the needs of DP rigs. This includes an overview of the generator protection system, communications architectures, hardware designs, and visualization system. The new paradigm offers many previously unachievable technological enhancements, such as continuous harmonic analysis, advanced visualization, high-speed protection, standard IEC 61131 programming, and modern communications protocols.

DP3 class notation requirements address reliability indirectly in that two components are more reliable than one of the same component. However, one component with a mean time between failures (MTBF) of 20 years provides more reliable service than two components with an MTBF of 6 months each. Redundancy and reliability are not synonymous. Where possible, the solution presented in this paper justifies reliability claims with actual statistical data. Redundancy alone is not assumed to achieve goals that require statistical data to justify.

Index Terms—Offshore vessel, power management system, PMS, load shedding, common failure modes, harmonic analysis, advanced generator protection, IEC 61850, GOOSE, exciter, governor, black start, synchrophasor, arc flash, automatic synchronizer, decoupling, real-time digital simulations.

I. Background

Transocean, the world’s largest offshore drilling contractor, has a long history of operating DP (dynamic positioning) rigs,

dating back to the first DP drillship and semisubmersible units. During this time, Transocean has accumulated 325 rig years of understanding of power plant reliability. As a result, in major deep-water provinces today, the company has rigs with power plants that operate isochronously with load sharing and electronic protective relays, in droop mode with power management oversight, in droop mode with local (per-unit) protection, and many variations in between.

In addition to helping improve DP reliability working with the IMCA (International Marine Contractors Association), Transocean continues to collaborate with maritime equipment manufacturers and to train personnel to better prevent and mitigate power plant problems.

II. Typical System Overview

A. Electrical System

Fig. 1 shows an example of a power system one-line diagram for a DP ultra-deep-water drilling rig. In this example, the Transocean vessel has six main generators rated at 3.6 MW each, eight bow/stern thrusters rated at 2.3 MW each, and variable-speed drives to operate the system. There are two main 11 kV buses connected via the bus-tie breakers, which are normally open. Grounding transformers are provided at both of the main 11 kV buses. Each 11 kV main bus supplies power to a 480 V bus for vessel service and a 600 V bus for drilling. The 480 V supply is also stepped down to 208/120 V for small power and lighting loads.

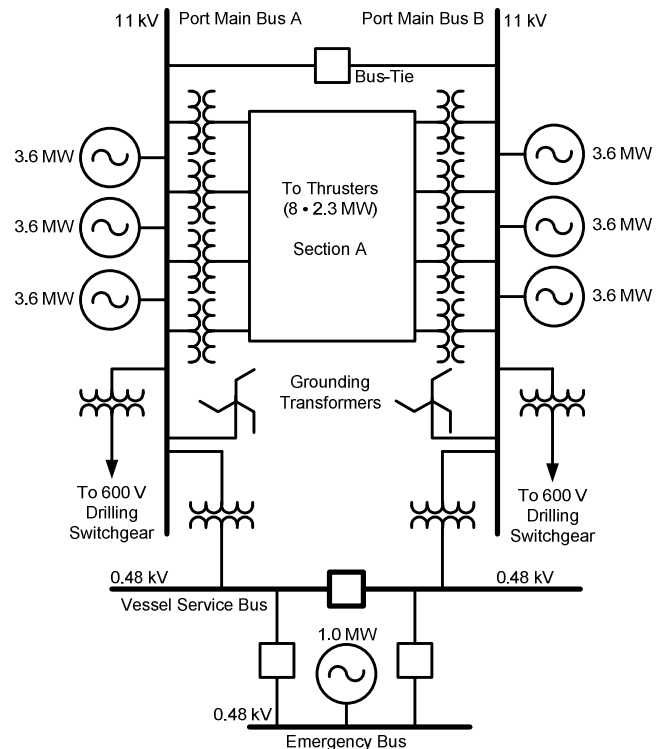

Fig. 1. Simplified Electrical System

The thrusters have dual feeds that can draw power from both buses. The 11 kV bus is a radial bus with bus-tie breaker and is fully insulated to provide protection against short circuits.

B. System Description

During normal and dynamic positioning operations, the 11 kV main switchboard bus-tie breakers can be open or closed. The power plant includes separation, requiring equipment redundancy to meet DP3 class notation. DP3 is the highest class of dynamic positioning for vessels requiring high levels of redundancy and separation to ensure the system can withstand the impact of fire and flood. As such, the plant is required to survive the loss of any active component in any compartment. Class redundancy requirements are primarily focused on maintaining station service. Class requirements do not address the larger issue of keeping the vessel drilling or maintaining maximum revenue. Maintaining maximum revenue requires a protection and management philosophy that significantly exceeds the redundancy requirements of meeting DP3 class notation. Operations and operability must be addressed as well as equipment protection.

Fig. 2 shows the configuration of typical thrusters, which are shown as a block in Fig. 1.

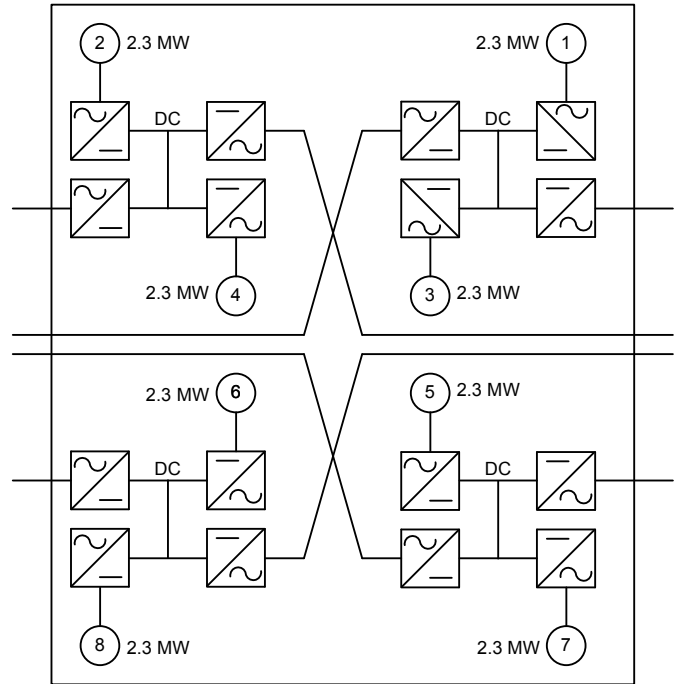

Fig. 2. Thrusters—Detail of Section A From Fig. 1

III. New Solution

Fig. 3 shows the conceptual block diagram for a future power management system (PMS) protection scheme. Generator protection is included in the local protection block. The local protection block also communicates with the generator control block. Local protection devices communicate via direct fiber relay-to-relay or using

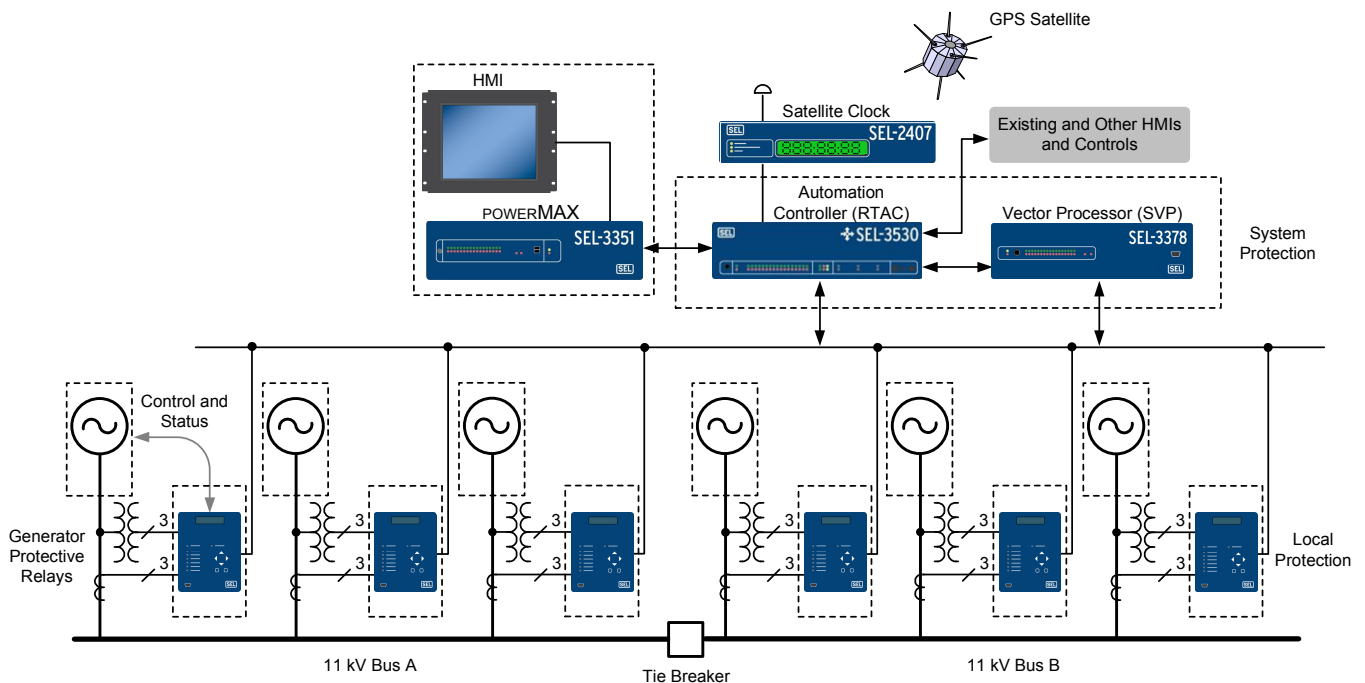

Fig. 3. Future Solution for PMS

IEC 61850 protocol using Ethernet in the system protection block. System protection is the hub of all the decisions for PMS control and data exchange. It processes all the relevant information from local protection and provides control and decisions for the PMS. The proposed future solution also provides decisions, like controls for black start, manual override, and load shedding [1]. The solution includes an HMI (human-machine interface) screen for system overview and control.

A. Local Protection

The local protection block includes the generator protective relays. For the existing scheme, only one relay per generator is installed. If redundancy is desired, more than one generator protective relay can be installed per generator [2][3]. The following protection is proposed to be programmed for generator protection:

- Excess or reverse power
- Reactive power
- Differential
- Loss of excitation
- Out of step
- RTD (resistance temperature detector) protection
- Trip-coil monitoring
- Current/voltage unbalance
- Phase reversal
- Negative sequence
- Under-/overvoltage
- Under-/overfrequency

B. System Protection and the Power Management System

System protection provides the function of a data concentrator and includes all the control for the PMS. Based on the overall DP system protection review, any additional protection, such as feeder, bus, motor, and transformer protection, is included as part of system protection. The PMS also provides the following functions:

- Load-dependent start/stop
- Generator running order selection
- Load shedding
- Heavy-consumer start block
- Blackout start and recovery
- Diesel engine control

The PMS provides the control for generator start/stop based on the loads and priority of the generator to start the assigned units in the sequence as required. Local generation can support the 100 percent load during normal operation; however, during the outage of some units, a load-shedding scheme is enabled. Algorithms must be designed (i.e., priority loads to shed) into the system in order to react properly. The PMS provides the control and start/stop of all generators.

The system uses low-impedance bus protection (e.g., SEL-487B Bus Differential and Breaker Failure Relay).

However, the protection can be designed for any of the following functions:

- Blocking
- Low impedance
- High impedance

Low-impedance bus protection was selected for this project because the appropriate protection operates in less than 1 cycle. One low-impedance SEL-487B Relay provides the bus protection for six inputs. So each solution provides bus protection that accommodates the necessary number of sources and clears faults in 1 millisecond relay operating time. The total clearing time is this relay’s operating time plus the breaker operating time and is therefore shortened with rapid relay operating time. Bus faults are rare, but when faults are not detected and cleared quickly, millions of dollars in production losses may result. There is a direct correlation between faster relay operating time and a reduction in production losses.

Separate bus protection for each 11 kV main bus improves the system availability by islanding the faulted bus only.

C. Mean Time Between Failures and Redundancy

Using unavailability for each component of a system, fault trees are used to predict the overall system unavailability. MTTR is the mean time to detect and repair a failure. Schweitzer Engineering Laboratories, Inc. (SEL) assumes a worst-case MTTR number of 4 hours for the components in the proposed system. MTTF is the mean time to fail. SEL measures the MTTF of all their in-service products. MTBF is the mean time between failures, expressed as $MTBF = MTTR + MTTF$. Table I documents the failure rates. A review of the data shows that the likelihood of hardware component failure is very low.

TABLE I
MTBF FOR SEL PRODUCTS

Component	Observed MTBF (years)	Unavailability (multiply by 10 ⁻⁶)
SEL POWERMAX Controllers and FEP (front-end processor)	50	9.1
SEL-2411 Programmable Automation Controller	150	3.0
SEL Relays	300+	1.5
Ethernet Switch	50	9.1

Generator protection philosophies that operate entirely at the generator level cannot detect external faults such as main bus failure. Generator protection philosophies that operate at a higher, supervisory level may not detect individual generator faults or may not be able to determine the faulty generator in the case of “common-mode faults.” Combined systems using local and supervisory protection offer more comprehensive protection but may not be optimal because of the widely different scan rates of the two systems. However, a system

designed upon synchrophasor data obtains the sampled data every cycle and generates control signals within 2 to 3 cycles. Considering the slower response time of exciters and governor, this proposed system design is adequate.

D. Communication and Integration to the Power Management System

Fig. 3 shows the complete system with communications and PMS integration. The proposal uses fiber optics and MIRRORED BITS® communications to communicate between various components. These communications are self-monitored. The user is automatically notified of any communications failure. Alternatively, the system can be designed using the IEC 61850 protocol and GOOSE messaging. As an option, systems can be designed using both IEC 61850 and MIRRORED BITS communications. The system protection block collects all the information from the local protection block, and the correct sample rate is selected based on proper testing and design. It is anticipated that synchrophasor data will be fed directly to a synchrophasor vector processor for time alignment and logic processing. Other relevant information is sent directly to a communications processor. Additionally, the proposed system is capable of providing a secure communications gateway via standard protocols such as Modbus®, DNP3, and others.

E. Engineering Diagnostics and Analysis Tools

The proposed solution includes various inbuilt tools for system analysis and self-diagnostics. All the relays and protection functions are self-monitoring and record any system discrepancy. Operators receive visual alarms. Using the PMS, the HMI continuously displays the operating parameters and custom screens with alarm details. A separate screen is developed for each system component. The proposed system is programmed to call and send important information to key personnel for critical alarms.

The proposed PMS solution will automatically archive sequence of events (SOE) records from all the relays. SOE records generate CSV (comma-separated value) files with accurate satellite clock time stamps. Fig. 4 shows an example of SOE records and lists the digital signals and time stamps. In addition, ACSELERATOR Report Server® SEL-5040 Software archives event report (ER) oscillography for both analog and digital signals of each major event. The ER is archived in the PMS. This information can be used for the analysis of any system operation. Fig. 5 displays an example ER.

GPIC.csv - Sequence of Events Record Viewer

Time	Equipment	Description	State	Device	Element
10/09/2007 08:05:31.822		51A POWER UP	ASSERT	SEL451A	
10/09/2007 08:05:31.822		CB2 LOCKOUT	ASSERT	SEL451A	
10/09/2007 08:05:31.822		CB3 LOCKOUT	ASSERT	SEL451A	
10/09/2007 08:05:31.822		UV TRIP	ASSERT	SEL451A	
10/09/2007 08:05:31.822		LIF TRIP	ASSERT	SEL451A	
10/09/2007 08:05:31.822		51A RELAY ABNORMAL	ASSERT	SEL451A	
10/09/2007 08:05:31.822		DFDT ALARM	ASSERT	SEL451A	
10/09/2007 08:05:31.822		PH ANG ALARM	ASSERT	SEL451A	
10/09/2007 08:05:31.822		UV ALARM	ASSERT	SEL451A	
10/09/2007 08:05:31.822		LIF ALARM	ASSERT	SEL451A	

Fig. 4. Example Sequence of Events

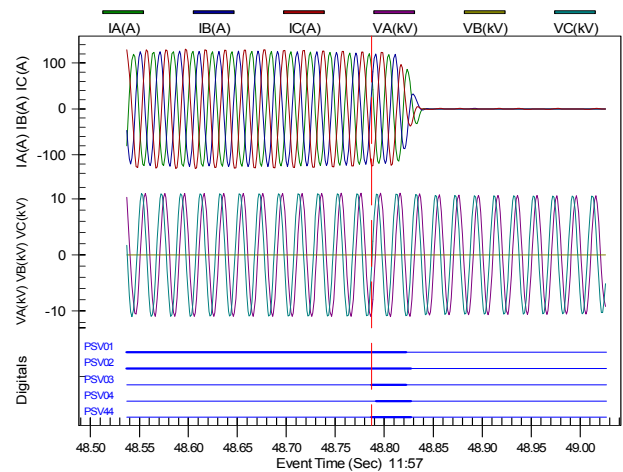

Fig. 5. Example Event Report

F. Additional Features

In addition to the functions of the PMS and generator protection, the proposed scheme includes the following features:

- Synchrophasors
- Flexible synchronizer
- Arc-flash protection

1) Synchrophasor

A definition of real-time (synchronized) phasors is provided in the IEEE Standard 1344-1995. Applying synchrophasors improves performance for these critical applications. As stated earlier, each machine state is based on highly accurate GPS (Global Positioning System) satellite clock signals and synchrophasor data [4]. Critically important signals (i.e., voltage, speed, MW, and MVAR) are received from each generator. This information is used to design the overall generator protection. The sampling rate of 60 messages per second provides this information every cycle.

Fig. 6 shows the phasor measurement of multiple machines. The logical comparison of the synchrophasor variables is performed using system protection. With this functionality, the system performs logic calculations and generate control signals. Using modal analysis (included in system protection), it is also possible to calculate the resonance and oscillation frequencies. This information will be used for the advanced generator protection design for this project. Fig. 7 shows the frequency spectrum using modal analysis.

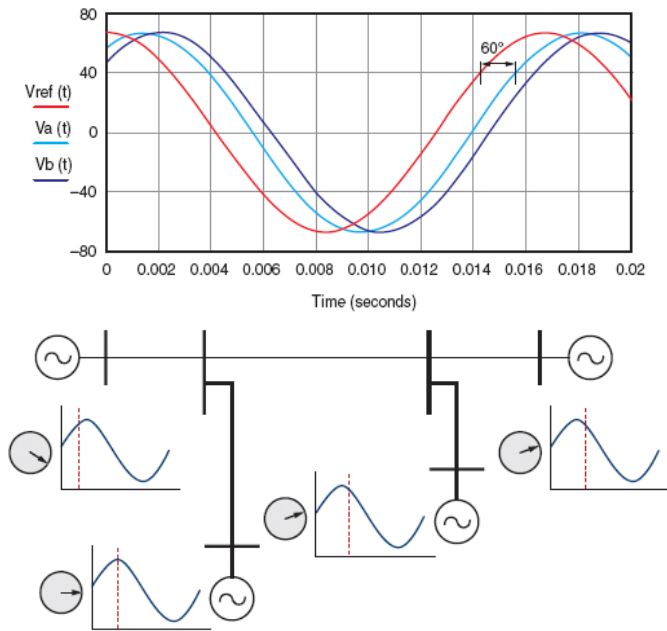

Fig. 6. Synchrophasor Measurement

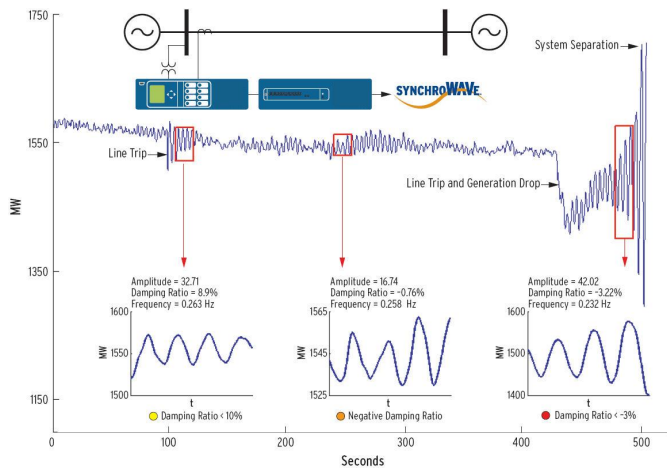

Fig. 7. Modal Analysis Using Synchrophasors

2) Flexible Synchronizer

The proposed solution provides automatic synchronization. Fig. 8 shows a sample screen of the synchroscope. This figure shows two voltages, phase angles, and slip frequency. Per system requirements, multiple settings for synchronization can be enabled. For some operating conditions, it is also acceptable to enable synchronization even with large slip and phase shift values. Using the synchrophasor visualization aids, it is possible to design the display screen and use this information for automatic synchronization. If desired, custom screens are created to meet system and project requirements.

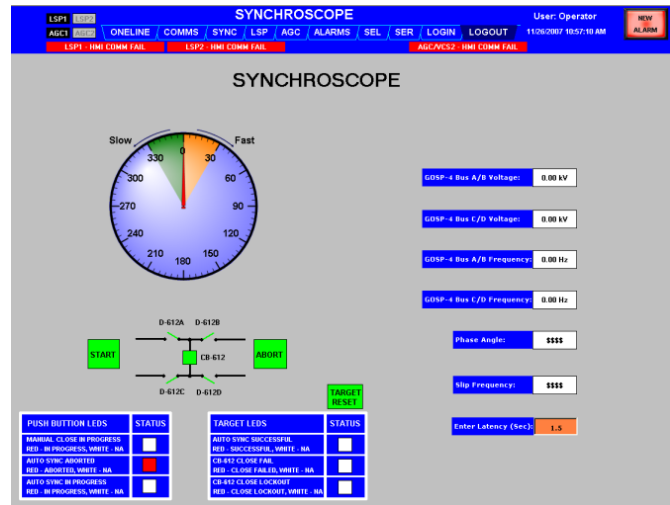

Fig. 8. Automatic Synchronizer

3) Arc-Flash Hazard

Arc-flash protection is very important for the personnel working on the DP vessel. Fast, reliable operation of an arc-flash protective relay improves safety and reliability. The proposed solution also provides feeder and arc-flash protection. Using advanced technology, faults can be detected in 2 to 3 milliseconds, limiting the arc-flash damage. The proposed relay logic uses both light and current to detect the fault. Peak detector logic is enabled to quickly determine the current without losing accuracy, because filtering requirements delay the sensing of current. A detailed arc-flash study, appropriate PPE (personal protective equipment) selection, system design, field commissioning, and product support are included as part of this project.

Fig. 9 shows the SEL solution for arc-flash detection. Up to four sensors, point and loop, are installed in this solution, and all the switchgear sections are protected using selective tripping. Fig. 10 shows that this protection operates in about 2 to 3 milliseconds. In addition to relay operation time, interrupting devices, such as breaker operation time, will also impact the overall arc-flash category. As part of an arc-flash study, possible ways to reduce the arc-flash category will be determined and appropriate warning labels will be posted at various switchgear locations to instruct people to use appropriate PPE. This will define the working boundary for qualified personnel.

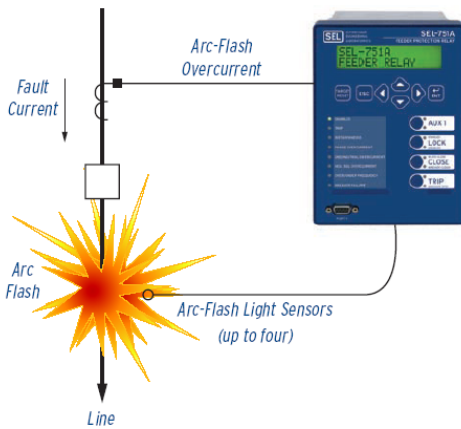

Fig. 9. High-Speed Arc-Flash Detection

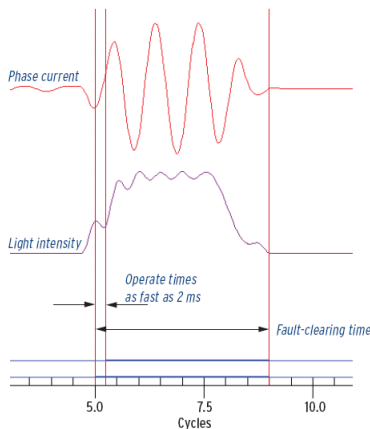

Fig. 10. Arc-Flash Operation Times

G. Common-Mode Faults

Common modes of failures are defined as faults that affect overall system operation and cause multiple redundant elements to react adversely. For normal operating conditions, all the generators operate in parallel droop mode. In case of a fault on one generator exciter/governor or any other common-mode fault, it is desirable to properly detect and isolate only the faulty machine/component from the system as soon as possible [5]. It is also required to evaluate the response time of controls (e.g., exciter/governor controls) before making decisions regarding any system isolation or islanding.

Otherwise, undesirable system operation may result in additional faults or failures.

Common modes of faults are classified into the following four categories:

- F1 – faults based on governors
- F2 – faults based on fuel/actuator
- F3 – faults based on exciters
- F4 – miscellaneous faults

Table II shows common faults and possible solutions. Each main type of fault and PMS operation during the fault is discussed later.

TABLE II
COMMON-MODE FAULTS AND SOLUTIONS

Fault No.	Description	Equipment
F1	Out of Droop Band	Governor
F2A	Actuator Current Low— Actuator Output Low	Actuator
F2B	Rack Not Tracking Actuator— Fuel Rack Problem	Actuator
F2C	kW Not Tracking Fuel Rack— Fuel Problem	Actuator
F2D	Fuel Rack Hunting— Generator Hunting	Actuator
F3A	Overexcitation/Underexcitation	Exciter
F3B	Unstable Voltage Control— Hunting	Exciter
F3C	Loss of Exciter Current	Exciter
F4A	Miscellaneous Faults	Miscellaneous
F4B	Breaker Status Fail, kW > 0 and Circuit Breaker Indication Open	Miscellaneous
F4C	Breaker Status Close, f = 0, Generator Running	Miscellaneous

When droop and no-load speed are set the same on all the diesel engines, units that are electrically or mechanically tied together will inherently share the load equally. Consistent droop results in a predictable speed for a given load on a generator based on a droop curve, the health of the connected diesel, and the speed control system. A deviation from this curve beyond an acceptable window is indicative of an unhealthy status in the engine (unable to deliver the required kW) or a problem with the speed control system or its control system tuning parameters. These symptoms occur if there is a loss of engine power, such as a sticky injector, fuel pump failure, dirty fuel filter, incorrectly set ballhead governor, or limited fuel rack linkage movement. The power generated is below the level expected for the running speed as determined from the established normal speed-load curve for this engine. Hence, for the bus frequency of 60 Hz, the engine operates at less than 50 percent of full load. The other engines online are generating more power than they would have to if all generators were sharing equally; therefore, the speed is

slightly lower than what would be expected for normal operation with that load.

Fig. 11 and Fig. 12 show the operation during the governor faults. Fig. 11 shows the slope and 3 percent droop characteristics for the generators operating in parallel. Curve A is selected if generators are operating normally around the 100 percent load. Curve B is selected if the unit normally operates around 50 percent load. For this analysis, Curve B is selected when normal operating load is 50 percent. The system is operating at 50 percent generator load with 60 Hz frequency. If the load is increased beyond 50 percent, this machine will share more load, but the system operating frequency goes down on the 3 percent slope. The operating frequency will be 59.1 Hz for the machine on Curve B if the load is increased to 100 percent.

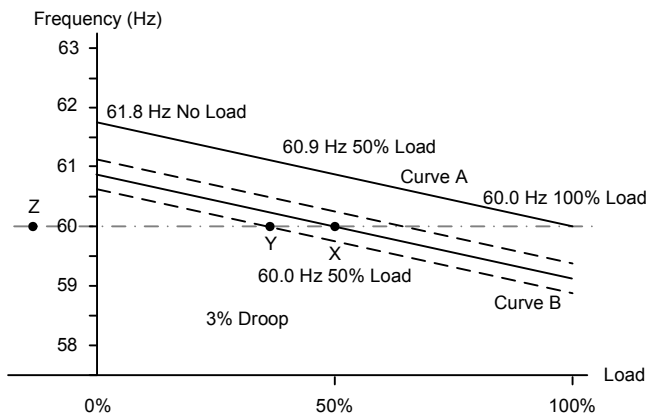

Fig. 11. Low kW and Droop Mode

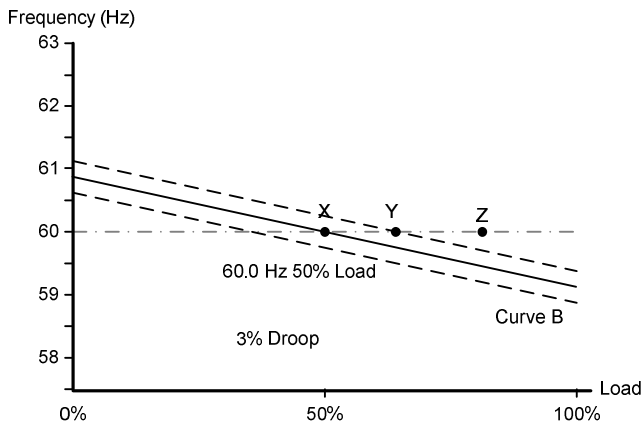

Fig. 12. High kW and Droop Mode

For a low kW fault (F1) when one machine is generating, the Curve B generator operating point moves from X to Y (see Fig. 11). For the operating point within the generator band, the control signal is only initiated for the faulty generator. However, if this generator goes outside the allowable band, system protection and the PMS will start to island the faulty generator. Now system load will be shared by the rest of the machines. System frequency drops, and PMS generates another control signal to correct the system frequency.

Fig. 13 and Fig. 14 document the typical exciter and governor controls connected with typical generator protective relays. These figures also show the appropriate control signals connected between the generators and local protection system. Hence, based upon the operating conditions, the PMS generates control signals to operate and control the overall system, including loads and generation.

A high kW fault may result from speed control feedback loss or actuator signal loss for a particular defective generator. This event results in producing more power than scheduled from this defective generator. This type of fault results in the remaining generators running lightly loaded. Fig. 12 illustrates that if the operating conditions for a generator change from X to Y, a control signal initiates for this generator. For this condition, system frequency increases. If this generator does not respond to the controls and drifts further to point Z, a trip signal is initiated. Similar to the system condition for low kW conditions, the PMS generates a control signal to correct the system frequency. This fault is also indicated as an F1 fault in Table II.

The generator voltage control system will also be running in droop mode. When droop and no-load voltages are set the same on all the generators, these units will inherently share the kVAR equally. However, voltage control is more complex because it depends on the exciter controls. Exciter control can be initiated based on the system conditions, allowing system protection to monitor these operating conditions and provide information to the PMS. Because of faulty AVR electronics, low settings, or unstable voltage control, hunting is sensed via local protection (F3 faults in the Table II). When a parallel generator is hunting, it periodically takes or sheds reactive power, resulting in hunting in the overall system. System protection identifies the generator with the faulty exciter and alarms the user to take corrective action. In the case of exciter loss of the current feedback because of a faulty exciter, the system generates another alarm. Hence, appropriate action is programmed based on the severity and acceptable operating conditions.

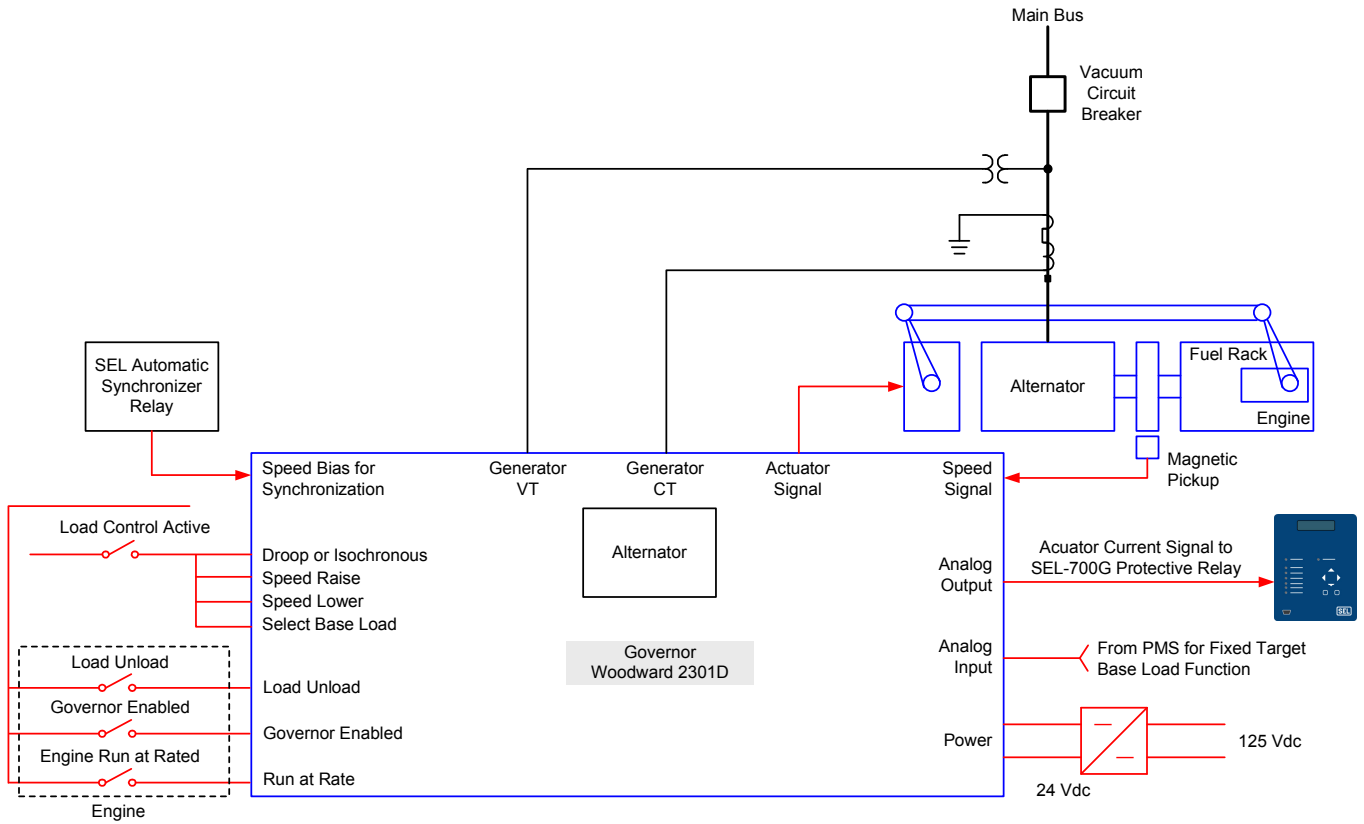

Fig. 13. Typical Woodward Governor and Controls

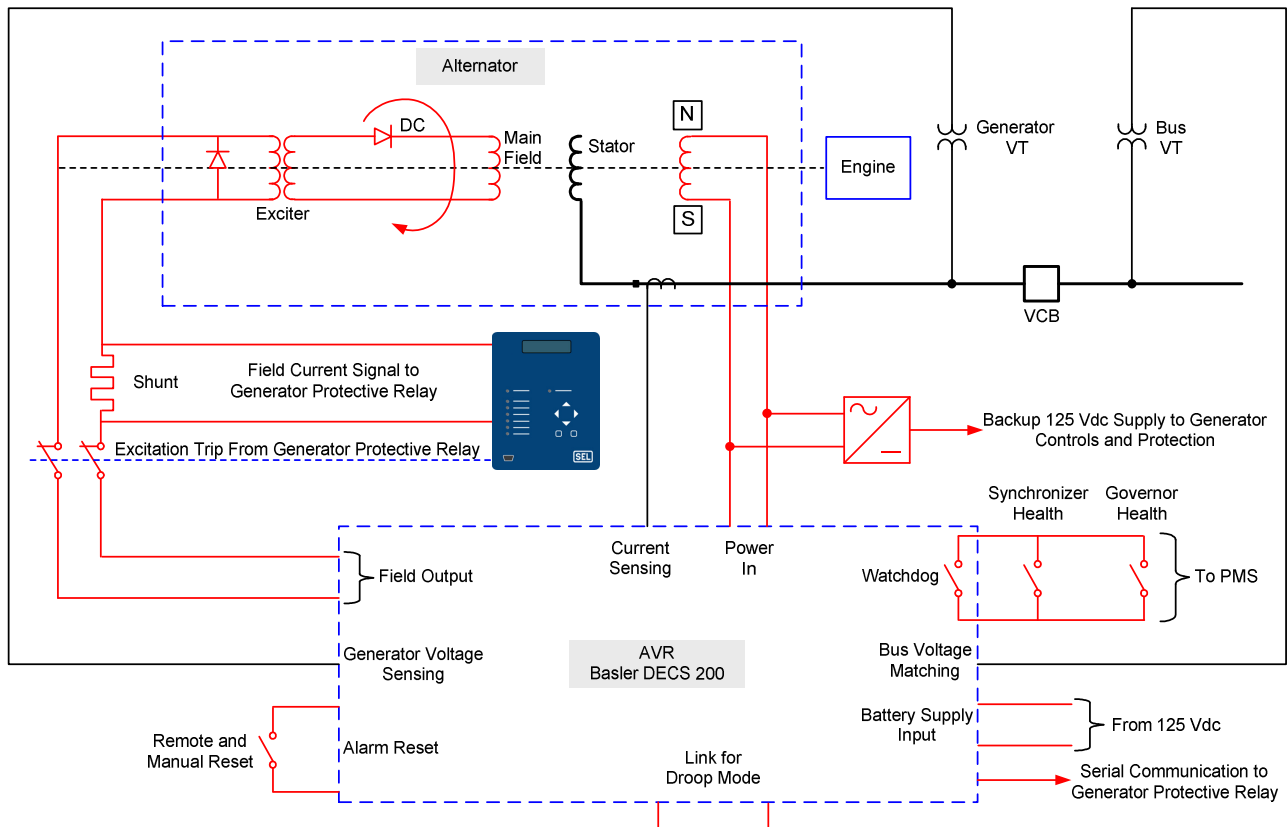

Fig. 14. Typical AVR (Automatic Voltage Regulator) and Exciter Controls

Some faults result because of the fuel rack position and actuator current (F2 faults in Table II). For this type of fault, when actuator current does not track the rack position, an alarm is generated. In the case of a generator fuel problem (damage to fuel line or fuel quality), generator output will not follow the generator fuel rack. Alarms are generated for the predetermined time, and subsequently, the unit is tripped because of the F1 fault discussed previously. Fuel rack hunting may be caused by a number of problems, including dead bands in linkages, faulty speed governor electronics, faulty engine generator shaft coupling, etc. The system protection block analyzes operating conditions and generates an alarm for the appropriate generator. The algorithm requires monitoring the generator parameters, including the fuel rack position for each generator.

For system fault conditions such as breaker status open and generator kW loss, an alarm is generated (F4 faults in Table II). This fault condition indicates that the system has lost the breaker status. For the system fault of breaker status close but frequency indication zero, an alarm is generated for the defective generator with some time delay. During this time, this generator is assumed to be operating properly, and, if system disturbance continues beyond a predetermined time, the system protection islands the faulty generator, similar to an F1 fault. For miscellaneous system faults, such as any protective relay failure, the breaker contact failure to operate or any abnormal system condition is indicated as an alarm.

IV. Other Critical Issues

A. Design Verification

The PMS is designed and validated in the laboratory before it is deployed in the field. Such critical systems need to have the controllers and associated equipment tested during factory acceptance testing. These critical systems need to have their controls validated and tested in a real-time simulation environment. Using this type of validation and testing accurately models governors, turbines, exciters, rotating machinery inertia, load and electrical characteristics, electrical component impedances, and magnetic saturation of electrical components [6][7]. The tests verify several system parameters, such as the voltage change rate with MVAR ($\delta V/\delta \text{MVAR}$) and the frequency change rate with MW ($\delta F/\delta \text{MW}$). This test also coordinate and verify underfrequency backup systems, contingency load-shedding systems, load makeup ratios, and total system inertia constant (H). The verification of these parameters is crucial to the proper operation and coordination of the modern PMS.

Properly designed, validated, and tested systems in the lab environment lead to less time spent on-site and commissioning the overall system. It also allows the PMS to be deployed quickly and safely. A poorly designed and untested PMS costs the end user more downtime and money, in some cases millions of dollars. From a budget perspective,

the end user typically recoups the cost of the PMS with the reduced downtime of one outage.

B. Model Power System Test and Example

The model power system (MPS) testing laboratory is the proposed site for complete testing of SEL systems using the Real Time Digital Simulator (RTDS[®]). RTDS equipment allows dynamic modeling of the customer's power system with a simulated small time step to test all closed-loop controls and protection systems.

Electrical transient studies use simplified positive-, negative-, and zero-sequence models of power system impedances and sources to calculate the short-circuit currents in a power system. These models are not acceptable for any form of dynamic stability study because they do not model system inertia or governor response times. This form of modeling is appropriate for protective relay coordination; however, for the design of PMS protection, a study that requires detailed system dynamics is required. Hence, the RTDS is an appropriate tool for the design verification of this project.

Fig. 15 shows an example system with two machines and one swing machine (external utility). For this example system, the GSU (generator step-up) transformer, step-down transformers, loads, generators, exciters, and governors are modeled in detail. All the major rotating and static loads are modeled per the information provided. Based on tests for the load flow, short circuit, motor start, and exciter governor, the model is verified for accuracy. Because the accuracy of the design and settings are based upon this verification, correctly modeling the system is critical. The system performance will also be verified during field installation. This successful test method will be applied to the DP system shown in Fig. 1, in which the RTDS model will use six machines with detailed dynamic models.

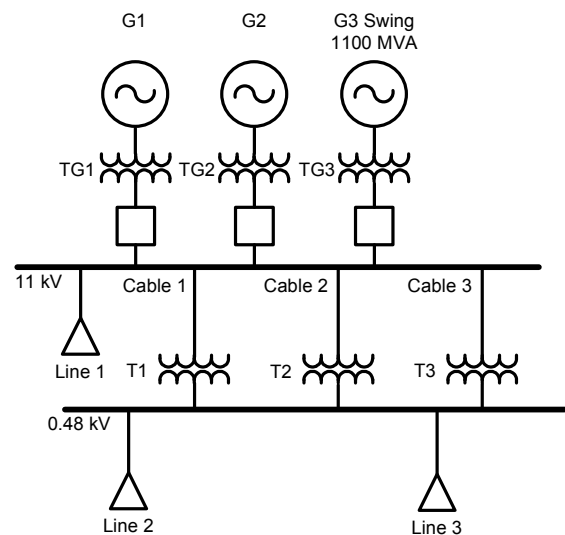

Fig. 15. Example One-Line Model in the RTDS

Fig. 16 shows the RTDS connection to a test rack. All the power system components are located in the RTDS rack, and information is exchanged between the RTDS rack and test rack for this system. Fig. 17 shows the generator parameters observed for the step-load test. This information will be used to benchmark the exciter and governor performance.

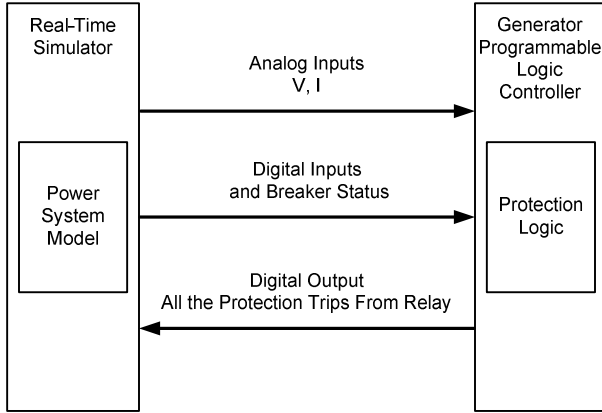

Fig. 16. RTDS and Test Model Connection

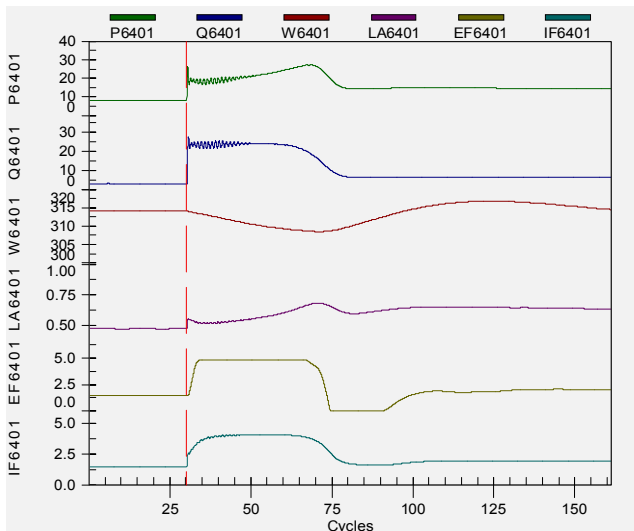

Fig. 17. Results of Step-Load Test Using an RTDS Modeling an Example System

The RTDS testing verifies the system design, settings for the protection, and overall system performance. Multiple faults and system problems are created and tested in a closed-loop system, evaluating the system performance even before the PMS is installed on-site. In addition, the results of on-site testing are used to revalidate the system design. Once the standard DP system model is built, it is easily used for future system expansion and design variation. SEL has used this tool for various projects with complicated system designs where settings are dependent on the system design parameters. Without detailed testing, selecting proper protection is not possible.

C. *Off-the-Shelf and Expandable Projects*

As mentioned earlier, the proposed system configuration is shown in Fig. 3. For this example project, only six generators are installed; however, this system is easily expanded for vessels designed with more than six generators. As part of this project, the overall protection scheme will also be reviewed. The scheme will be designed considering system contingencies and future growth. Using the proposed scheme as a template for future design reduces engineering costs. Once the system is designed and tested for one vessel, the same design is easily applied to other vessels. The cost of training, maintenance, and system operation is also reduced because of the standard system design.

D. *Local Support, Documentation, and Training*

Detailed documentation and local support is best provided at the customer location. Deep-water drilling platforms are located all over the world, so support and training for these critical projects are required “as needed” and “when needed.” Transocean found that a global presence of the support company (like that offered by SEL) is very important to the acceptance and success of the project.

V. **Conclusion**

The proposed PMS provides a highly reliable system design, using the solution shown in Fig. 3. The local protection block provides the generator protection; the system protection block includes all the system design components and programming for decision and control. This solution provides cutting-edge protection functions for generators using synchrophasor technology and optional IEC 61850 protocol. In addition, the solution includes a PMS (SEL POWERMAX), arc-flash protection, and automatic synchronizer. This solution is very robust, easily expandable, and self-diagnostic. It provides automatic archiving of SOE and ER. Using advanced technology and tools, a very reliable PMS is designed and implemented.

PMS design and deployment should include studies such as load flow, short circuit, arc flash, relay coordination, black start, and stability for proper system design. Detailed studies, factory acceptance tests, reports, and logic diagrams should address all possible contingencies and operating conditions, including the comparison with manufacturer provided information and on-site testing results. This testing facilitates system operation verification, because without proper documentation and analysis tools, accurate analysis of any system disturbance or operation is not possible. Documentation is very important for troubleshooting and analysis of any trip or misoperation. For this type of critical project, the operation staff relies on training and support to understand and operate their cutting edge power management system.

VI. References

- [1] D. Miller, R. Schloss, S. Manson, S. Raghupathula, and T. Maier, "PacifiCorp's Jim Bridger RAS: A Dual Triple Modular Redundant Case Study," proceedings of the 11th Annual Western Power Delivery Automation Conference, Spokane, WA, April 2009.
- [2] M. Oens and C. Lange, "Improvements in Feeder Protection—Providing a Primary and Backup Relay System Utilizing One Relay Per Feeder," proceedings of the 33rd Annual Western Protective Relay Conference, Spokane, WA, October 2006.
- [3] B. Cho, H. Kim, M. Almulla, and N. Seeley, "The Application of a Redundant Load-Shedding System for Islanded Power Plants," proceedings of the 35th Annual Western Protective Relay Conference, Spokane, WA, October 2008.
- [4] E. O. Schweitzer, III, D. Whitehead, A. Guzmán, Y. Gong, and M. Donolo, "Advanced Real-Time Synchrophasor Applications," proceedings of the 35th Annual Western Protective Relay Conference, Spokane, WA, October 2008.
- [5] D. A. Tziouvaras and D. Hou, "Out-of-Step Protection Fundamentals and Advancements," proceedings of the 56th Annual Conference for Protective Relay Engineers, College Station, TX, April 2003.
- [6] A. Al-Mulla, K. Garg, S. Manson, and A. El-Hamaky, "Case Study: A Dual-Primary Redundant Automatic Decoupling System for a Critical Petrochemical Process" proceedings of the 2009 PCIC Europe Technical Conference, Barcelona, Spain, May 2009.
- [7] J. Kumm, E. O. Schweitzer, III, and Daqing Hou, "Assessing the Effectiveness of Self-Tests and Other Monitoring Means in Protective Relays," proceedings of the 21st Annual Western Protective Relay Conference, Spokane, WA, October 1994.

VII. Biographies

Lew Weingarth received his BSEE from the University of Missouri-Rolla with honors in 1981, after which he worked for Southeastern Drilling Company as an engineer trainee. He is working toward an MBA. Until 2001, Lew worked in the offshore deep-water drilling industry, primarily on DP vessels. He then became an international consultant on DP and power management systems, working for oil companies and drilling contractors. In 2004, Lew accepted a position with Transocean as a DP superintendent for the purpose of assembling a discipline dedicated to eliminating DP and power system downtime by improving the reliability of control systems, power plants, and operations onboard modern DP rigs.

Scott Manson is a supervising engineer in the engineering services division of Schweitzer Engineering Laboratories, Inc. (SEL). He received his MSEE from the University of Wisconsin–Madison and BSEE from Washington State University. Scott worked at 3M Corporation as a control system engineer for six years prior to joining SEL in 2002. Scott has experience in designing and implementing control systems for electrical utility customers, high-speed web lines, multiaxis motion control systems, and precision machine tools. Scott is a licensed Professional Engineer in four U.S. states.

Saurabh Shah is a branch manager in the engineering services division of Schweitzer Engineering Laboratories, Inc. (SEL). He received his BS in 1995 and AS in computer systems in 1991 from Lewis-Clark State College. He has a broad range of experience in the field of power system operations, protection, automation, and integrated systems. He has served nearly 19 years at SEL, where he worked in relay testing, sales, business development, and engineering project management before becoming branch manager of engineering services.

Kamal Garg is a project engineer in the engineering services division of Schweitzer Engineering Laboratories, Inc. (SEL). He received his MSEE from Florida International University and India Institute of Technology, Roorkee, India, and a BSEE from Kamal Nehru Institute of Technology, Avadh University, India. Kamal worked for Power Grid Corporation of India Ltd. for about seven years and Black & Veatch for about five years at various positions before joining SEL in January 2006. Kamal has experience in protection system design, system planning, substation design, operation, testing, and maintenance. Kamal is a licensed Professional Engineer in five U.S. states.