

POWER

Advanced Failure Detection and Handling in Power Management System

Petter F. Johannessen

Eirik Mathiesen

Kongsberg Maritime AS, Kongsberg, Norway

October 13 -14, 2009



Power

Advanced failure detection and handling in Power Management System

Petter F. Johannessen, Eirik Mathiesen
Kongsberg Maritime AS, Kongsberg, NORWAY

October 13-14, 2009

- Introduction
- Advanced Generator Supervisor (AGS)
- Results from full scale tests.

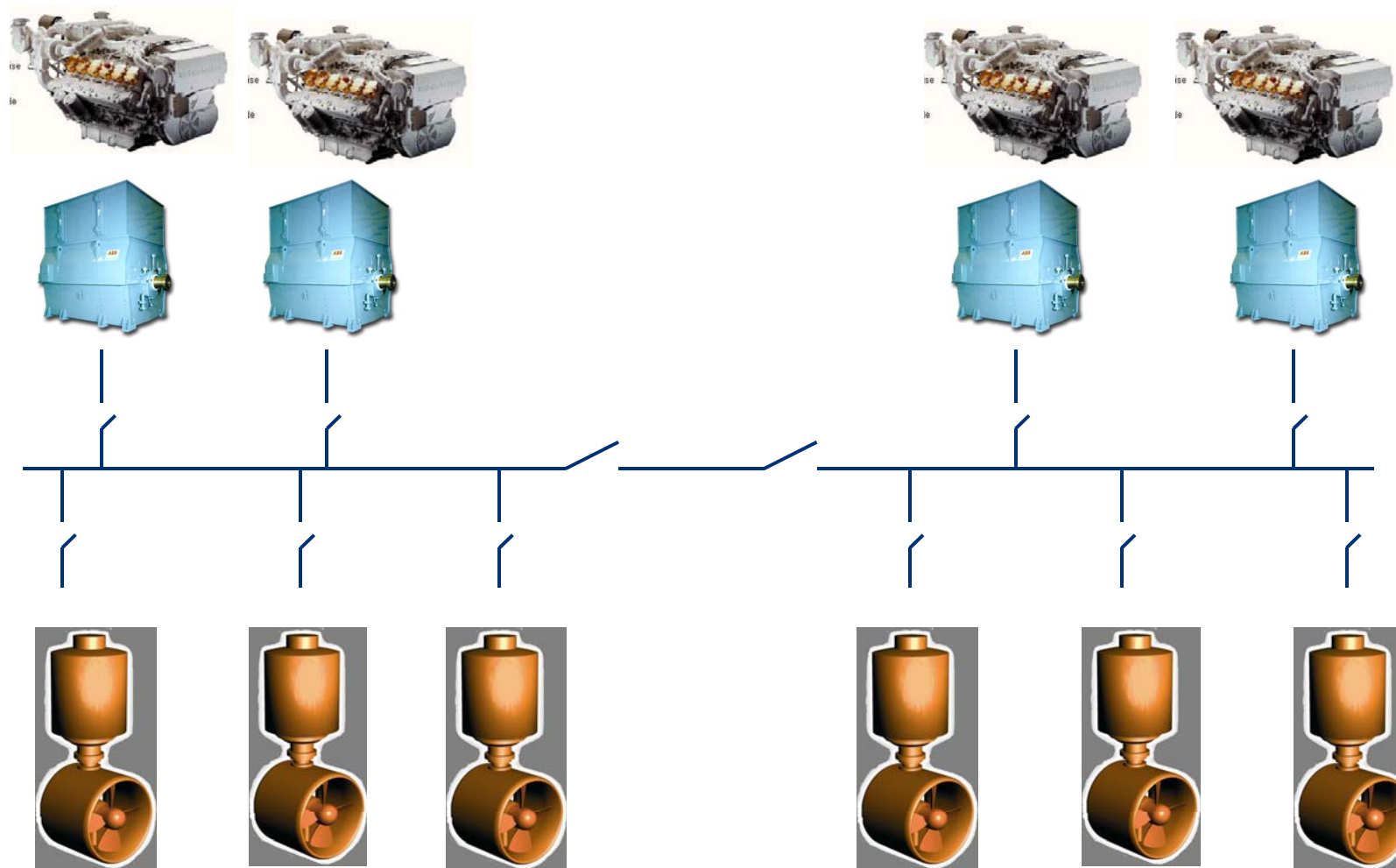

Running power plant with closed bus ties in a diesel electric installation.

- Less generators connected.
- More optimum load on running engines.
 - Environment.
 - Fuel and maintenance cost.

➤ A single failure must not propagate to total blackout!

International Marine Contractors Association (IMCA). DP incident reports.

- In the period 2000 – 2006 appr. **10-24%** of DP loss of position incidents was caused by power generation.

Power plant safety hierarchy



1. Primary protection system in breakers and switchboards.
 2. Power management system and blackout prevention / consumer control system.
 3. Loadsharing monitoring system.
- Level 2 & 3 shall prevent trip of generators, tie-breakers or consumers by primary protection system.

Power Management System (PMS)



- Load sharing. Symmetric and asymmetric.
- Reactive load sharing (power factor control).
- Load dependent start and stop.
- Alarm changeover.
- Blackout reconnection.

- Fast consumer load limitation & reduction.
- Close interaction with DP and thruster control systems.

- Signal verification.
 - Measurement validation, calculation of illegal values.
 - Breaker position and kW validation.
- Redundancy and segregation.

Advanced Generator Supervisor (AGS)

Advanced Generator Supervisor (AGS)

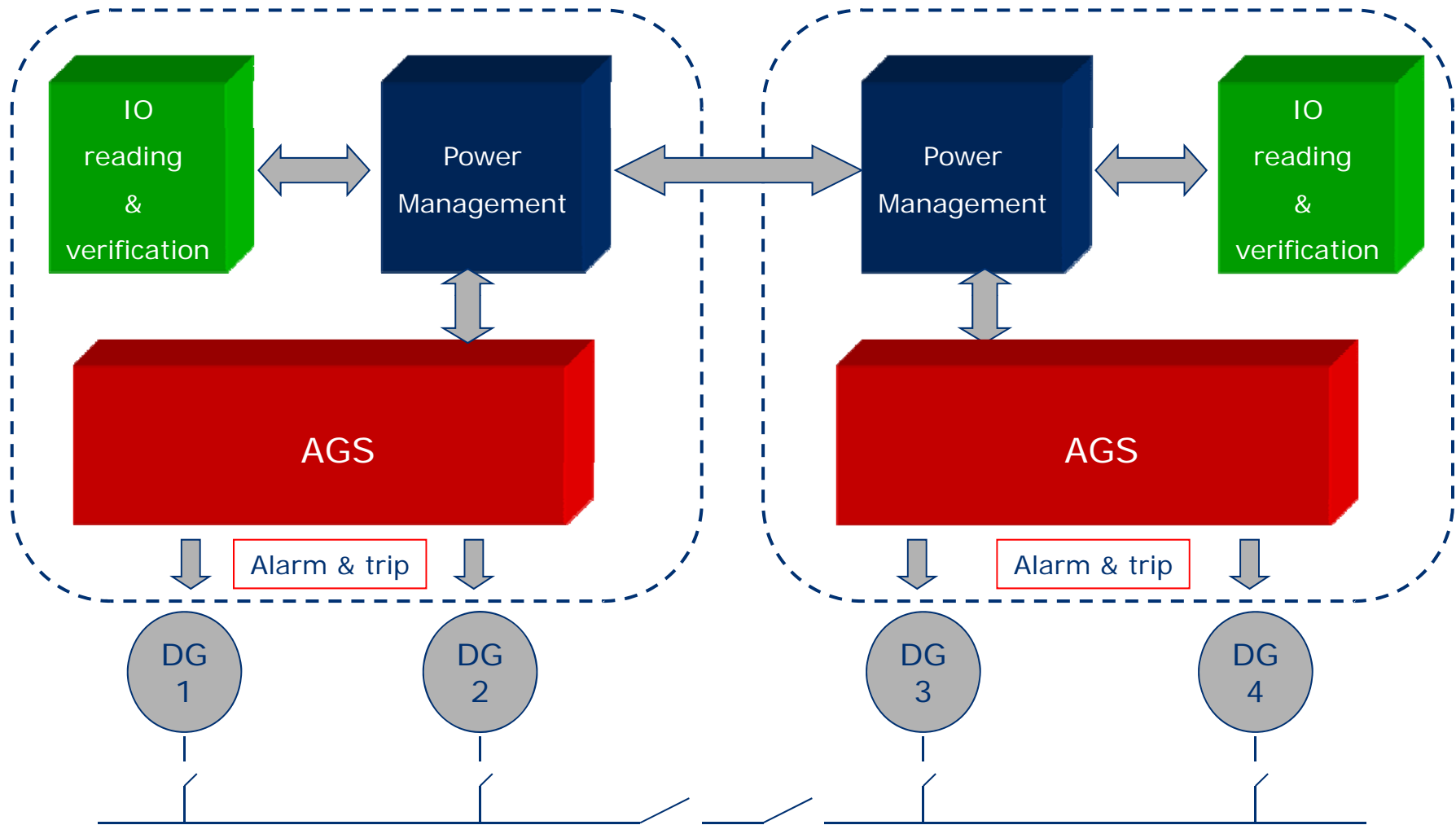

Advanced Generator Supervisor (AGS)



- The goal of AGS is to detect and isolate generators with faulty speed or voltage control system.
 - Avoid full or partial blackouts due to such failures.
 - Be able to operate with closed bus-ties to reduce the number of generators on line => less fuel consumption and emissions.

Advanced Generator Supervisor (AGS)



AGS consists of two main functions:

- Monitoring of speed control system (active load sharing).
- Monitoring of voltage control system (reactive load sharing).

AGS is an expansion of the Power Management System.

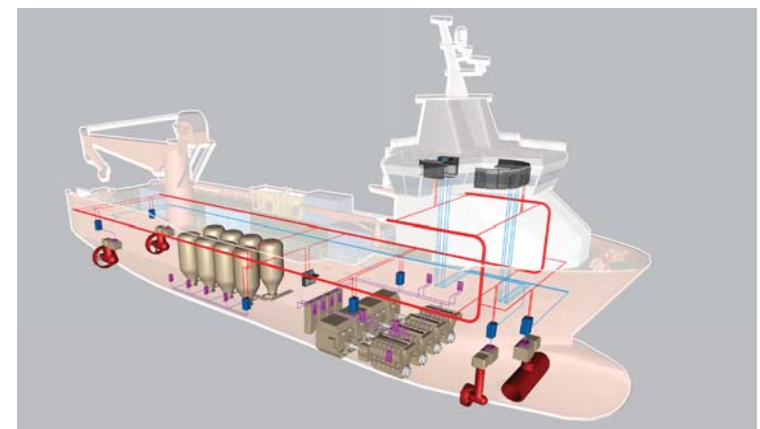

Advanced Generator Supervisor (AGS)



- AGS interact with:
 - Fast heavy consumer load reduction system
 - Dynamic Positioning system (DP).

- AGS is available on:
 - New deliveries
 - Midlife upgrades of older deliveries.

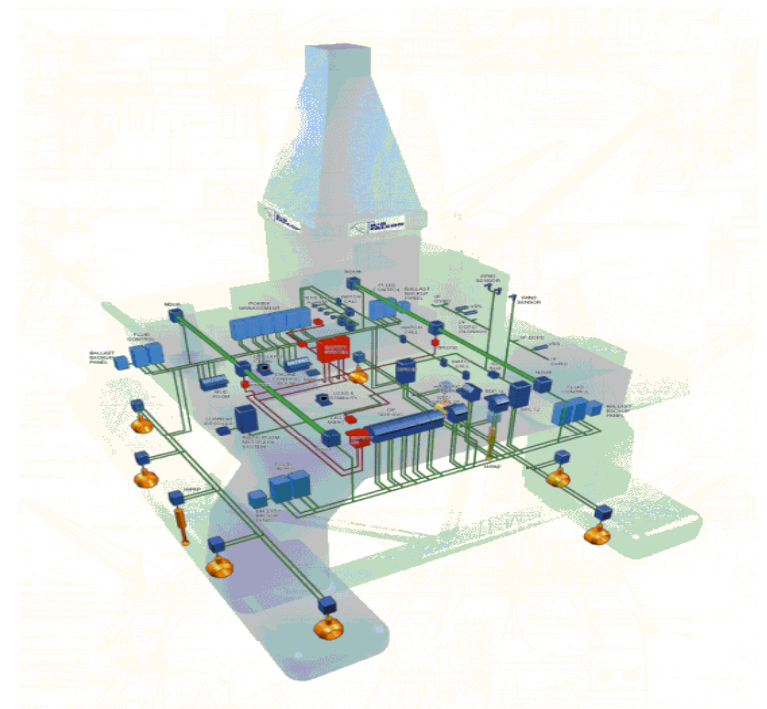

Advanced Generator Supervisor (AGS)

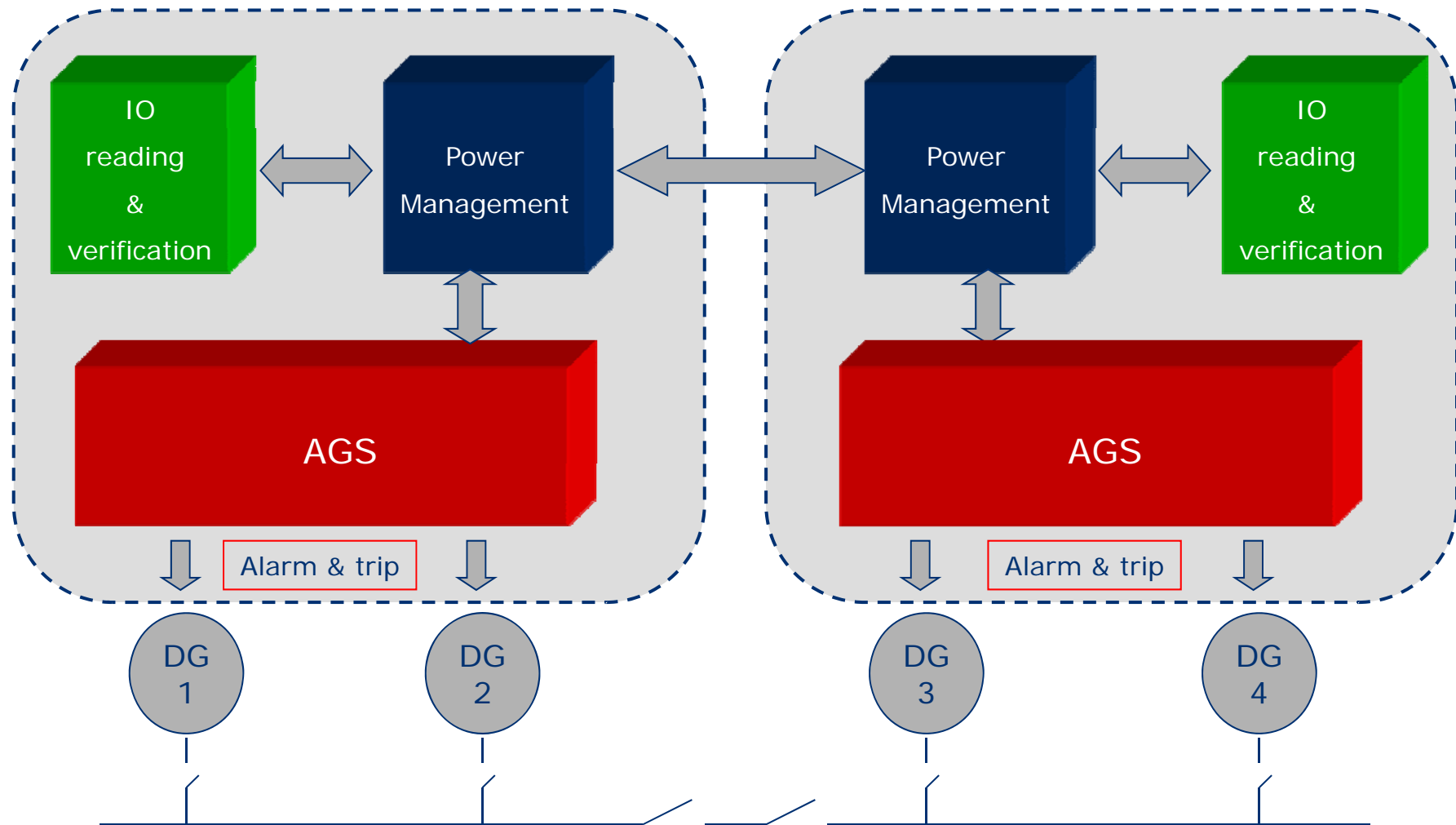

Advanced Generator Supervisor (AGS)

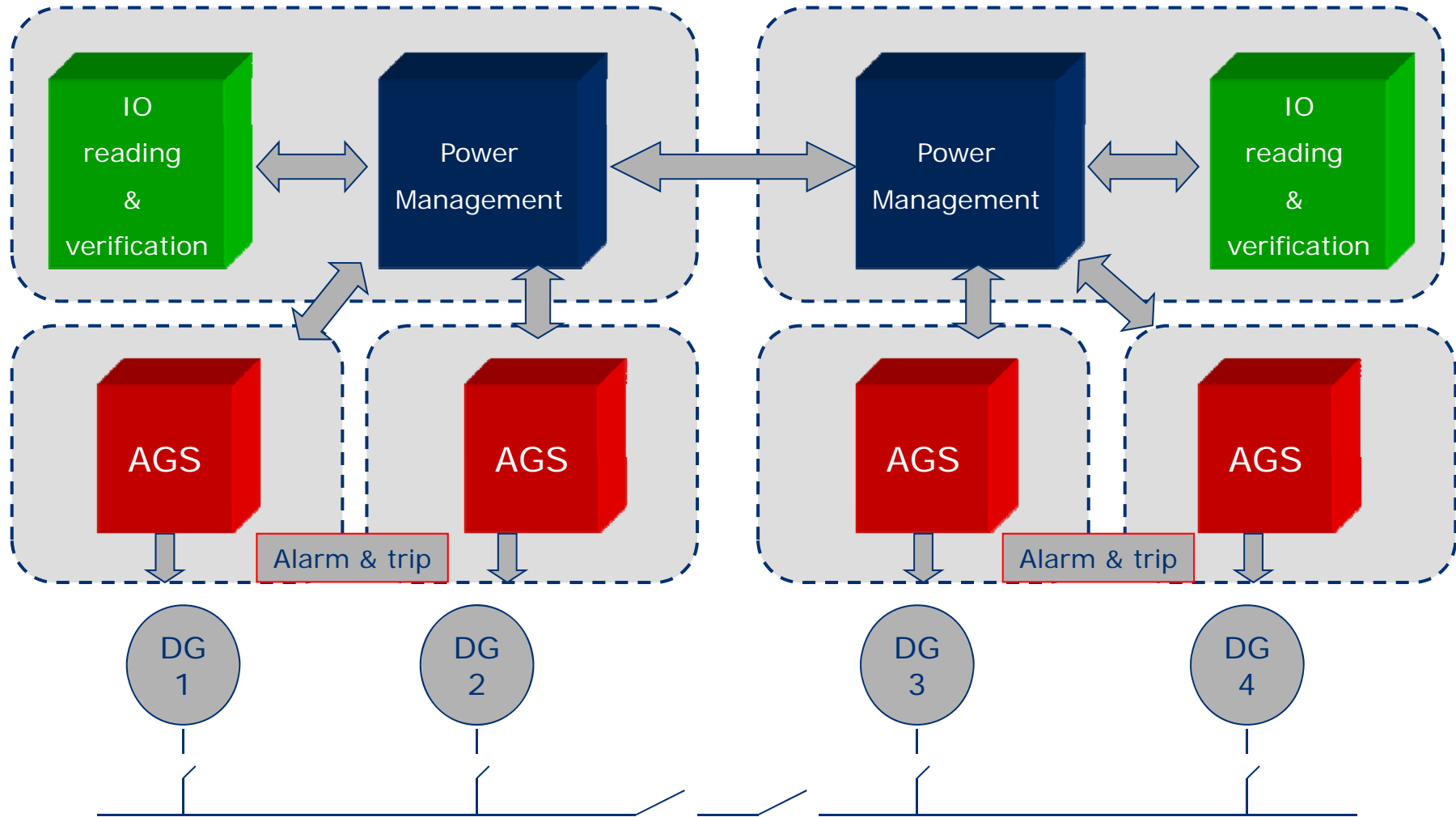

Advanced Generator Supervisor (AGS)



- AGS continuously compares measured values with expected values calculated from a mathematical model of the system to detect which engine has a fault condition.
- First level of deviation:
 - Start standby generator(s) and give an alarm.
- If the deviations exceeds further:
 - Trip the faulty generator.

Available speed control modes

- Compensated droop
- Fixed droop
- Isochronous mode.

Available loadsharing modes

- Symmetric
- Asymmetric
 - Controlled from PMS in compensated droop.
 - Base load / MW control when controlled by an external system in isochronous or fix droop mode.

Typical failures:

- Generator developing too high load. Caused by e.g. governor or actuator failures, feedback failure or PMS control signal failure to the governor.
- Generator not developing required load. Caused by e.g. governor failure, clogged fuel filter or other errors in prime mover.

Failure check based on:

- Net frequency
- Generator kW
- Engine fuel rack position.

Typical failures:

- Over excitation. This can be caused by e.g. loss of voltage feedback to the AVR.
- Under excitation. This can be caused by e.g. AVR malfunction.

Failure check based on:

- Net voltage
- Generator kVAr
- Generator field current.

AGS signal flow

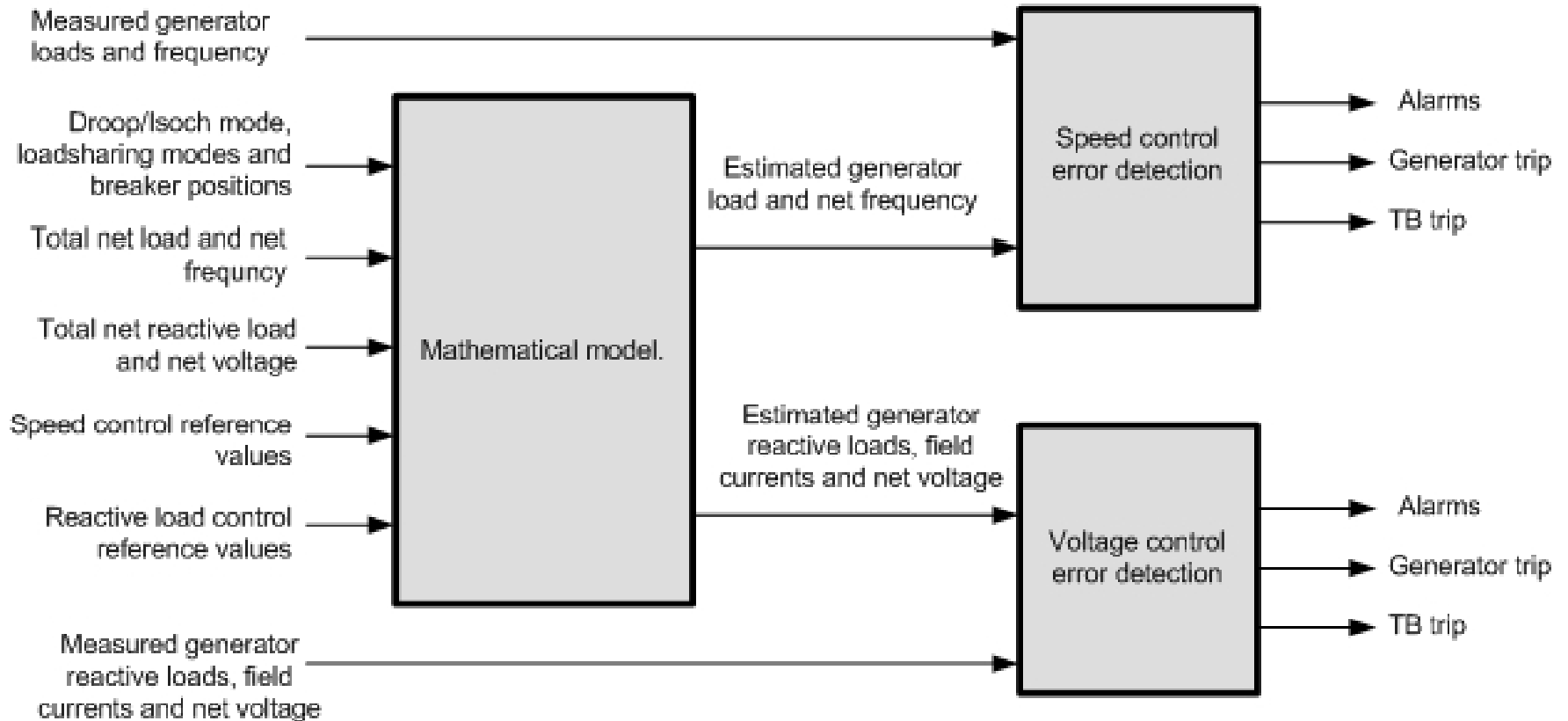

Results from full scale test.

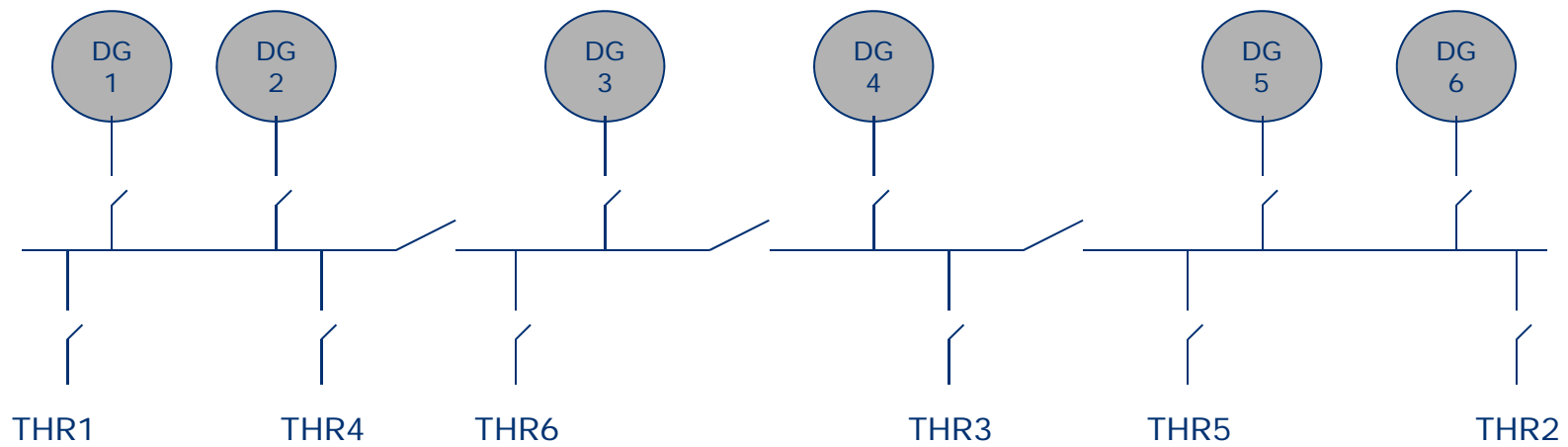

Whithout AGS, Speed control failure.

4 generators online, isochronous mode , appr. 30% load
 One generator forced to increase load.

-> Trip of all 3 healthy generators by breaker protection!

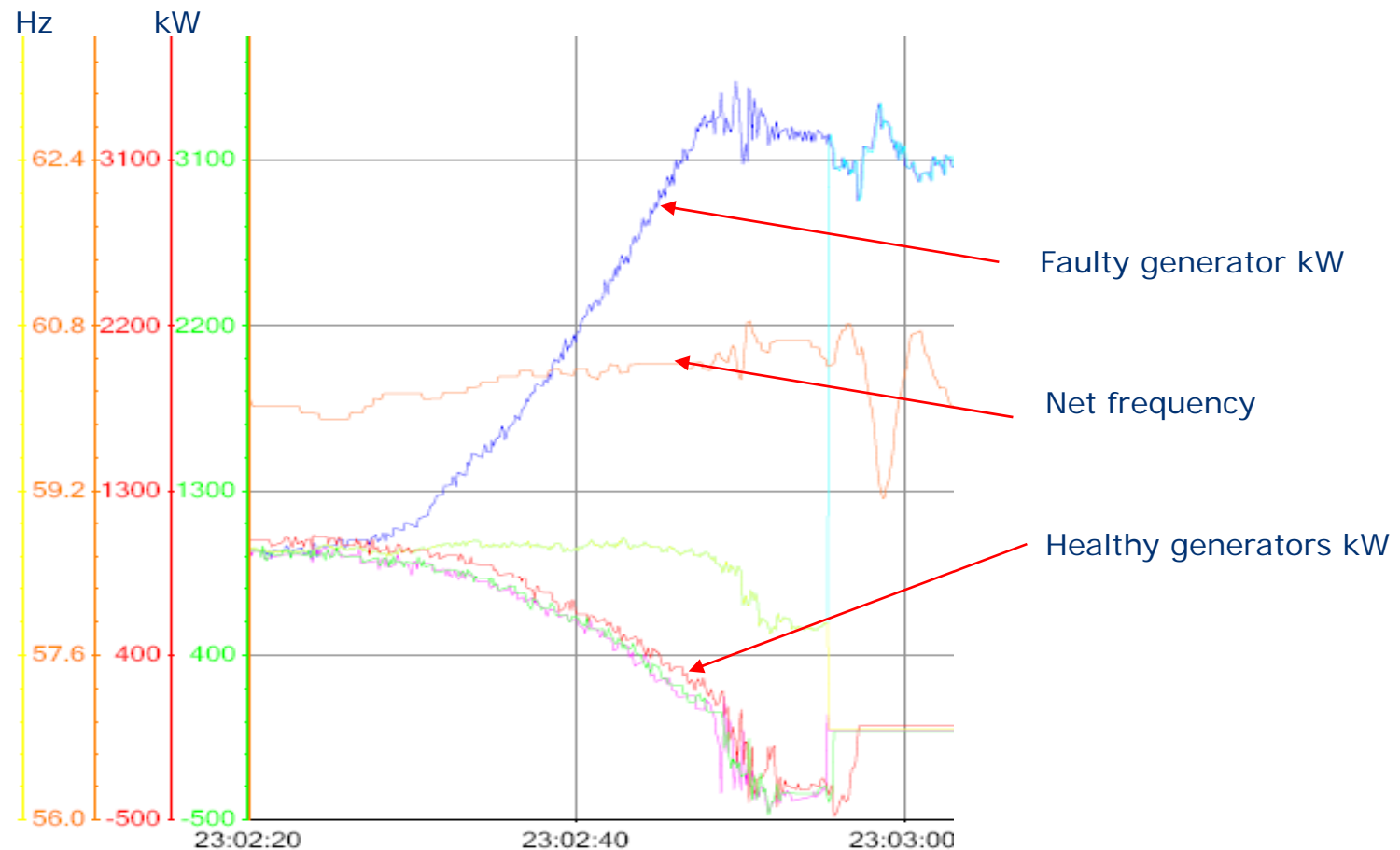

With AGS, Speed control failure.



4 generators online, droop mode , appr. 30% load
One generator forced to increase load.

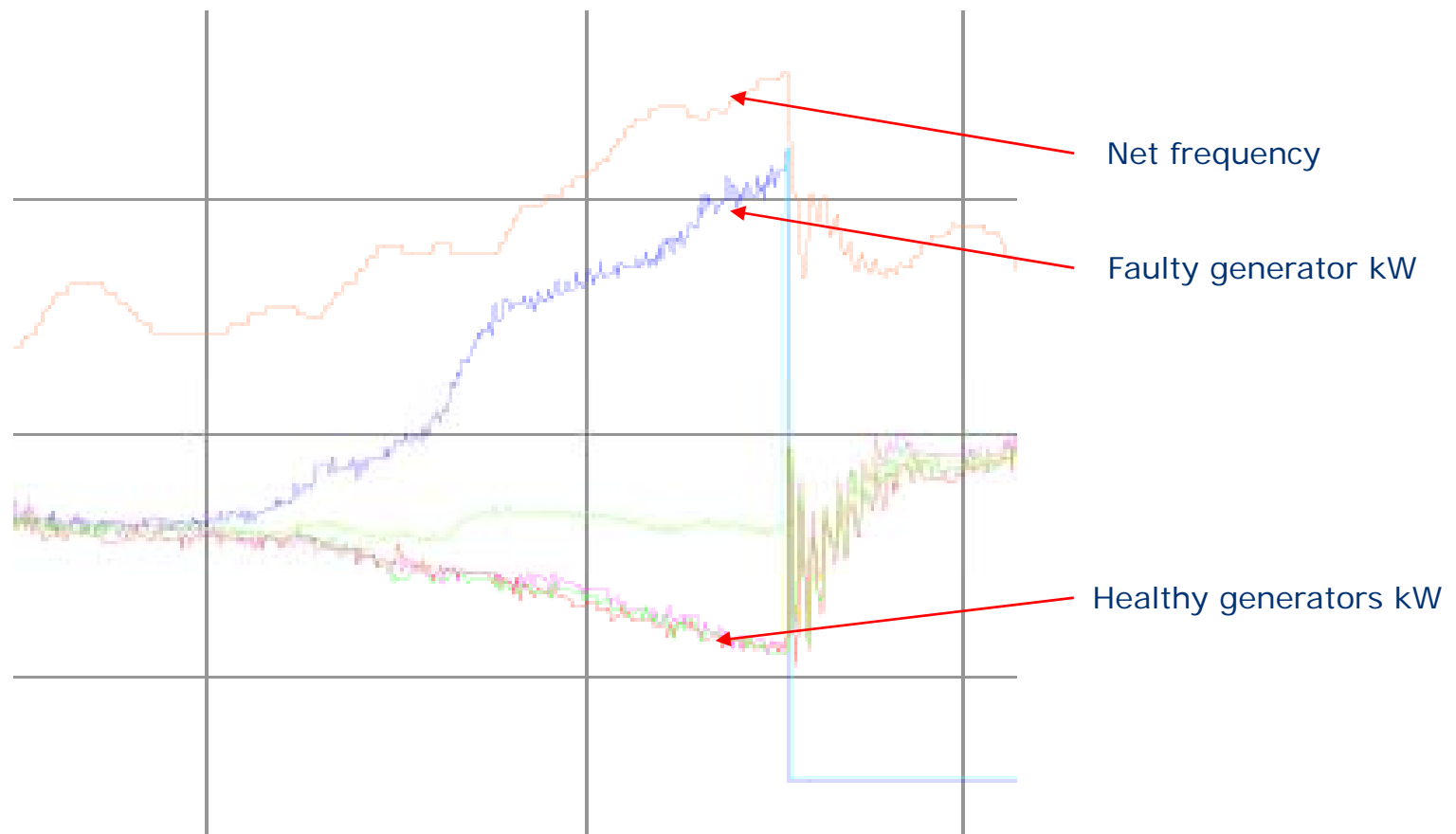

With AGS, Speed control failure.



2 generators online, droop mode, appr. 30% load.
One generator forced to increase load.

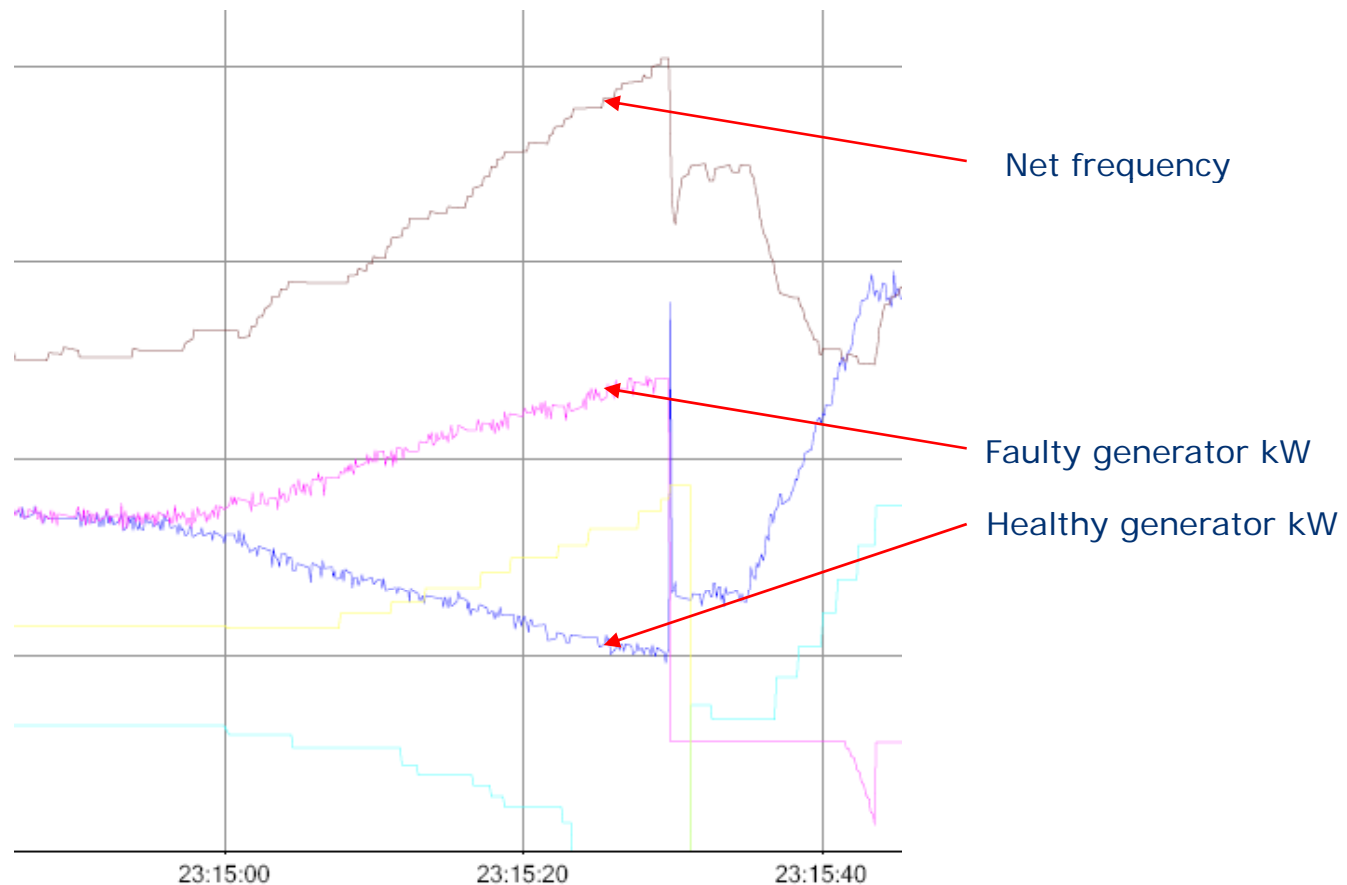



KONGSBERG

With AGS, Speed control failure.

2 generators online, droop mode, appr. 30% load.
One generator forced to decrease load.

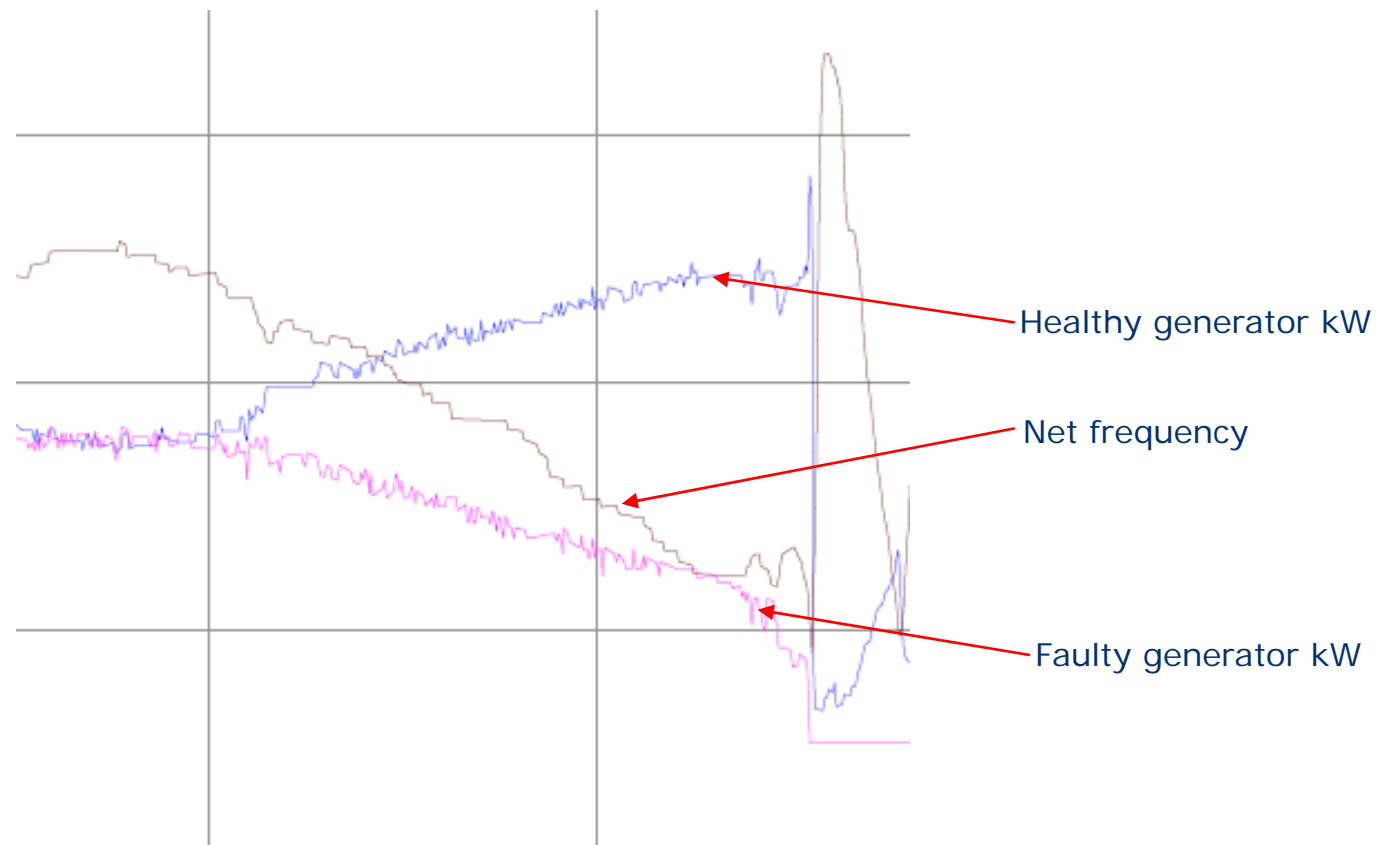

With AGS, Speed control failure, Isochronous

2 generators online, isochronous mode, appr. 30% load.
One generator forced to increase load.

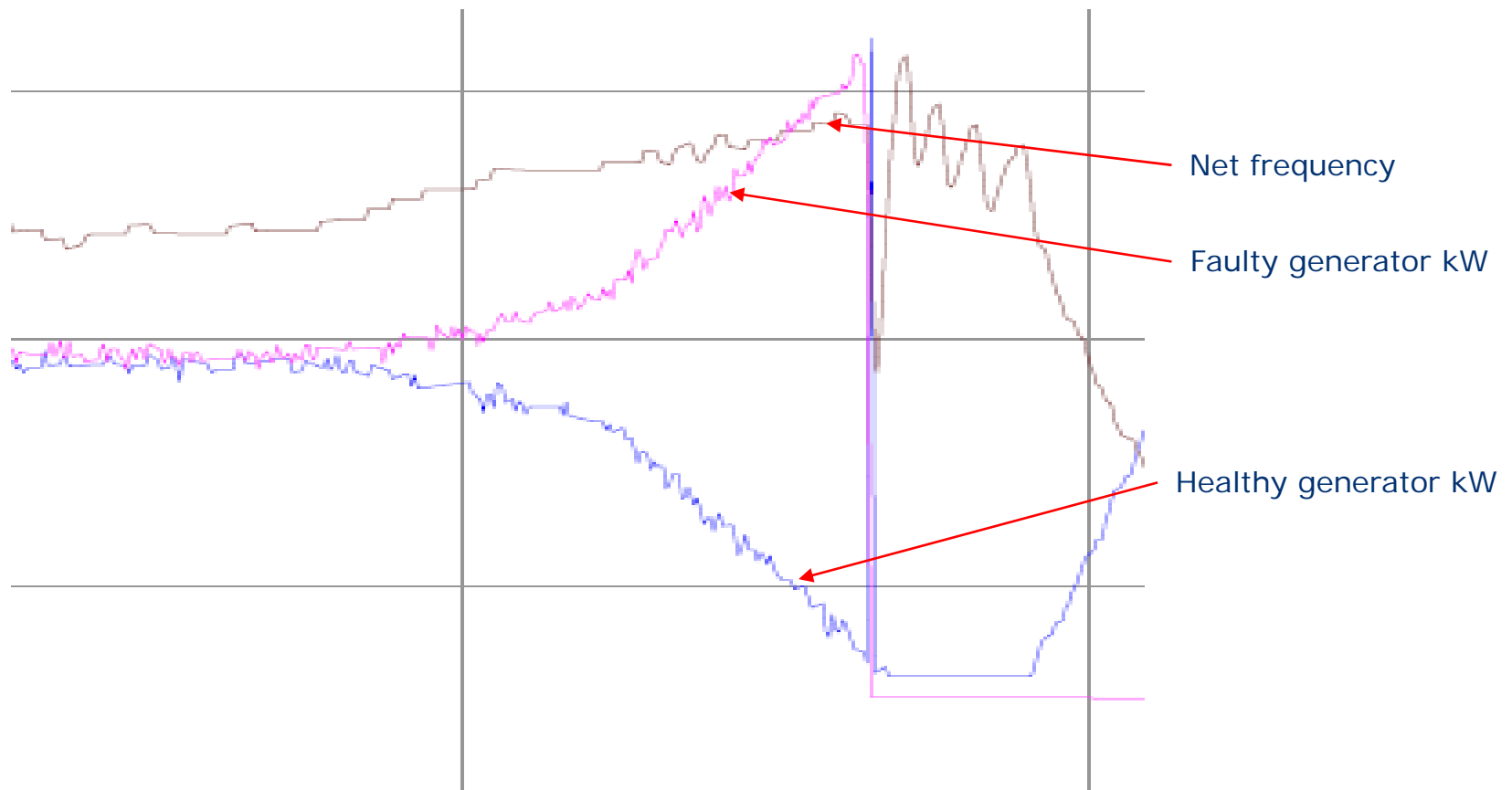

With AGS, Speed control failure, Asymmetric load

2 generators online, droop mode, appr. 30% load.
One generator forced to increase load.

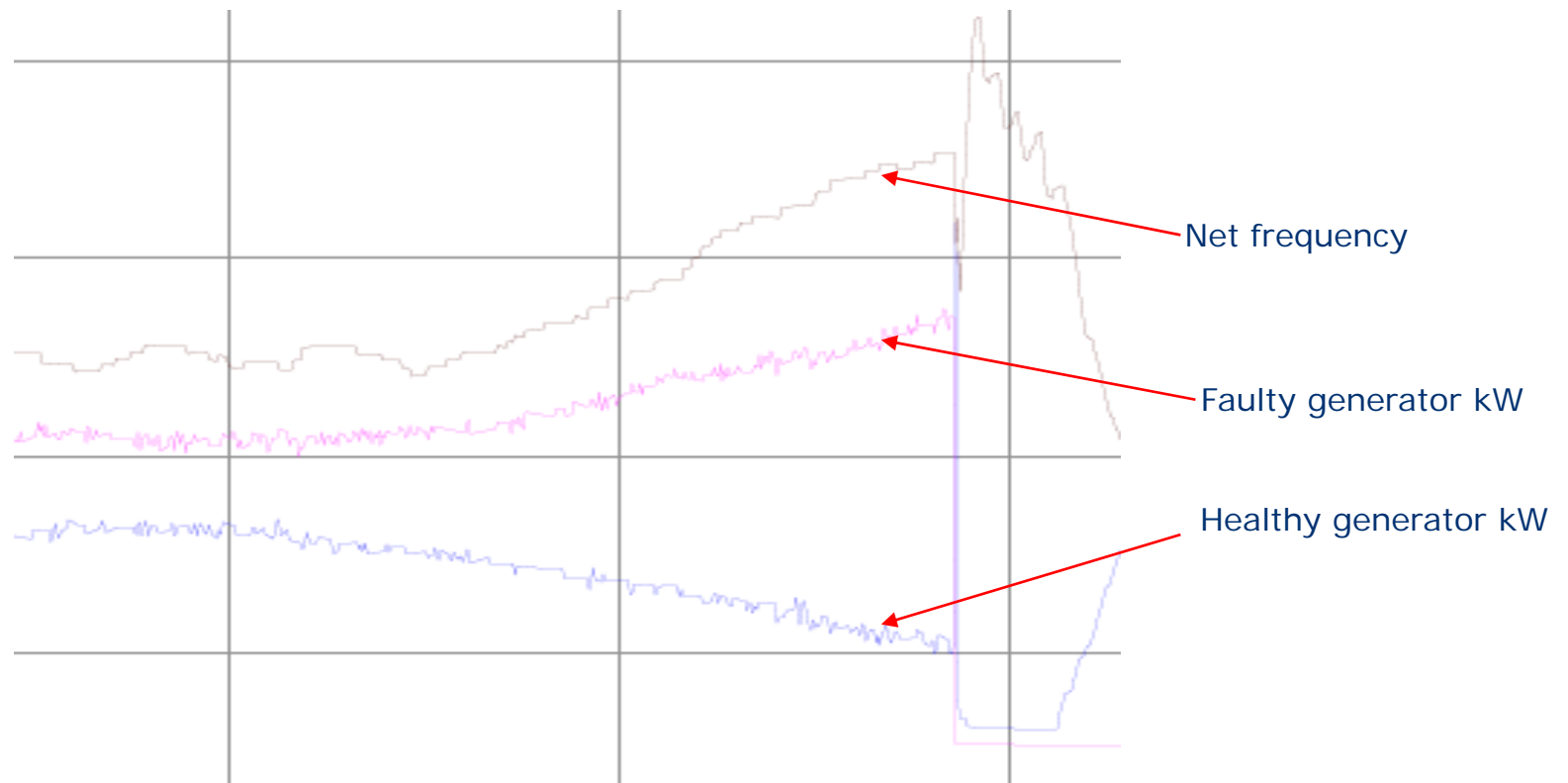

With AGS, AVR failure.

4 generators online, droop mode, appr. 30% load.
One generator with over-excitation.



Conclusion



Full scale tests shows that a model based failure handling system like AGS will work in all the commonly used operation modes.

Thank you for your attention!



KONGSBERG