

OPERATIONS

Reducing Nox Emission in DP2 and DP3 Operations

Bjørnar Realfsen
Kongsberg Maritime

October 13 -14, 2009



KONGSBERG

KONGSBERG

KONGSBERG – Reducing NOx emissions in DP2 and DP3 operations

Bjørnar Realfsen, Kongsberg Maritime, Kongsberg Norway

Introduction



Reducing emission is a highly prioritized objective in most countries.

NOx is one of the pollutants that several governments has put an emission limit on.

Norway has committed to reduce NOx emission with 30% within 2010.

The marine industry shall be a significant contributor to reach this objective.

The most common method for exhaust purification is Selective Catalytic Reduction (SCR).

Supply vessel design and operation

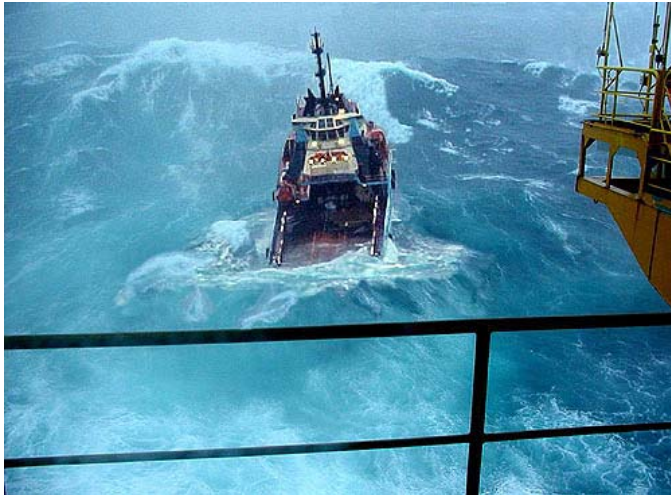

Supply vessels are typically designed to withstand extreme weather forces.

Class requirements states that the vessel must have full redundancy for thrust and power at all times.

DP operations are normally done in calm or moderate weather.

Modest thrust demand for DP usage.



Power producers and -consumers

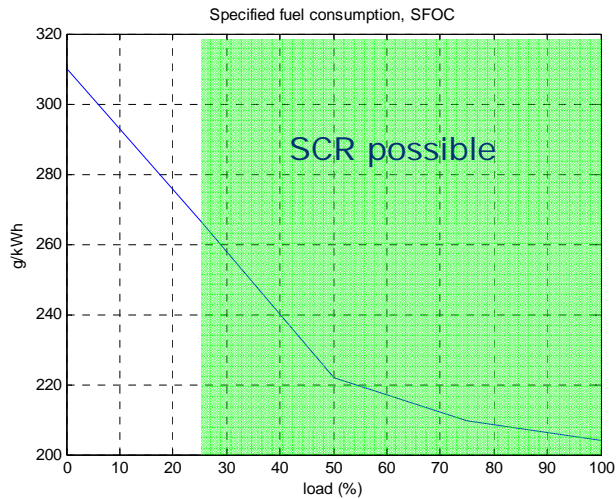

A typical generator has best efficiency at high load.

Generator load must exceed 25-30% in order to engage SCR.

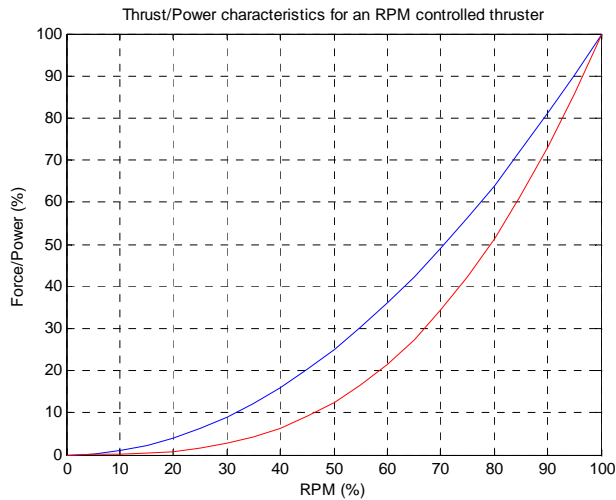

A typical thruster has best efficiency at lower load.

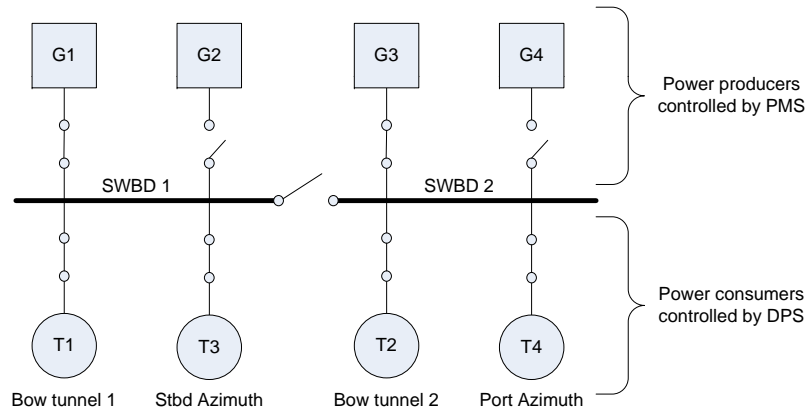

NOx emission vs. fuel consumption

NOx emission: 12T thrust in bow and 7T thrust aft. Hotel load is 100kW on each swbd

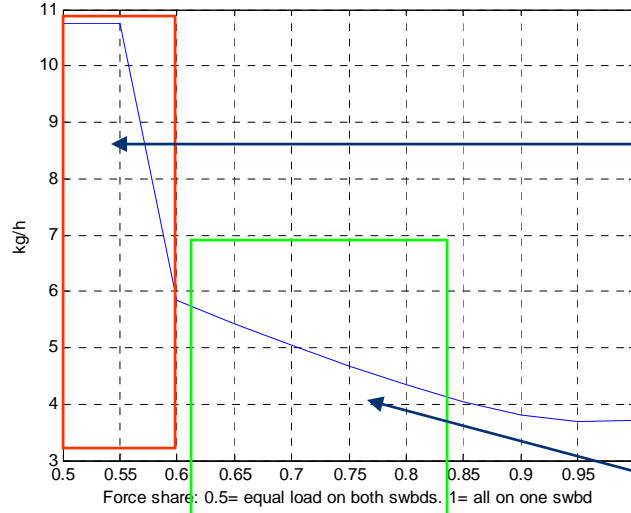

High NOx emission area

Best working conditions

Fuel consumption: 12T thrust in bow and 7T thrust aft. Hotel load is 100kW on each swbd

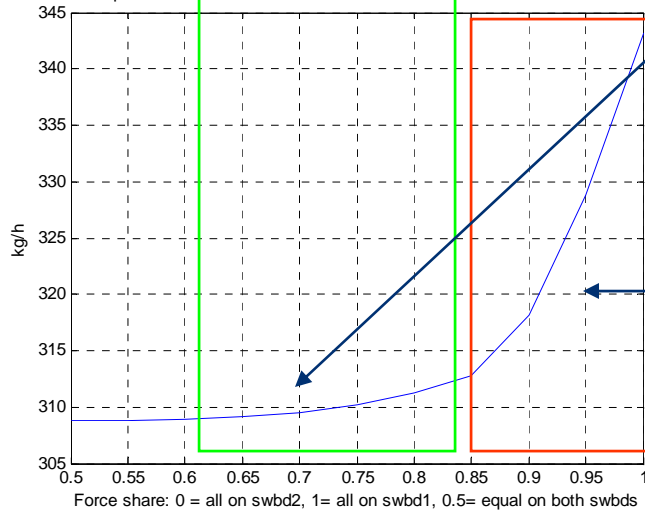

High fuel consumption area

Load share strategies

- **Thruster Force Bias**

The advantage with respect to NOx cleaning is that this strategy can increase load on all generators.

The major disadvantage is that it results in significantly increased fuel consumption.

- **Hibernating thrusters**

“Disable” thrusters on one swbd.

This will lead to significant increase in fuel consumption.

- **Power optimal thrust allocation**

The thrust allocation ensures that the generators and thrusters are working with “optimal” conditions. The allocation mode is called *Increased swbd load*.



Power Optimal Thrust Allocation



The main objective is to minimize the squared thrust used:

$$g_0(t) = \frac{1}{2} \cdot \left(\sum_j w_j \cdot (t_j)^2 \right)$$

The weights w_j are normally set to the inverse of the maximum thrust.

In *increased swbd load mode* we calculate weights so that we achieve the desired load on the selected swbd.

No bias thrust is added to achieve the desired load if the thrust demand is too low.

A new calculation is done for each sample, based on the current power feedback from generators and thrusters.

Power optimal thrust allocation

Setup1

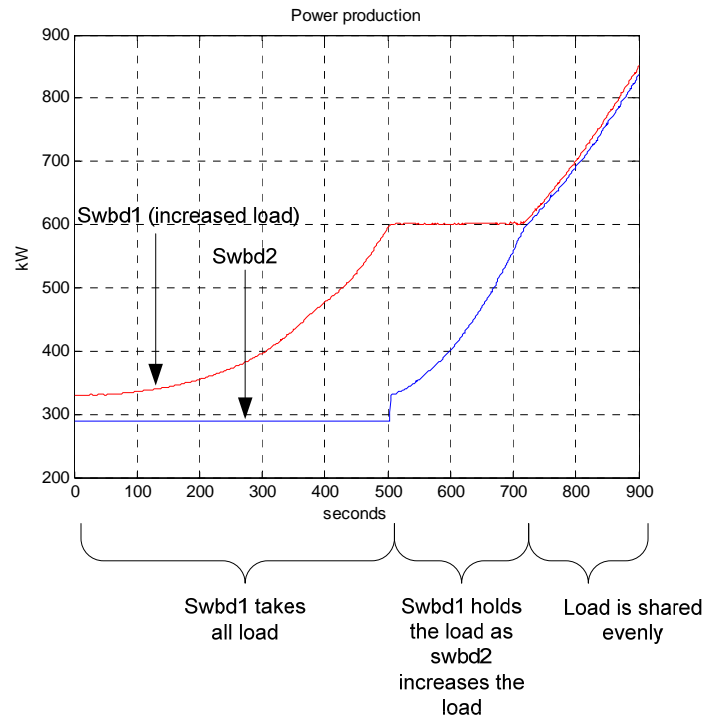

Setup2

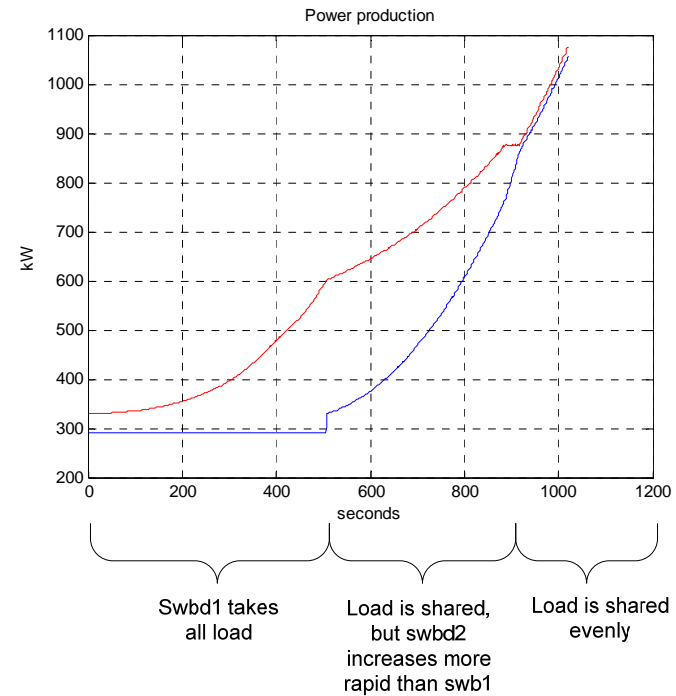

Different load share strategies can be achieved by changing the calculation of the weights in the objective.

Simulations

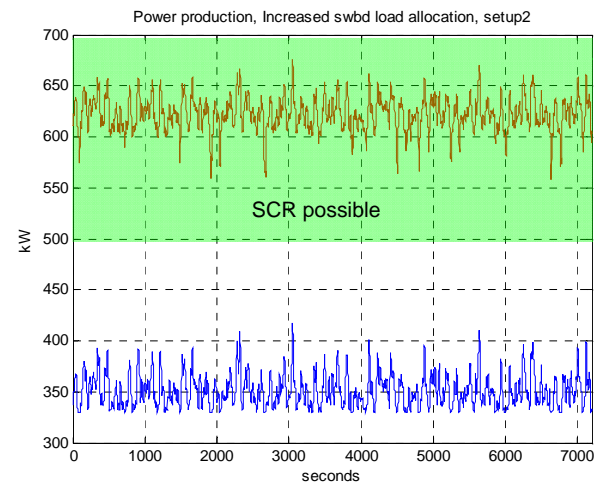
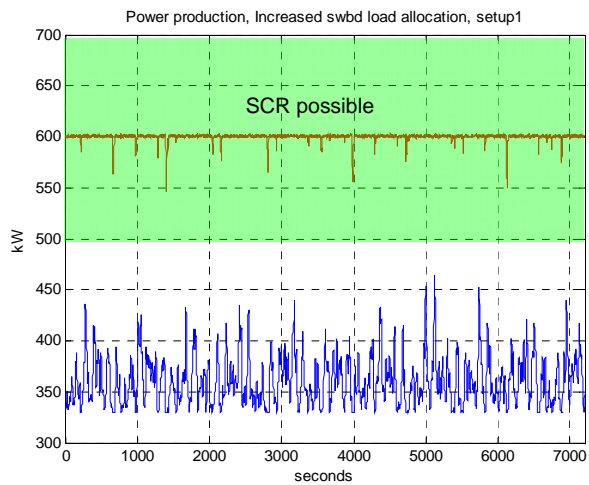
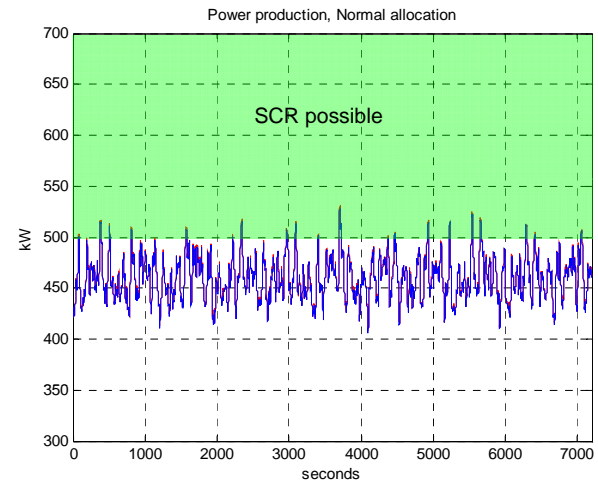
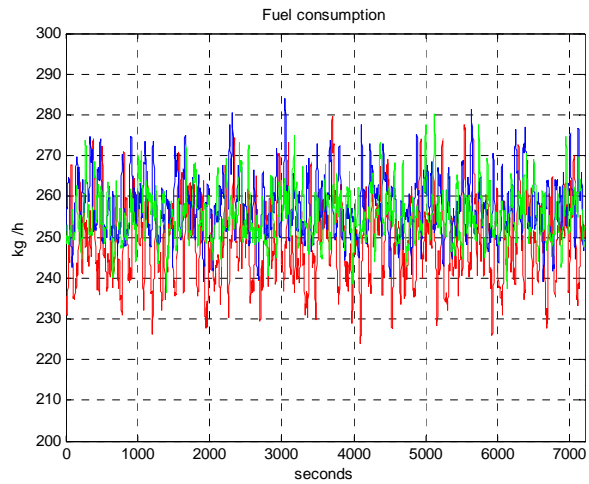

Simulations



Emission of NOx is reduced with 44% when Increased swbd load mode is active.

The fuel consumption increased with 2.5-3.5%.

No significant differences with respect to fuel consumption between different setups for the weight calculation in the thrust allocation.

Edda Frende



“Edda Frende” (Østensjø Rederi As, Norway) was the first vessel to have *Increased swbd load* functionality installed.

The feedback from the vessel is that the functionality works as desired.

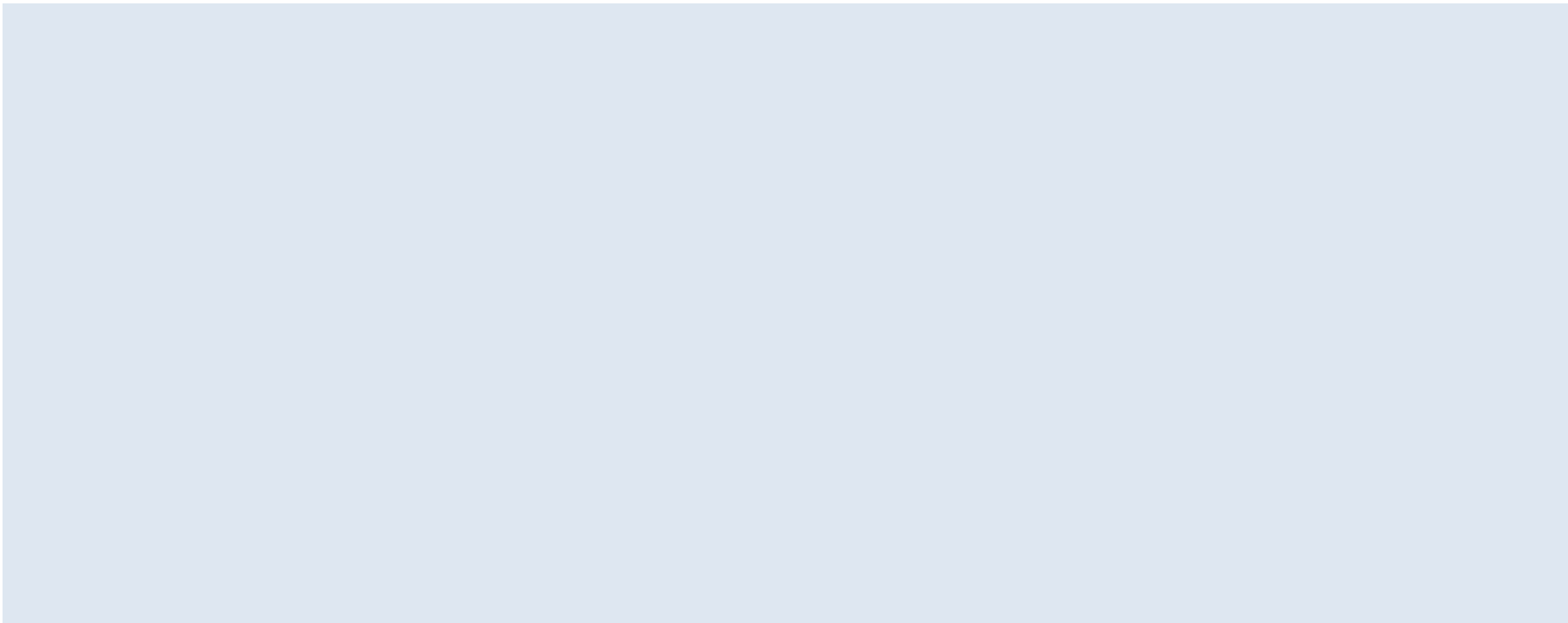

KONGSBERG