



DYNAMIC POSITIONING CONFERENCE

October 13-14, 2009

Operations

Stationkeeping in Solid Drift Ice

Dietmar Deter

Nautex Inc., Houston, USA

Willy Doelling

Wärtsilä Ship Design Germany, Hamburg, Germany

Lester Lembke-Jene and Alfred Wegener

Institute for Polar and Marine Research, Bremerhaven, Germany

ABSTRACT

The paper discusses certain aspects in the development of the AURORA BOREALIS (AB), a dynamically-positioned Polar Research and (Scientific) Drill Vessel for the European Polar Research Icebreaker Consortium (ERICON).

The design of the vessel was contracted with Waertsilae Ship Design Germany (WSDG) under the project management of Alfred Wegener Institute for Polar and Marine Research (AWI).

The AB is a heavy icebreaker with the highest ice class. She is powered to break continuously in more than 2.5 m of multi-year ice and is able to manage ridges up to 15 m. The ship shall perform research tasks including scientific drilling year-round in the Arctic and Antarctic without any support vessels.

The key issue in the performance specification of the vessel is the mandatory requirement of performing stationkeeping operations in drifting solid ice of more than 2.0 m thickness during drilling and other research tasks.

The paper presents and discusses the design challenges and problems, as well as the test results and design solutions. It includes selected results of the ice tests for stationkeeping in drifting solid ice of up to 2.0-meter thickness, i.e., icebreaking in a practically stationary mode, which was carried out in two ice tanks in Helsinki and Hamburg.

For the various propulsion tasks -- transit at 16 knots, icebreaking, and stationkeeping in ice -- a propulsion system is installed totaling 108,000 kW.

Conclusions: A great amount of propulsive power is required to implement the tasks of stationkeeping and icebreaking applying conventional ice breaking techniques, i.e., providing icebreaking forces through propulsors. As an alternative, the breaking of ice in stationary mode of the vessel by means of induced motions on the vessel was investigated.

New approaches regarding the dynamic positioning control techniques may be required for full automatic DP operations in ice.

Based on the results of the AB design effort, we conclude that stationkeeping operation in solid drift ice is feasible.

Currently, several leading oil companies are conducting research regarding exploration in Arctic waters. The presented results are of significant importance for all projects dealing with stationkeeping of offshore vessels in ice. The results are a valuable addition to the database of knowledge regarding Arctic vessels in general and, in particular, stationkeeping in ice.

STATIONKEEPING OPERATION IN SOLID DRIFT ICE

The Design, Ice Tests, Challenges, and Solutions for the Polar Research Vessel AURORA BOREALIS



The AURORA BOREALIS is a multipurpose research vessel for worldwide operation. The vessel was designed to meet current and future requirements of the ocean research community, and shall be prepared to comply, as far as feasible, with future rules, regulations and limitations imposed by environmental protection agencies in the decades ahead.

The AURORA BOREALIS is unique. Never in the history of naval architecture was a vessel designed for the mission scope of the AURORA BOREALIS, ranging from heavy icebreaking to scientific deep-ocean drilling while the vessel is captured in solid, drifting sheet ice. During drilling missions (and other operations) in open water, the vessel is automatically positioned. The forces acting on the vessel due to ice drift, winds, current, and waves are counteracted with the vessel's high-powered propulsion system.

During stationkeeping in solid, drifting sheet ice it is anticipated that the position of the vessel will be initially controlled manually (in joystick mode of the DP control system) until new technologies are available from the DP control system manufacturers. Due to the very slow changes in drift ice angle and velocity, a manual control is feasible and safe.

DESIGN

The development and design of the vessel was contracted with Waertsilae Ship Design Germany (WSDG) (former SCHIFFKO) in Hamburg. WSDG was responsible for the total design scope of the vessel, including the hull design optimization for icebreaking and transit operations, and the stationkeeping concepts. As the designers of the outstandingly successful Polar Research Vessel POLARSTERN, WSDG was the logical candidate for the design of the AB. The design program was managed by the scientists and engineers also of the current operators of the POARSTERN, and the future operators of the AB: the Alfred Wegner Institute for Polar and Marine Research (AWI).

The WSDG's design effort of the vessel took over 18 months. An extensive program of ice model tests in two leading institutes confirmed the validity and quality of the WSDG design concept. An unparalleled period of 27 days of model testing explored any possible aspect of the interaction of a vessel with the surrounding ice - while icebreaking or attempting to keep station in drifting ice.

SCOPE

The design of the vessel included a myriad of tasks and design challenges. This paper focuses on the specific task of stationkeeping in solid, drifting ice sheets in up to 2.0 m thickness. It discusses the design features, the performance, and its limits under these operating conditions.

VESSEL DATA

Length over all	199.95 m
Length between perpendiculars	174.27 m
Breadth, max.	49.00 m
Breadth, waterline	45.00 m
Depth main deck	17.75 m
Depth forecastle deck	24.75 m
Draught, design	13.00 m
Draught, max.	13.25 m
Service speed	15.5 knots
Maximum speed	20.0 knots
Class notation	IACS PC1
Installed power	94 MW
Main propulsion power	81 MW
Transverse thruster power	6x4.5 MW

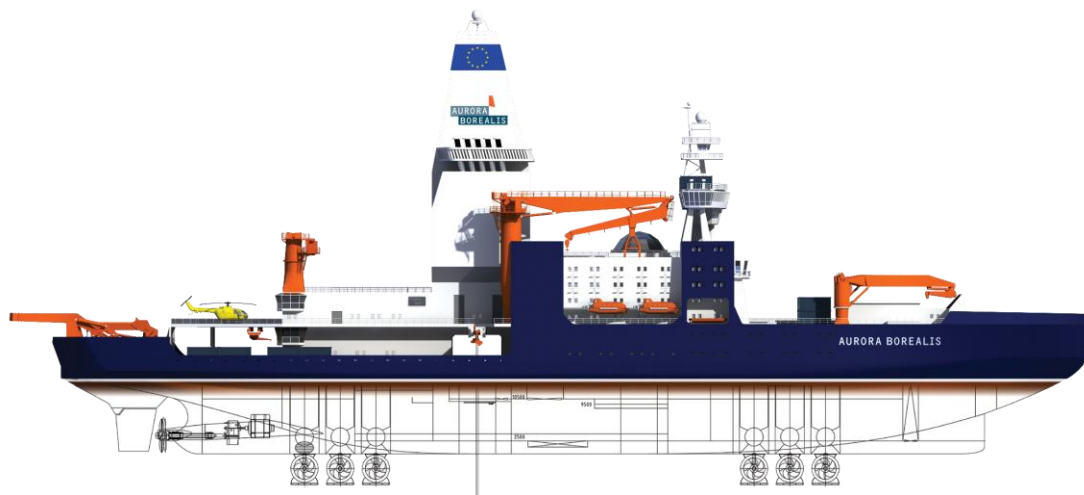

TASKS, ENVIRONMENT, OPERATING CONDITIONS

The operational envelope of this ship is larger than any other vessel. It operates in heavy ice and in open waters (including tropical). The governing design aspects, e.g., for the propulsion system, are icebreaking and stationkeeping in heavy ice rather than medium speed sailing in open water.

The vessel shall be able to operate in Arctic and Antarctic regions as well as in all other oceans in the world including areas sensitive to environmental regulations which already have restrictions regarding noise and other types of pollution or which may become restricted in the near future.

Missions to be performed by the ship include:

- Scientific drilling for core samples in solid ice, between 100 and 5000 m water depth, and a drilling depth of 1000 m and more.
- Scientific drilling in open water in Sea State 6 conditions and Beaufort 8 scale wind while dynamically positioned.
- A wide range of oceanographic missions, some of these while the vessel is dynamically positioned.
- Transit operations over extended periods of time, i.e., cruising from Arctic to Antarctic regions.
- Year-round operation in the Arctic and Antarctic, i.e., capability to stay in the region during a full winter period.

Significant Operating States

The following (minimum) operating states became the basis for the development of the DP system and the stationkeeping analysis:

- Stationkeeping in Ice: The vessel shall be able to keep position (i.e. maintain heading and position with reference to the center of drilling) in drifting sheet ice of 1.0 to 2.0+ m thickness.
- DP in Open Water: The vessel shall be able to keep position in the following states:

Sea State 6

Significant wave height	5.0 m
Wave period	12.4 sec
Current velocity	1.5 knots (0.771 m/sec)

Beaufort Scale 8

Wind velocity	38 knots (19.53 m/sec)
---------------	------------------------

This paper is focusing on Stationkeeping in Ice.

PROPULSION SYSTEM

Introduction

During stationkeeping missions, the vessel is attacked by environmental forces such as ice drift, wind, waves and current. In order to maintain a certain position, these forces have to be counteracted by the vessel's propulsors.

The dynamically positioned vessel has to be able to provide the forces required to execute maneuvers in surge, sway and yaw. These forces must be controllable in magnitude from zero to full power, and in direction through 360 degrees.

A variety of options are available in order to achieve this goal. The ocean industry developed many successful designs for DP drill vessels and other offshore and construction vessels. None of these designs would qualify as an example for the propulsion needs of the AB.

The task of developing a propulsion system for a vessel with the variety of different mission as required for the AB is unique and unprecedented.

The propulsion system of the AB, had to be developed to comply with the following mission requirements:

- Transit over extensive distances (e.g., from Arctic to Antarctic) at a relatively (for DP vessels) high speed (15.5+ knots service speed, 20 knots maximum speed)
- Icebreaking for extended time periods
- Stationkeeping in ice
- Stationkeeping in open water

Design Basis

The following *design basis criteria* were developed by the designers at the start of the project. They include:

- *Uncompromising design for maximum robustness, reliability and redundancy of all systems and components*
- *Utmost simplicity of all components in order to reduce the rate of failures and maintenance requirements*
- *As far as feasible, access to all components and systems while the vessel is afloat and in operation in order to allow field maintenance and repairs without the need of support vessels or dry docking the vessel*

In response to the above listed mission requirements and design basis criteria the following guidelines for the propulsion concept were established:

- 1 In order to break ice under specified conditions, the vessel must be equipped with a high-powered conventional main propulsion system. No reliable alternative is available at this time.

This large amount of propulsive force installed in longitudinal direction can and shall be utilized during stationkeeping.

Utilizing these available forces in conjunction with simpler propulsors generating thrust only in transverse direction eliminates the need for more complex propulsors which are capable of delivering thrust, which is controllable in direction. Solution:

- 2 Installation of several fixed-direction, reversible, (bi-directional) transverse thrusters in the forward and aft sections of the vessel. These thrusters are only used during stationkeeping in open water and in ice. They have to be retracted inside the hull for the reduction of the draft as well as the resistance of the vessel during transit. They are also retracted during icebreaking operations.

This arrangement presents the ultimate solution in response to the above-stated design basis criteria. It eliminates thrusters with directional control (no azimuthing systems), as well as other propulsors installed in vulnerable positions below the hull and exposed to floating ice.

Disadvantages of the proposed system include:

- Lower system efficiency during certain DP conditions (vector force resultants must be compensated by forces in X and Y direction).
- The lack of directional control of the thrusters reduces their capabilities for ice management tasks.

Final Selection of the Propulsion System Components

Main propellers:

The main propulsion system consists of an arrangement of three propellers with the following characteristics:

Diameter	6.5 m
Power	27000 kW
RPM	100 (varies with the operation)
Thrust	Maximum bollard pull thrust (effective force at zero inflow velocity): 2230 kN

Note: This thrust capability is far in excess of any required amount of thrust for stationkeeping in longitudinal direction of the vessel. For this reason, the main propellers were not even considered in the stationkeeping capability calculations.

The main propellers are five-bladed fixed-pitch propellers of nickel-aluminum bronze with detachable blades. The type of mounting will allow exchange of a blade (by divers) while the vessel is in operating draft.

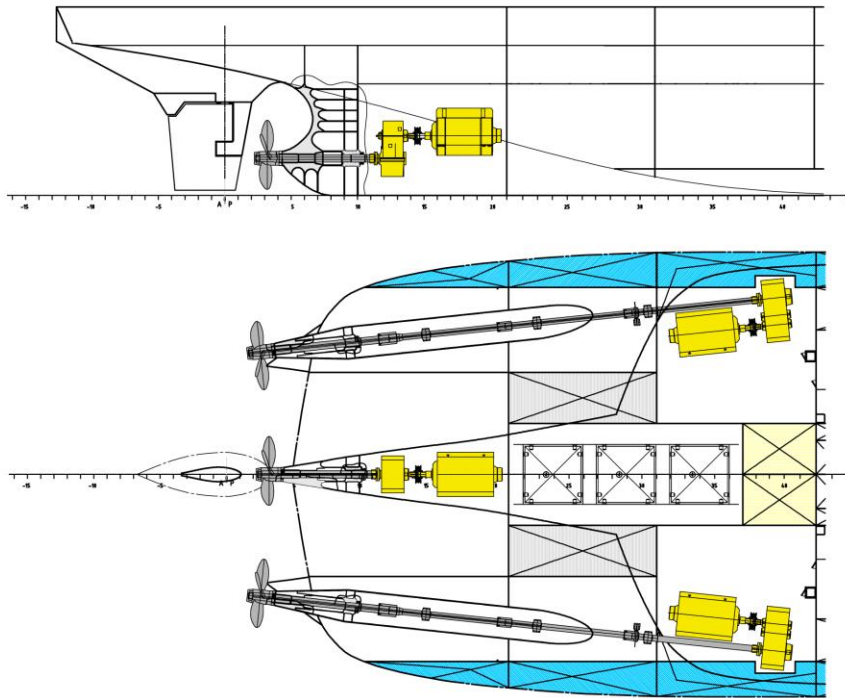

Main Propulsion Arrangement

WSDG designed aft body and main propellers (HSVA Model)

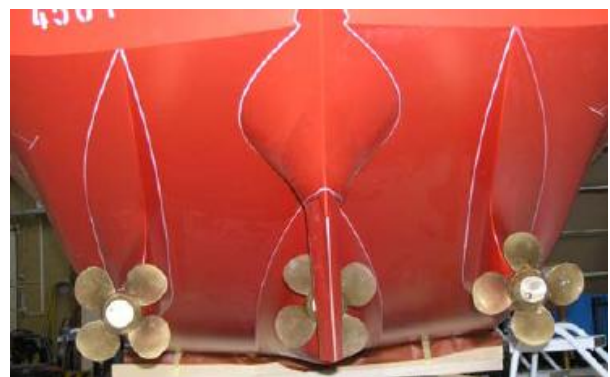

Transverse Thrusters:

Six fixed-direction, transverse thrusters will be installed; three in the forward and three in the aft section of the vessel.

The assessment of the amount of thrust required for stationkeeping in ice and open water depends on data achieved through the model tests. However, the vessel design effort needed information regarding the geometry and weight of the proposed thrusters long before the test results became available. We carried out basic estimates and used those to determine a thruster concept. We started with a highly efficient thruster configuration and calculated the basic design parameters such as propeller diameter, etc. The configuration was made with an increase in power (and thrust) in mind, should it be required.

The pertinent thruster data are:

Propeller diameter	4.1 m
Power range investigated:	3500 kW, 4500 kW, 5500 kW, and 6400 kW (maximum configuration)

Transverse Thruster Arrangement





WSDG designed stern with aft transverse thruster group and main propellers
(Aker Arctic Model)

STATIONKEEPING OPERATIONS IN ICE

Introduction

For the development of the stationkeeping in ice concept of the AURORA BOREALIS, two distinct different modes of icebreaking were investigated:

- **Propulsion Mode:** Conventional icebreaking utilizing the installed propulsors (main propellers and transverse thrusters)
- **Vessel Motion Control Mode:** Icebreaking of the vessel in stationary condition by induced roll and pitch motions of the vessel

Due to the enormous forces caused by solid drifting ice attacking the vessel, the stationkeeping capabilities of the AB are limited to operations requiring small changes in heading of the vessel in conjunction with small transitory motions in longitudinal direction of the vessel.

Propulsion Mode (Conventional Icebreaking): In this mode, the surrounding sheet ice is broken by the forces of the vessel generated by its propulsors and acting on the ice sheet.

Though the vessel is equipped with a great amount of ice capability in the longitudinal axis of the vessel (3 x 27,000 kW), the utilization of this power is limited. Icebreaking with the main propellers introduces forces in a longitudinal direction of the vessel, which may cause the vessel to move beyond its allowable limits determined by the specific type of DP operation (e.g., drilling).

The vessels capabilities in breaking ice in a stationary mode are limited by the capabilities (and performance) of the transverse thrusters.

Position Reference during Stationkeeping Operations in Ice

The conventional position reference system commonly applied for DP drilling operations in open water (acoustic, taut wire in the past) may not be applied for operation in ice. Acoustic systems require a deployment of hydrophones below the hull of the vessel and transponders on the sea floor. Both installations may be impractical for operations in sheet ice.

DGPS systems are of more practical use as position reference systems during operations in ice, if the reception of DGPS signals is reliable in Polar regions by the time the AB enters service.

Environmental Force Sensing and Prediction

During DP operations in ice, the advanced knowledge of the movement of the sheet ice (drift velocity and direction) is the predominant factor for the evaluation of the necessary counteractions, which must be generated by the vessel in order to stay within acceptable limits. The forces due to wind, current, and waves are irrelevant for most modes of operation. They are either not present (waves) or are retained by the ice (current, wind).

Prediction of the Sheet Ice Drift Angle and Velocity

Due to the enormous forces involved in making even small heading changes in stationary condition, advanced knowledge of changes in ice drift velocity and angle is mandatory for an efficient and safe operation.

GPS receivers/transmitters (disposable?) deployed by helicopters a distance of several miles from the vessel may be used to communicate with the vessel's GPS system to indicate changes of the ice relative to the position of the vessel.

Use of the DP System during Ice Operations

The vessel will be equipped with a DP system which will be able to automatically keep the vessel on station (or in other predefined modes, see below) in open water under specified operating conditions such as drilling, array towing and other scientific missions. The DP systems developed for this type of work became standard in the offshore industry. Hundreds of vessels perform daily operations in full automatic DP mode, including drill ships, which require great accuracy and extreme reliability while drilling for life high-pressure oil deposits in very deep water. However, the conditions for which these systems were developed are different in comparison with the conditions found during operations in solid, drifting ice sheets.

Experience with exploratory drilling in ice indicated that *automatic* dynamic positioning with the state-of-the-art DP systems is currently not feasible (emphasis on *automatic*). The forces acting on the vessel due to ice are erratic, and are of random nature. The forces acting on a vessel due to wind, waves, and current can be analytically determined and the response of the vessel can be calculated with a high degree of accuracy. This is not feasible with forces caused by ice. Unlike the forces e.g., due to wind, which can change - increase or decrease - rapidly in magnitude as well as direction, the forces due to ice change (typically) very slowly. The advanced knowledge of changes in velocity as well as direction of the ice drift by a system of DGPS receivers/transmitters (see above *Prediction of the Ice Sheet Drift Angle and Velocity*) allows timely counteraction to be implemented by inducing small changes in heading or small transitory motions of the vessel. We suggest controlling this action by manual input into the DP system via joystick. This control method is definitely feasible and safe.

STATIONKEEPING CAPABILITIES IN PROPULSION MODE

Scope

The following chapter presents the holding capabilities in *Propulsion Mode* of the AB for Stationkeeping in drifting, solid sheet ice.

A new approach had to be developed for the assessment of the holding capabilities in ice, whereas the assessment for the open water capability followed more conventional methods. The main goal of the analysis is to:

- Confirm the feasibility of holding the vessel's position and heading in ice
- Present the influence of the thruster power levels on the holding capability in ice

The investigation for the ice condition considered two representative ice thicknesses.

Ice Forces

The magnitude of the forces due to ice attacking the vessel during stationary operations were derived from model tests carried out in the ice tanks of Aker Arctic (AARC) in Helsinki and HSVA in Hamburg.

An intensive ice testing program was carried out at these facilities (12 days at AARC and 15 days at HSVA), including conventional tasks such as resistance and propulsion, wake measurements, maneuvering, sea keeping, transit ice breaking, etc. This paper focuses on the tests delivering data for stationkeeping in ice in propulsion mode. These include:

- Turning circle tests in solid ice sheets of 1.0 and 2.0 m thickness
- Oblique resistance tests in 1.0 m and 2.0 m solid ice sheets

Further tests included simulation of forced roll and pitch motions in 1.7 m solid ice sheets for the investigation of the icebreaking capabilities in the Vessel Motion Control Mode.

The results of the tests are published in Aker Arctic Report A-392 and HSVA Report TO 422-08, respectively. The stationkeeping calculations are based on the data from AARC for an ice thickness of 2.0 m, the HSVA data is applied for an ice thickness of 1.0 m. For both test series, only data from tests in oblique were applicable for the assessment of the holding capabilities.

The tests simulating forced pitch and roll motions delivered pertinent qualitative data.

The graphs *Ice Forces and Moments during Heading and Heading Changes* are presented below. They are based on the results of the model ice tests. The myriad amount of model test data were interpolated and simplified to establish a workable data platform.

For the stationkeeping in ice calculations, environmental forces such as wind or current were not considered. The influence of these forces is dwarfed by the magnitude of the ice forces.

Thrust Forces

The following thrust forces were introduced into the calculations for the optional thruster sizes:

POWER kW	THRUST (Effective Force) kN	PROPELLER DIAMETER m	PROPELLER RPM	PITCH/DIAMETER RATIO
3500	659	4.1	147	0.835
4500	797	4.1	147	0.939
5500	912	4.1	157	0.949
6400	1013	4.1	157	1.014

The contribution of the main propellers to the stationkeeping performance in ice was ignored. The (icebreaking) capability of the main propellers is far greater than ever needed to hold station. In addition, the emphasis of the analysis was placed on heading changes, which are executed by the transverse thrusters only.

Methodology

Objective

The objective of the stationkeeping in ice calculations is to determine the required thrust (respectively, the size (power) of the thrusters) in order to change the heading angle of the AB as a function of the time.

The method applied determines the equilibrium between the steady environmental forces and moments acting upon the vessel and the forces generated by the thrusters and main propellers.

Method of Calculation

A Thrust Allocation Algorithm was developed for the AB. This mathematical model allows the calculation of the required thrust forces as a function of the magnitude and incident angle of the environmental forces and moments.

The center of the drilling moon pool, was assumed the reference point for the DP system. Consequently, the moments of the external force and of the thruster forces were taken about this point as well.

The forces derived from the ice tests and listed in the spreadsheets/graphs *Ice Forces and Moments during Heading and Heading Changes* were introduced into a MathCAD calculation sheet. The results of the calculations indicate the thrust(s) required for the forward and aft thrusters, as well as the main propellers.

Due to the geometrical location of the thrusters and the location of the reference point in the aft of the vessels, all stationkeeping calculations indicate a low load for the aft thrusters and a high load for the forward thrusters. Consequently, the thrust required from the forward thruster(s) becomes the determining factor for the limitations of the stationkeeping capabilities and, subsequently, the primary issue for the selection of the size of the thrusters.

The contribution of the main propellers was disregarded due to the great amount of power available.

Only the thrust requirements for the forward thruster were introduced into the spreadsheet *Stationkeeping in Ice – Required Thruster Size*. These graphs indicate the approximate capabilities of the AB to change heading angles as a function of the transverse thruster size (in kW) and the thickness of the ice sheet as a parameter.

AURORA BOREALIS
Stationkeeping in Ice

SHEET 1 of 2

Ice Forces and Moments during Heading and Heading Changes

	t_{ICE}	Incident angle	FX	FY	MZ/10
	m	Deg.	Kn	kN	kN*m
HSVA	1.0	0	2100	0	0
	1.0	10	2100	4700	6700
AARC	2.0	0	2100	0	0
	2.0	10	2100	10000	22000

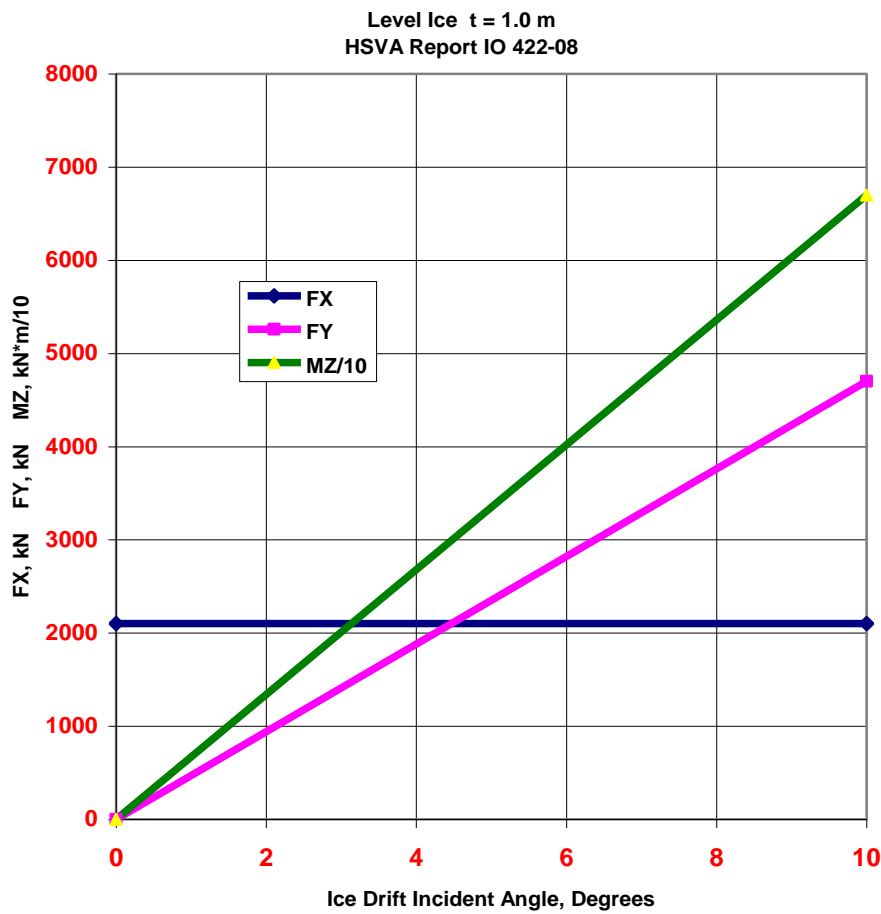

NOTES

- 1 AARC test values were corrected to comply with HSVA test methods
- 2 Some AARC and HSVA values were adjusted to represent realistic and average values

AURORA BOREALIS
Stationkeeping in Ice

SHEET 2 of 2

Ice Forces and Moments during Heading and Heading Changes

	t _{ICE}	Incident angle	FX	FY	MZ/10
	m	Deg.	Kn	kN	kN*m
HSVA	1.0	0	2100	0	0
	1.0	10	2100	4700	6700
AARC	2.0	0	2100	0	0
	2.0	10	2100	10000	22000



Level ICE t = 2.0 m
AARC Report A-392

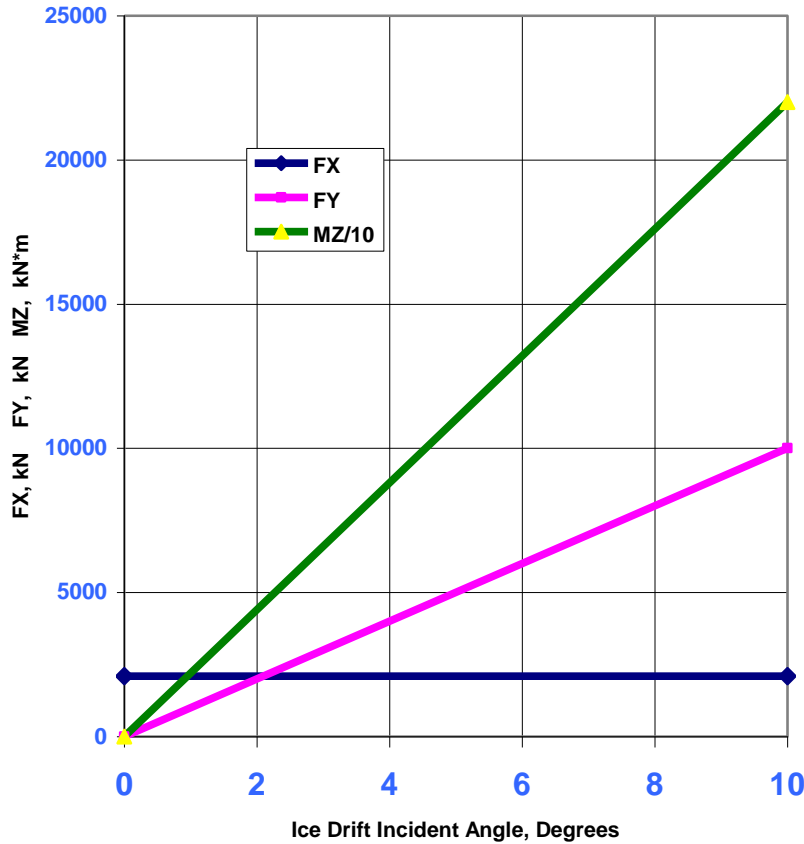

NOTES

- 1 AARC test values were corrected to comply with HSVA test methods
- 2 Some AARC and HSVA values were adjusted to represent realistic and average values

Stationkeeping in Ice Required Thruster Size

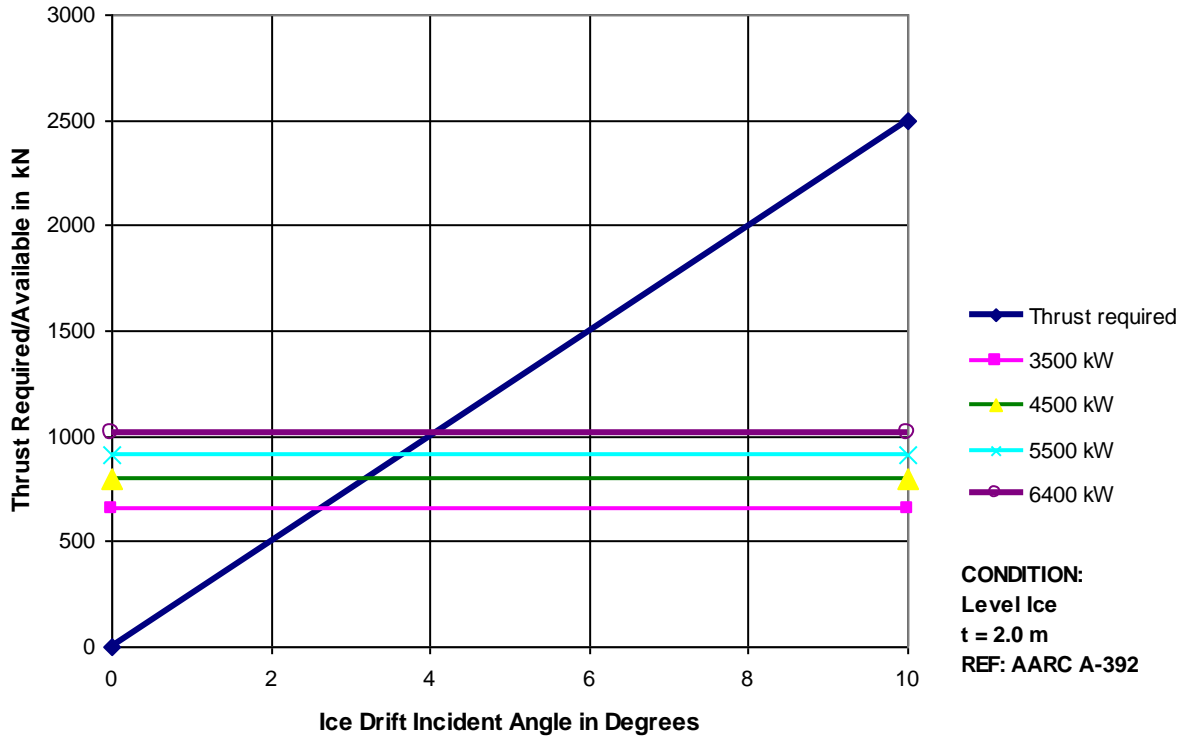

CONDITION:
Level Ice
t = 2.0 m
REF: AARC A-392

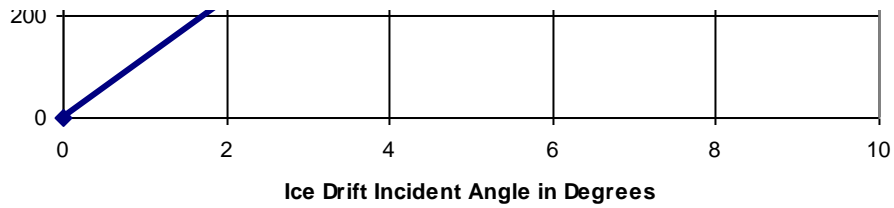

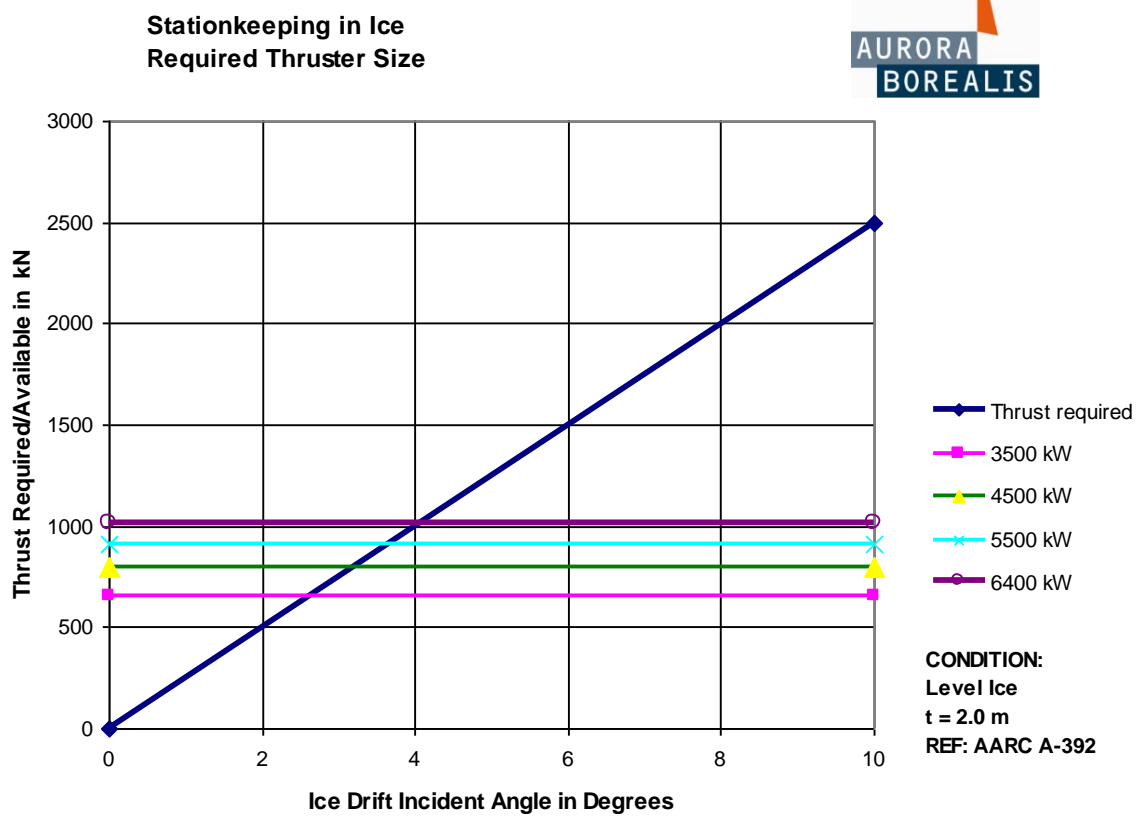

Discussion of the Results

1 Level Ice $t = 1.0$ m

The graph: **Stationkeeping in Ice, Required Thrusters Size**
Condition: Level Ice $t = 1.0$ m indicates the following results:

Required Thruster Power (Size) kW	Ice Drift Incident Angle (Degrees)
3500	5.7
4500	7.0
5500	7.9
6400	8.8

2 Level Ice $t = 2.0$ m

The graph: **Stationkeeping in Ice, Required Thrusters Size**
Condition: Level Ice $t = 2.0$ m indicates the following results:

Required Thruster Power (Size) kW	Ice Drift Incident Angle (Degrees)
3500	2.7
4500	3.2
5500	3.6
6400	4.0

The tables indicate the thruster power (size) required for the vessel in order to be able to execute yaw maneuvers for heading changes against an ice incident angle.

Example:

4500 kW Thruster: In 1.0 m ice, the vessel is able to change (control) heading up to an ice drift incident angle of 7.0 degrees.

In 2.0 m ice, the vessel is able to change (control) heading up to an ice drift incident angle of 3.2 degrees.

Conclusion: An advance warning/measuring system for ice drift changes is of great importance for the efficient stationkeeping operation in ice for the AB.

Summary

The stationkeeping capabilities of the vessel in propulsion mode can be summarized as follows:

- In longitudinal (X-) direction, the forces available from the main propellers are far greater as required considering the drift forces and velocities of sheet ice of 1.0 to 2.0 m thickness. However, applying the main propellers during stationkeeping in ice may result in overshooting the target point and require instant position corrections. These may cause a heavy strain on the propulsion machinery.
- In transverse (Y-) direction, the drift ice forces are far greater than any installation of propulsive power could accomplish.
- Heading corrections can be carried out as indicated in the above graphs. The degree of heading change capability is a function of the power available (size) of the transverse thrusters. As mentioned earlier, an advanced warning system for ice drift heading (as well as velocity) changes is essential for an efficient and safe stationkeeping operations of the vessel.
- An extensive trial program must be implemented to familiarize the operating personnel with the problems and limitations associated with stationkeeping in solid, drifting sheet ice.

STATIONKEEPING CAPABILITIES IN VESSEL MOTION CONTROL MODE

In addition to the icebreaking features of the AB generated by its propulsors, the vessel is equipped with a unique Motion Control System. This system allows icebreaking in stationary mode without longitudinal or transverse displacement or motions of the vessel.

¹The system induces forced roll and pitching motions of the vessel. These motions, together with the exclusive hull shape, facilitate breaking of ice in longitudinal as well as in transverse direction while the vessel is stationary².

Model Tests

An extensive test program was carried out at the HSVA ice tank in order to verify the validity of the assumption and expectation of the designers.

¹ WSDG applied for international patents for the technology of breaking ice in stationary mode by controlling the roll and pitch motions of a vessel.

² These features are not considered in the above stationkeeping calculations. These calculations are solely based on the results from the tests in solid sheet ice.

For the simulation of the roll motions, the model was equipped with a weight attached to a linear motion motor. This weight moved in controllable frequency on the deck of the model in transverse direction, thus introducing roll motions onto the model.

The pitching motions were simulated in a simpler manner: A weight was lifted and lowered by a crane in the desired frequency onto the bow of the model (see pictures below).

The forced harmonic roll and pitch tests were carried out in an ice thickness of 1.8 m (equivalent).

The tests clearly demonstrated that icebreaking with forced harmonic rolling and pitching of the vessel is feasible with practically zero forward motion. Due to the motions of the vessel the friction between ice and the hull is dynamic instead of static and is therefore lower. Induced motions also improve the capabilities during conventional icebreaking.

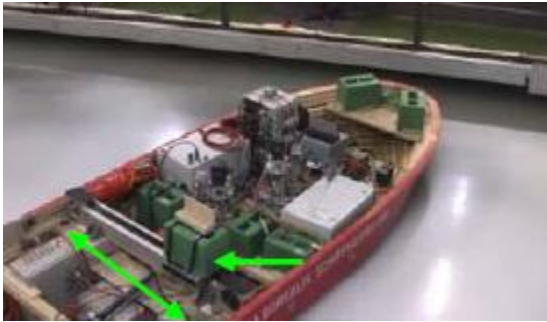

Simulation of Roll Motions



Simulation of Pitch Motions

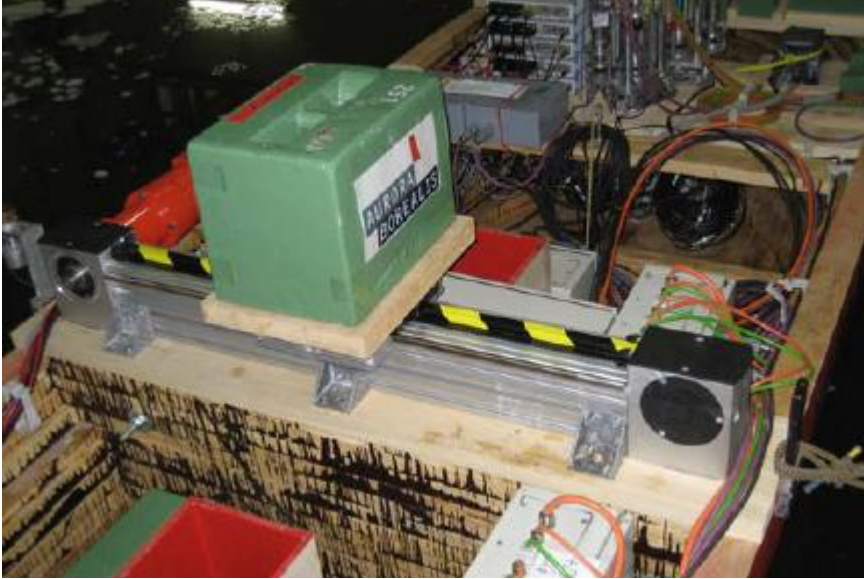

Simulation of Roll Motions: Linear Motion Motor Arrangement and Weight (green color)

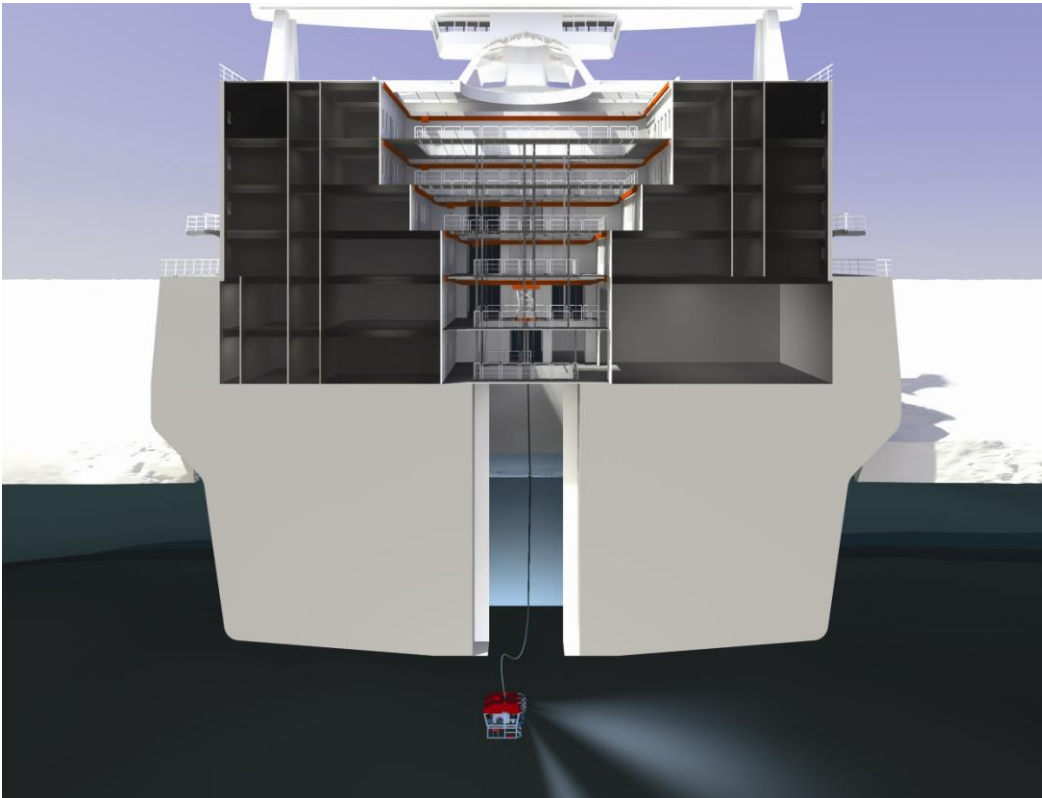

AB section at scientific moon pool, showing the shape of the hull designed for icebreaking in transverse direction.

Roll Motion System

WSDG introduced two design features intended to facilitate breaking of ice in transverse direction:

- A shape of the midship section which allows breaking of ice while the vessel is subjected to roll motions
- A tank system which allows forced, harmonic roll motions

The roll (heeling) tank system consists of two pairs of tanks, each pair connected with ducts (see below). Seawater is pumped from one tank to the other in 60 to 100 seconds per cycle to achieve a heeling angle between 3 and 5 degrees. The maximum roll angle of 5 degree is determined by the side shoulder slope of the vessel.

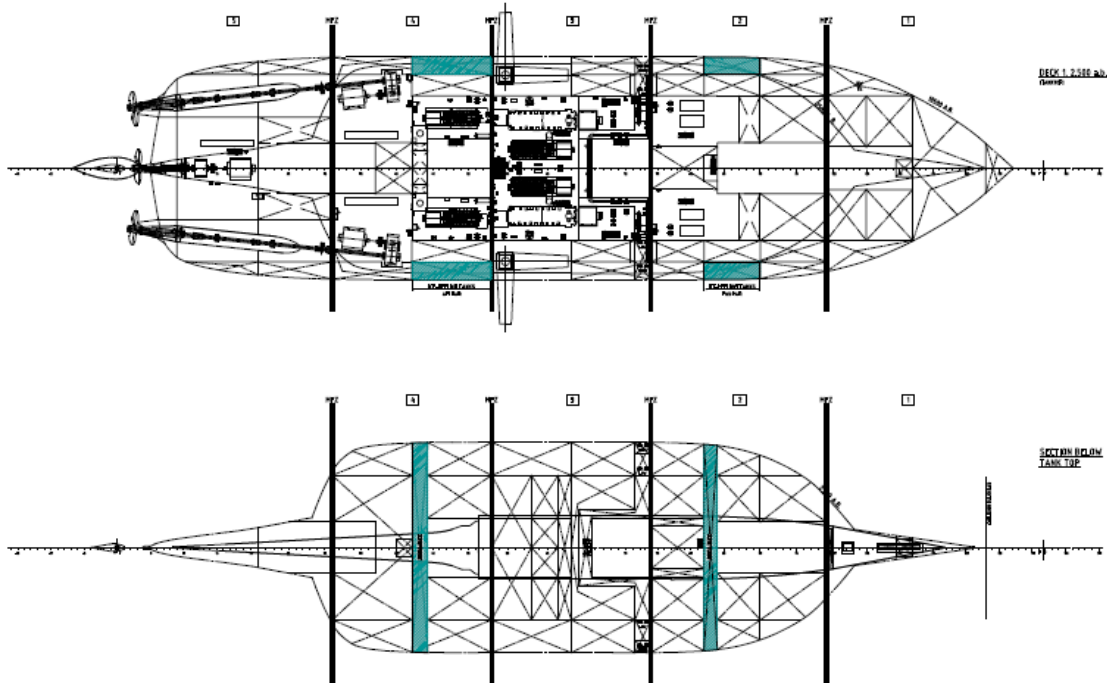

Pitching Motion System

This system forces pitching motions on the bow and stern of the vessel. The motions are capable of forcing the ice to break while the vessel is in stationary mode.

A principal arrangement of the system is shown below. The system is capable of moving 2x750 tons of water in 19 seconds (maximum) from tanks in the stern to tanks in the bow of the vessel. Approximately 2x3000 kW axial flow pumps with controllable pitch

impellers are required to accelerate and decelerate the amount of water in the required frequency.

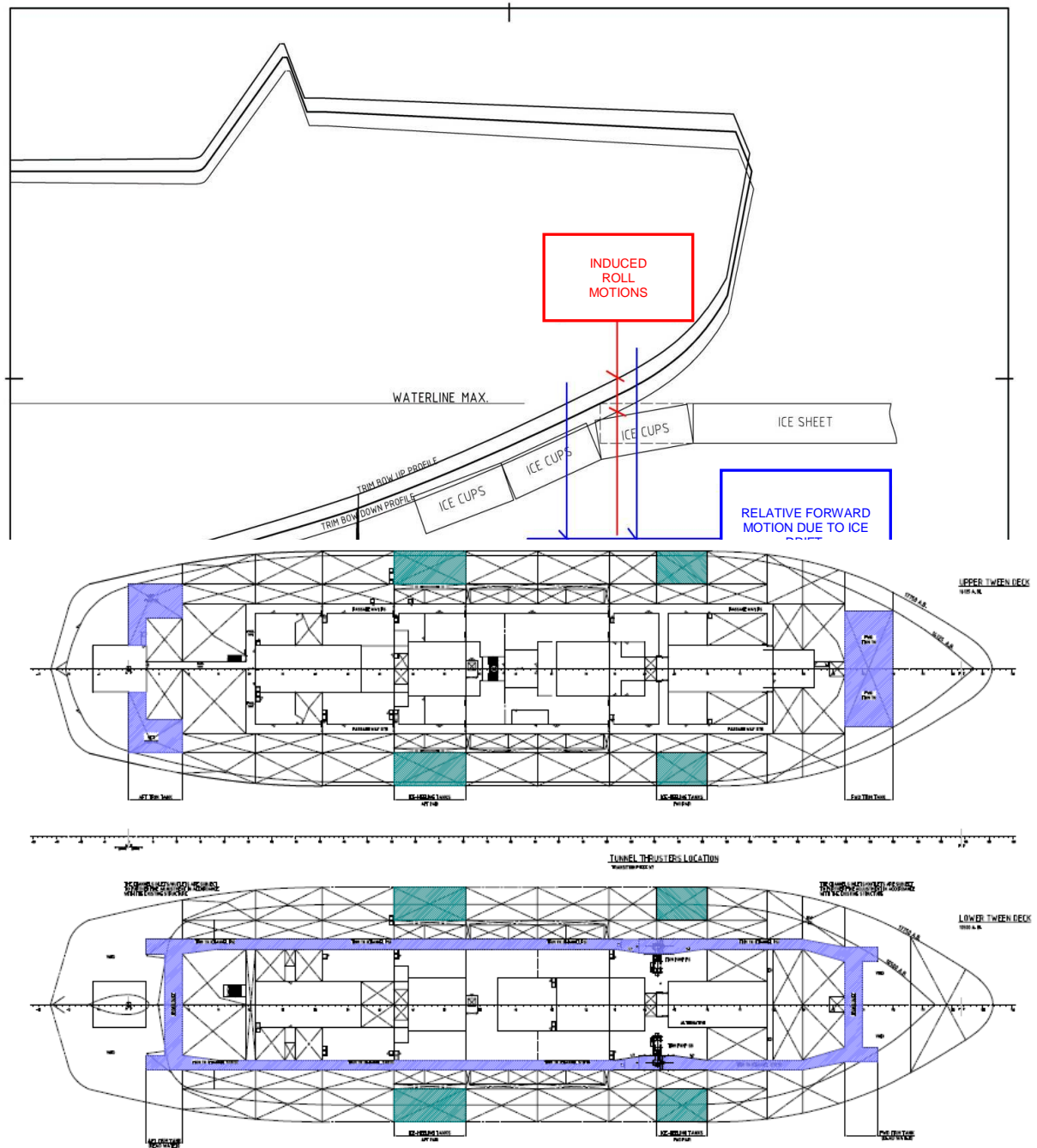

CONCLUSION

- The AURORA BOREALIS is capable of keeping station in solid, drifting ice sheets.

- Two separate techniques can be applied during stationkeeping in this condition:
 - Propulsion Mode
 - Motion Management Mode
- The model tests indicate limits at approximately 2.0+ m ice thickness. The exact limitations of the capabilities have to be determined during trials.
- A further improvement should be feasible by combining the two modes.
- The control mode anticipated during stationkeeping in ice is DP – Joystick control
- Operation of the transverse thrusters: The model tests indicate occasional blocking of a nozzles with big chunks of ice. Instant, short-time reversal of the sense of propeller rotation should blast the ice from the nozzle.
- The operation of all propellers should be continuously monitored and visually observed. The control of the thrusters and main propellers should be prepared to allow a manual override for one particular propeller to counteract ice blocking. We consider this feature essential for an efficient and safe operation.

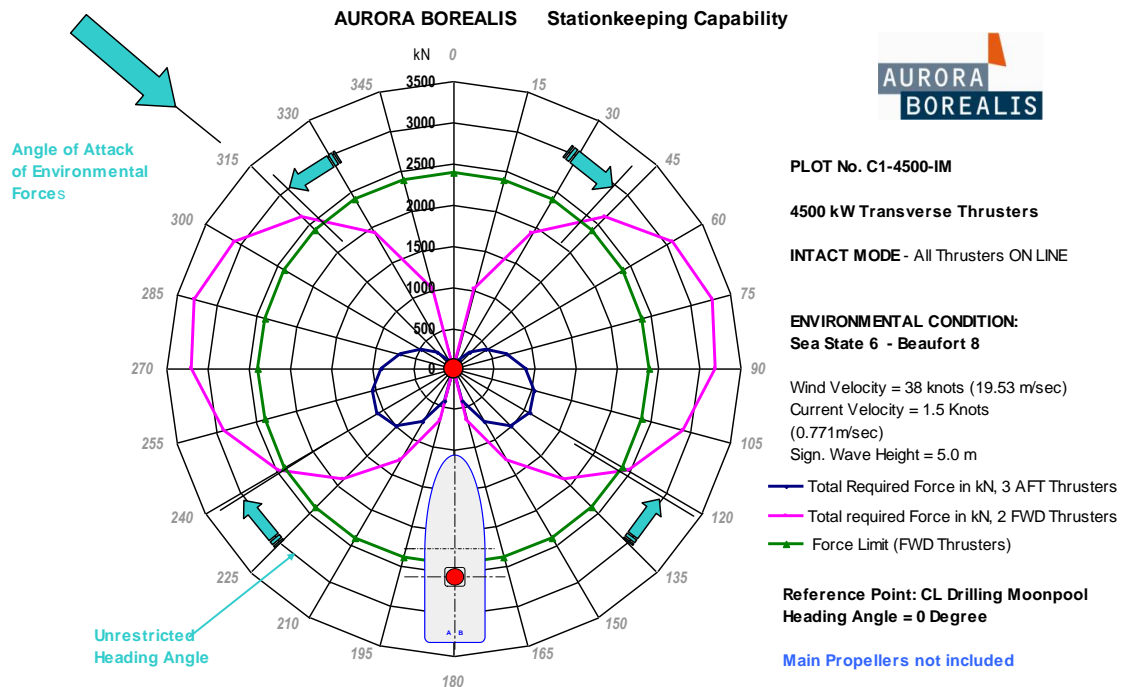

Sample Polar Plot for Stationkeeping in Open Water
 4500 kW Thruster, Intact Mode

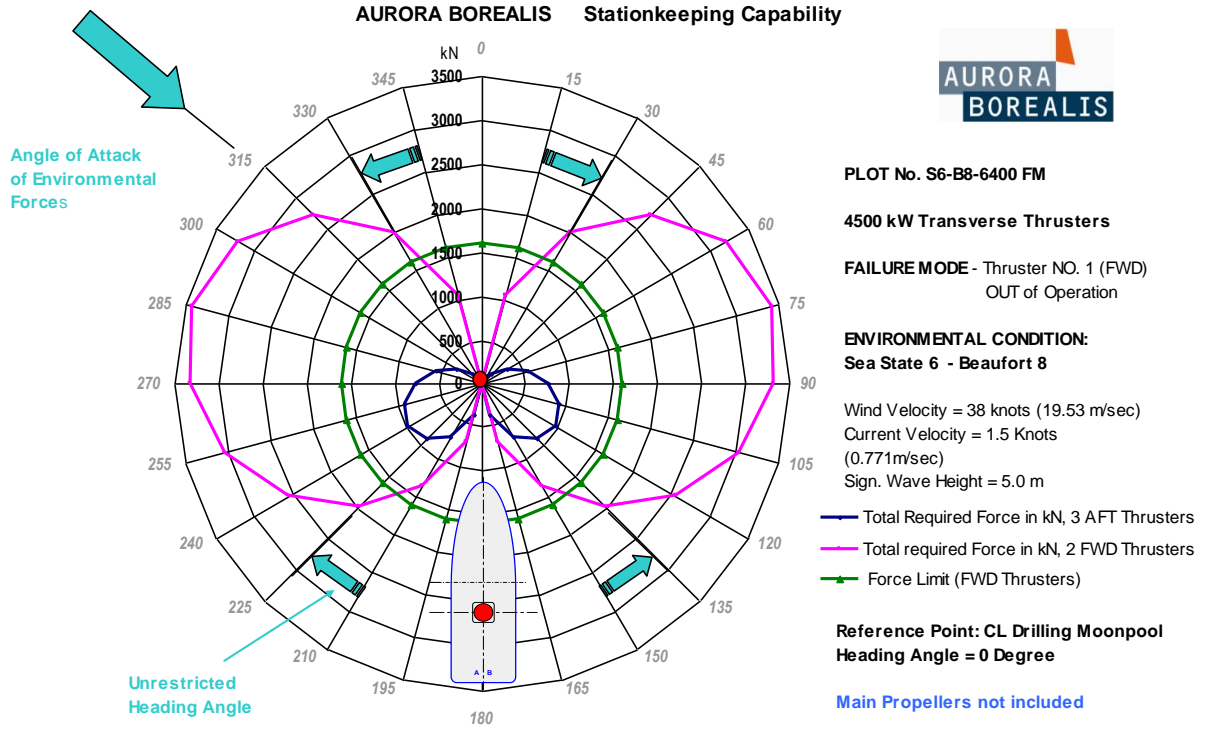

Sample Polar Plot for Stationkeeping in Open Water
4500 kW Thruster, Failure Mode