



## **DYNAMIC POSITIONING CONFERENCE**

**October 13-14, 2009**

**New Applications**

---

### **Close-In Precision DP using Wave Feed Forward: STLVAST Phase 2 & 3**

**Dr. Greg Hughes**

*Oceaneering International Inc. (Hanover, MD)*

**Dr. Rick Harris**

*MAPC (Baltimore, MD)*

**Ir. Frans Quadvlieg**

*MARIN (Wageningen, The Netherlands)*

**Ir. Rink Hallmann**

---

## ABSTRACT

Following from last year's presentation [1], the STLVAST team will discuss the development of an innovative method of improving DP positioning accuracy using only sensors and control algorithms. Based on the estimation of wave drift forces using wave height sensing and the application of a wave feedforward control loop, the positioning of a vessel in a seaway is improved. This technique is also applied to the challenge of controlling two large vessels, running alongside, at ahead speeds. This work is funded by the US Navy Office of Naval Research.

## WHY DO WE NEED TO SAFELY DRIVE TWO SHIPS AT 4 KNOTS, 25 FEET APART?

The quick answer to this is because the US Navy (USN) has a vision to supply humanitarian aid or project military power, without the use of any traditional port or shore based facilities. However troops, equipment and supplies must still be delivered ashore, and so a "port at sea", the sea base, is required. In turn the sea base therefore requires this logistic transfer to occur between large vessels, at sea, underway and in higher sea states, and from these operational needs flows the requirement for Close-In Precision Dynamic Positioning (CIP DP).

The goal of the Office of Naval Research (ONR) is to "foster, plan, facilitate and transition scientific research in recognition of its paramount importance to enable future naval power and the preservation of national security." To this end, ONR invests in several areas of Science and Technology, including Discovery and Invention (D&I), Future Naval Capabilities (FNC) and Innovative Naval Prototypes (INP). STLVAST (Small to Large Vessel At-Sea Transfer) is an FNC. FNCs generally start with a Technology Readiness Level (TRL) of 3 or 4 (proof of concept to component validation in a laboratory environment) and are transitioned to an acquisition program office at a TRL of 6 (demonstration in a relevant environment).

FNCs are aligned with the pillars identified in Seapower 21, the Navy's top level vision document and a couple cross-cutting focus areas. The pillars include Sea Shield, Sea Strike, Seabasing, and FORCENet,. The STLVAST program supports the Navy's Seabasing pillar. The Seabasing Concept addresses the following tasks, typically referred to as CAESaR:

- Close a Marine Expeditionary Brigade-sized force within 10-14 days
- Assemble a Marine Expeditionary Brigade-sized force within 24-72 Hours
- Employ one battalion vertically and one battalion via surface within 8-10 hours
- Sustain selected joint forces and up to two brigades operating up to 150 nm inland with minimal logistics footprint ashore
- Reconstitute forces for future operations within 30 days

Three of the above tasks (assembling, sustaining, and reconstituting) require the at-sea transfer of personnel, vehicles, and break bulk / containerized cargo to enable transfer to / from surface connectors. This at-sea transfer will bring ships much closer than previously required (due to reach limits of the transfer crane), and Close-In Precision Dynamic Positioning (CIP DP) is a key technology needed to successfully position two ships as close as 25 to 15 feet for transfer operations while moving forward in the seaway.

## STLVAST REQUIREMENTS AND CONSTRAINTS

Therefore an increase in dynamic positioning capability is required by seabasing and the STLVAST project through consecutive Task Orders has sought to investigate, develop and test innovative concepts to provide this capability. Task Order 1 experimented with increasing the bandwidth of the thruster architecture, a significant improvement in DP capability in higher sea states, alongside and at high speeds was demonstrated in the test tank, and this was the subject of our paper at this conference last year.

In Task Order 2 and 3 we have gone back to the drawing board and attempted to provide an improved DP capability without changing the thruster architecture, i.e. can we increase the performance of a DP system based on azimuthing thrusters using only sensors and control algorithms. As our capability constraints have increased so our operational requirements have changed, and now we must consider the following:

- Vessel Separation from 32.5m to touching fenders (no lines allowed)
- Sea States from SS3 and SS4, from multiple directions, the active DP vessel in the lee or to weather of the cargo vessel
- Ahead speeds from 0 knots (a drifting container ship) to 4 knots
- Approach and Breakaway in all combinations of the above

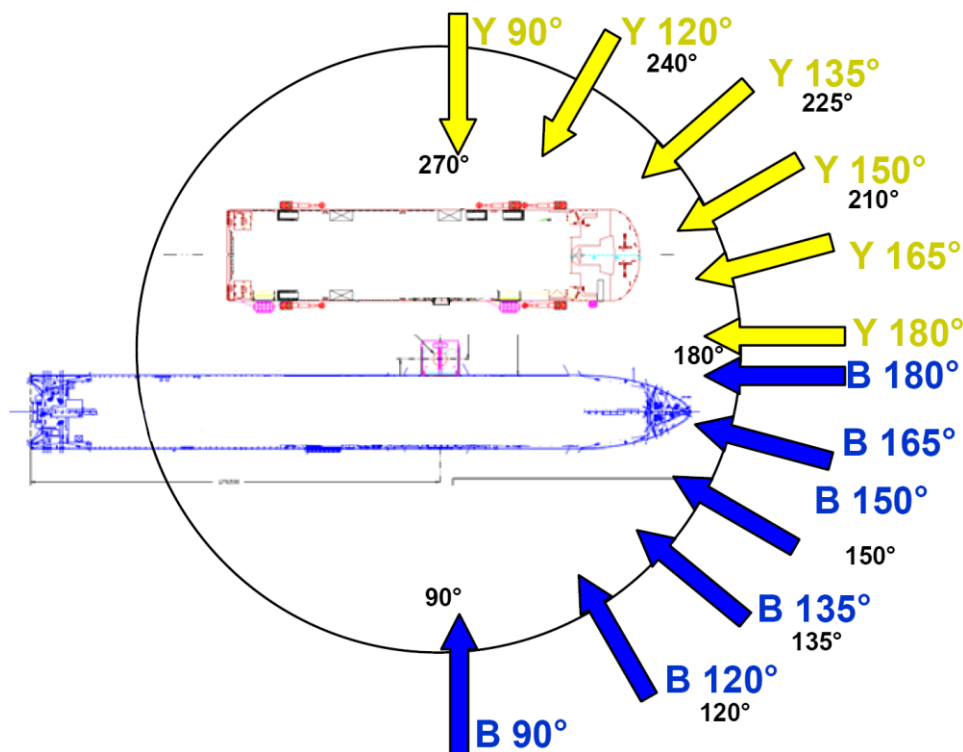

**Figure 1: Definition of wave directions with Mighty Servant 3 on lee and on weather side**

These many requirements can best be summarized by developing two conceptual solutions, the first using technologies described in this paper, is to attempt to improve the performance of the DP system at separations greater than a fendered distance, out to 32.5m; the second is to improve

positioning performance whilst alongside and in contact with the fenders, and these solutions are not discussed in this paper. Two vessels have been identified to allow the development and testing of technology. These vessels are the Dockwise Mighty Servant 3 (MS3) and a Large Medium Speed Roll-On/Roll-Off (LMSR) ship, both are modeled in the MARIN test tank at a scale of 1:30.15 and both are involved in a full scale sea trial in early 2010.

The STLVAST CIP-DP operating scenario differs from typical DP applications in several important respects. The first difference concerns the relevant environmental disturbances. The addition of a second ship creates wave diffraction and “bank effect” hydrodynamic loads and in addition ahead speed increases sway/yaw coupling of the maneuvering ship. The presence of a second ship also modifies the wind flow and corresponding loads, although these effects were not considered in the present study. Ship positioning requirements are tighter and more critical due to the close separations. Furthermore, ahead ship speeds can dramatically reduce the effectiveness of typical DP thrusters.

### SOME FUNDAMENTAL ASPECTS OF FEEDBACK/FEEDFORWARD CONTROL

Ship dynamic positioning systems use thrusters to maintain the position of a ship with respect to some other object in the presence of external disturbances such as wind, waves, and mooring devices. Typically both feedback and feedforward control elements are employed. In feedback control the actual state of the system is measured, compared to the commanded state, and the error is used in various ways to determine the appropriate actuator response. The advantage of feedback control is that it does not require accurate knowledge of the disturbances to the system, but the disadvantage is that an error between the desired and actual state of the system must accumulate for the control system to take action.

Feedforward is fundamentally different in that it directly responds to a disturbance without measured error of the desired state. The advantage is that it can counter the influence of a disturbance to the system directly and does not require errors to accumulate. The disadvantage is that it requires an accurate estimation of the disturbance in order to use the actuators properly.

Since both feedback and feedforward control have complementary strengths and weaknesses, a powerful technique for dynamic positioning systems is to combine feedback and feedforward elements. The feedforward elements address disturbances that can be measured or estimated well and feedback handles the rest, including inaccuracies in the feedforward control. This combined feedback/feedforward approach is used with all modern dynamic positioning systems.

Some insight into the advantages and limitations of feedforward control can be explored by considering the simplified block diagram of a typical position control system shown in Figure 2. In this system only one degree of freedom is considered. Three system inputs are shown, the commanded position  $Y_c(s)$ , external disturbances  $d(s)$ , and the feedforward measurement noise  $m(s)$ . Since we are mainly interested in comparing feedback and feedforward control, position filtering and measurement noise are ignored. One output is defined, the actual position  $Y(s)$ . Four transfer functions characterize the system dynamics including the feedback compensation  $K(s)$ , feedforward compensation  $F(s)$ , thruster dynamics  $T(s)$ , and the ship sway dynamics  $S(s)$ .

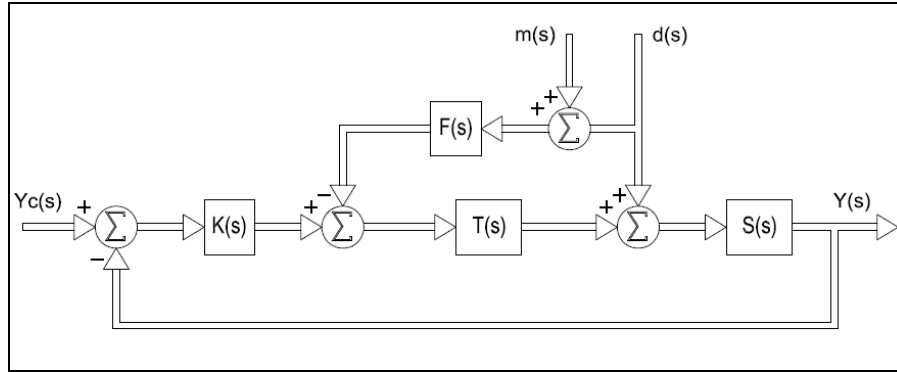

**Figure 2: Basic DP system block diagram**

The transfer functions relating the output and commanded input is therefore.

$$\frac{Y(s)}{Yc(s)} = \frac{S(s)T(s)K(s)}{1 + S(s)T(s)K(s)}$$

While the transfer functions relating the output to the external disturbance and feedforward measurement noise are:

$$\frac{Y(s)}{d(s)} = \frac{S(s)[1 - T(s)F(s)]}{1 + S(s)T(s)K(s)} \quad \frac{Y(s)}{m(s)} = \frac{-S(s)T(s)F(s)}{1 + S(s)T(s)K(s)}$$

Providing good command tracking and disturbance rejection then boils down to making the first transfer function equal to one over the range of desired frequencies and making the second two transfer functions as small as possible. Accomplishing all of these goals perfectly is not possible however. The loop gain on  $Y(s)/Yc(s)$  is limited by stability margins linked to ultimately to actuator bandwidth and saturation and the desire to not overwork the thrusters. It also appears that perfect rejection of the external disturbances can be achieved if only the product  $T(s)F(s)$  can be made equal to one. But both the actuator dynamics and feedforward compensation are by necessity strictly proper transfer functions which cannot cancel perfectly, so we can only hope to achieve cancellation over a limited range of frequencies. It is worth noting however that the upper bound of this range of frequencies is the bandwidth of the actuator transfer function  $T(s)$ , not the loop bandwidth which must be lower than the actuator bandwidth to preserve closed loop stability margins. This therefore admits the possibility of rejecting disturbances over a broader range of frequencies than would be possible with just feedback control. This result is of fundamental importance because disturbance rejection bandwidth can be increased without upgraded thrusters or reduced stability margins resulting from simply increasing feedback gains.

Finally it should be noted that feedforward control requires accurate estimation of the disturbances to work. For example, if the product  $T(s)F(s)$  is equal to 1, then the transfer function  $Y(s)/m(s)$  has exactly the same form as  $-Y(s)/d(s)$  without feedforward activated (i.e.  $F(s) = 0$ ). Thus all external disturbance measurement errors will influence the position just as if they were actual disturbances. It is also important to note that the feedforward compensation does not influence the transfer function  $Y(s)/Yc(s)$  and therefore cannot improve command tracking.

Feedforward compensation design thus requires balancing these tradeoffs. The main requirement is a robust method for measuring relevant disturbances which limits noise and provides sufficient bandwidth to enable the feedforward compensation  $F(s)$  to be selected such that the numerator of  $Y(s)/d(s)$  can be canceled over the frequency range of the external disturbances as permitted by the thruster bandwidth.

Therefore one of the major goals of the STLVAST wave feedforward campaign was to develop a sufficiently accurate method for estimating wave disturbances. The requirements for the method were that it measures the disturbances of interest and measure them over a sufficient range of frequencies to realize the potential benefits of feedforward control.

### WAVE DISTURBANCES

Wave disturbances to a floating vessel can be divided into two categories. The first are “first order” wave disturbances which are proportional to wave amplitude and occur at the wave encounter frequency. These loads create large oscillatory, zero-mean motions which cannot be attenuated by the thrusters used for dynamic positioning. Physically they result from linear pressure variations due to the incident wave field, hydrostatic restoring forces, added mass, and damping effects associated with the radiation of free surface waves.

The second category of disturbances are the “second order” disturbances which are proportional to the square of wave amplitude, occur at frequencies below the encounter frequency of the waves, and are non-zero mean. These loads are typically several orders of magnitude smaller than the first order loads so their influence can be mitigated by modestly sized actuators. But it is important to note that they can cause large position errors because both linear and quadratic damping of surface vessel planar motions becomes vanishingly small at low frequencies.

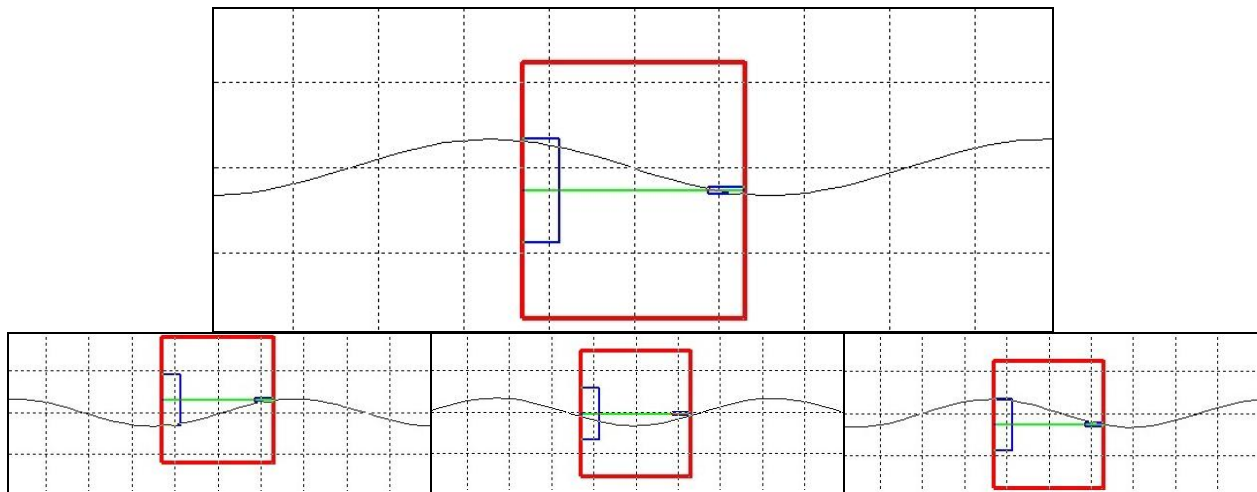

**Figure 3: Difference in Wave/Hull Contact Line Near Heave Resonance**

Physically, second order wave disturbances result primarily from the quadratic terms in Bernoulli’s equation, the relative phasing of hull motions and incident waves, and wave diffraction. The phasing effects are dominant for wave frequencies near pitch and heave

resonance while diffraction effects are dominant for higher frequency waves. Figure 3 illustrates the dramatic difference between the maximum and minimum wave/hull contact line for a heaving 2-D cylinder near heave resonance.

### THE PINKSTER WATERLINE INTEGRAL METHOD

The STLVAST program adopted a technique originally proposed by J. Pinkster and colleagues and MARIN and T.U. Delft [2] to provide wave disturbance measurements for the wave feed forward system. This approach, which we refer to as the Pinkster waterline integral method, is based on an analysis of the unsteady potential flow about a structure floating in waves. An orderly series expansion of the potential function and resulting ship motions is used to identify terms of second order. The main result is that the second order wave loads can be calculated as the sum of four individual components (in deep water).

- I – Waterline integral of relative wave height squared
- II – Surface integral of quadratic term of Bernoulli’s equation
- III – Product of the first order body translations and first order pressure
- IV – Product of the first order body rotations and the first order forces

The four contributions and their relative magnitude as a function of frequency is illustrated in Figure 4 which is drawn from [2].

A wave drift load estimation scheme can be based on two observations. First, the waterline integral (term I) is dominant and has the same “shape” as the total disturbance. Thus, by using tuning “factors” it may be possible to relate the waterline integral to total drift load by simply scaling it. The second observation is that the waterline integral can be calculated in real time from relative waterline measurements. In fact all published work on wave feedforward control is based on exploiting this result by using the persistent measurement of the relative wave height at various stations around a ship to predict second order wave loads.

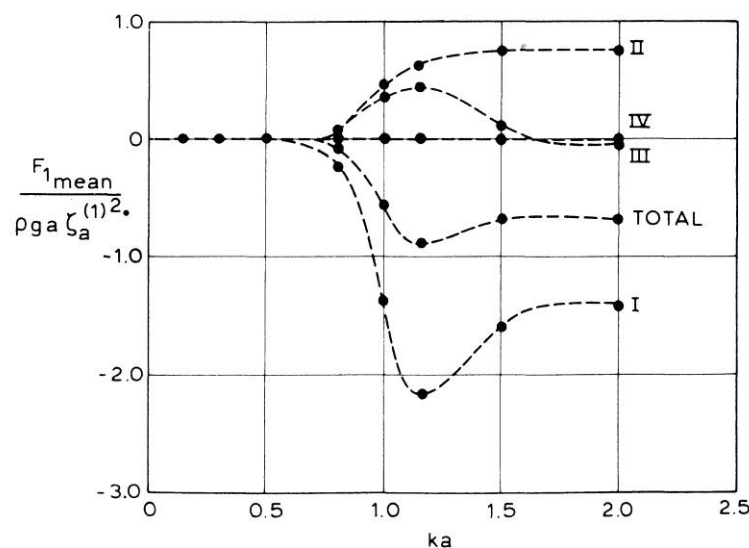

**Figure 4: Second Order Wave Load Components**

The STLVASt CIP-DP wave feedforward effort is based on investigating this method of predicting the second order wave disturbances as will be described in later sections.

### PROVING WAVE FEEDFORWARD WORKS IN THE TANK

To summarize, a dynamic positioned vessel is moved from its required position due to wind, current or waves. To improve the dynamic positioning and tracking capabilities of a vessel, the actual wave forces can be approximated and be counteracted before these forces result in a deviation from the required position. This counteracting of instantaneously measured excitation forces is called feedforward in dynamic positioning terminology. Second order wave forces contain mainly mean and low frequency components. The low frequency components are associated with the frequencies of wave groups occurring in irregular waves. These low frequency components are however very important because their period may very well coincide with the natural period of the DP system.

Two setups were used to study and demonstrate the DP performance increase due to wave feedforward. The Mighty Servant 3 and the Transshelf (two vessels operated by Dockwise B.V.) were both tested. Since the objective was to demonstrate whether wave feedforward would work, three rounds of tests were conducted:

- The first round was a test series demonstrating that it would be possible to measure the waves around the vessel and correlate them with measured wave drift forces. For this test campaign, a model of the Transshelf was equipped with 20 wave probes equally distributed around the vessel. These wave probes were able to measure the local relative wave height. Figure 5 illustrates tests carried out with the vessel. At the same time that on-line, the relative wave heights were recorded, the second order wave drift forces were measured by force transducers in a soft spring arrangement.
- The second test round was the application of WFF in a control loop on the Transshelf vessel. The vessel was also equipped with the relative wave height sensors, but now the DP computer controlled the vessel(s).
- The third test round was the application of WFF on a new ship: the Mighty Servant 3, also a Dockwise vessel. An application on a new ship (though of roughly the same dimensions) is an independent assessment on whether 'it works'. Again, Mighty Servant 3 was equipped with relative wave height sensors and fully active relative DP computers, similar to Transshelf.

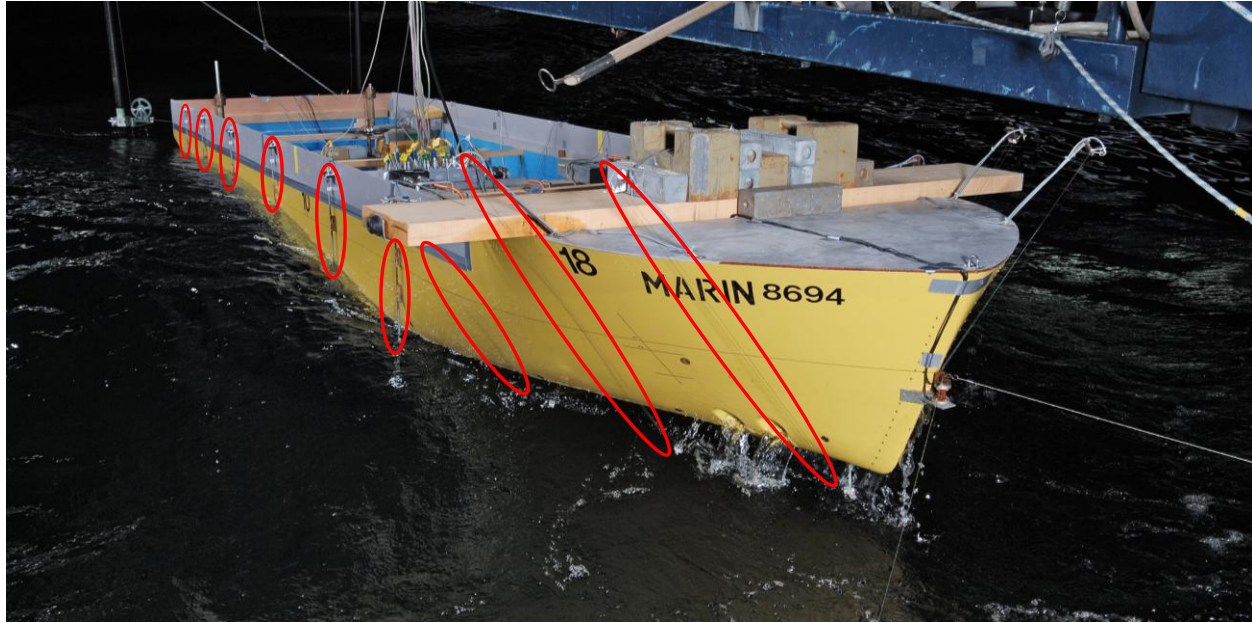

**Figure 5: Transshelf equipped with 20 wave probes around the vessel to correlate measured wave forces with local wave height measurements**

The first test series demonstrated that using these relative wave height sensors, the wave drift forces can be computed on-line. This was demonstrated for zero speed and forward speed, and for Transshelf alone, and also for Transshelf in close proximity of another ship. This was unique: in the past, the technical literature has demonstrated a capability for only a single ship, and at zero speed (see reference [2], [3], [4] and [5]). Whether these techniques would be feasible at forward speed and in close proximity was a new challenge.

From these tests, it was concluded that tuning factors would be necessary to transform the relative wave height measurements to the second order wave drift forces. For DP positioning purposes only the mean and low frequency second order wave forces are of interest. To obtain these, the squared wave elevation  $\zeta$  was filtered with a low pass filter:

$$X_{w_{\text{Mean+LF}}} \approx -C_1 \cdot \frac{1}{2} \cdot \rho \cdot g \cdot \sum_{j=1}^n \left\{ \left( \zeta_{r,j}^{(1)} \right)_{\text{Mean+LF}}^2 \cdot n_{x,j} \cdot L_j \right\}$$

$$Y_{w_{\text{Mean+LF}}} \approx -C_2 \cdot \frac{1}{2} \cdot \rho \cdot g \cdot \sum_{j=1}^n \left\{ \left( \zeta_{r,j}^{(1)} \right)_{\text{Mean+LF}}^2 \cdot n_{y,j} \cdot L_j \right\}$$

$$N_{w_{\text{Mean+LF}}} \approx -C_3 \cdot \frac{1}{2} \cdot \rho \cdot g \cdot \sum_{j=1}^n \left\{ \left( \zeta_{r,j}^{(1)} \right)_{\text{Mean+LF}}^2 \cdot (x_{x,j} \cdot n_{y,j} - x_{y,j} \cdot n_{x,j}) \cdot L_j \right\}$$

Where  $n$  is the number of relative wave height sensors,  $L_j$  is the length of the waterline element,  $n_{xj}$  and  $n_{yj}$  is the surface normal in respectively the  $x$  and  $y$  direction and  $x_{xj}$  and  $x_{yj}$  are the locations of each  $j^{\text{th}}$  wave sensor.  $C_1$ ,  $C_2$  and  $C_3$  are the correction factors. It should be noted that

this relatively simple formula is an approximation of the wave forces. However this very simplicity is a great strength in the practical application of the method.

It was extremely important that the low pass filter should not introduce any delays. Delays are very undesirable in any control loop. Furthermore, the applied filter has an influence on the optimum correction factors  $C_1$ ,  $C_2$  and  $C_3$ .

Ultimately an “alpha-beta tracker” was selected as this seemed the most optimum filter that did not introduce any significant delays.

$$F_{\text{wave}}(k) = F_{\text{w,pred}}(k) + \alpha \cdot (F_{\text{waterline}}(k) - F_{\text{w,pred}}(k))$$

$$\frac{dF_{\text{wave}}}{dt}(k) = \frac{dF_{\text{wave}}}{dt}(k-1) + \beta \cdot (F_{\text{waterline}}(k) - F_{\text{w,pred}}(k)) / \Delta t$$

$$F_{\text{w,pred}}(k+1) = F_{\text{wave}}(k) + \frac{dF_{\text{wave}}}{dt}(k) \cdot \Delta t$$

The second and the third test series: After the successful determination of the correct formulations to use, the next step was to include this in a DP control loop. In addition as the operational objective was to support ‘seabasing’, tests included different environmental conditions at zero speed, forward speed and for a ship alone and for ships in close proximity under relative DP as well. Figure 6 shows the control loop which is designed for the ship with Wave FeedForward. During the model tests, this is how the ship was actually controlled by computers during the model tests.

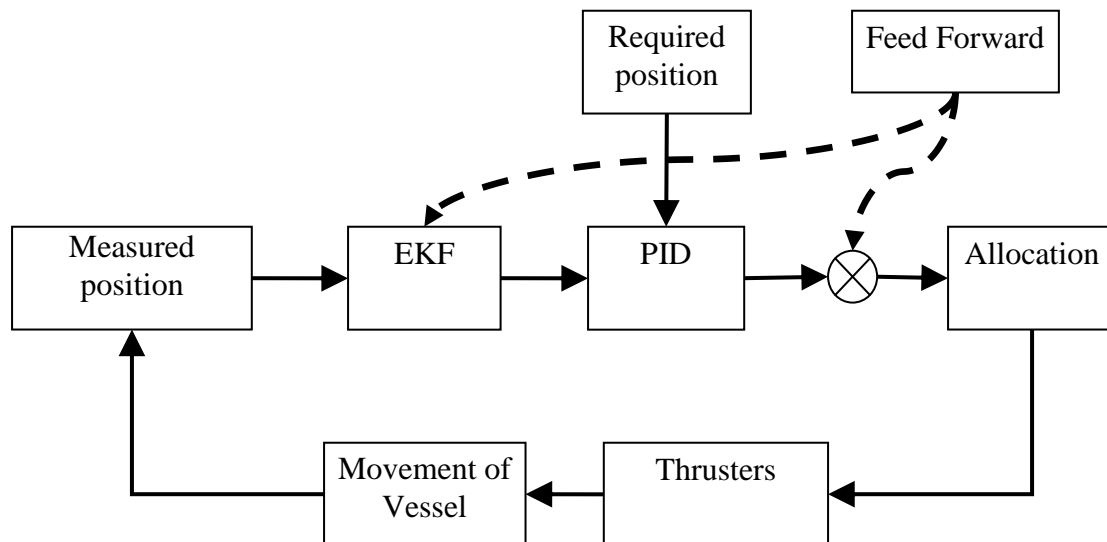

**Figure 6: DP control loop with integrated wave feed forward**

As the control loop is a representation of commercial DP controller, a couple of remarks are made:

- In Figure 6 for two ship tests, the ‘required position’ is the actual (but on-line low-pass filtered) position of the other ship. This is hence a position which follows from relative positioning sensors. This relative position is also showing wave frequency and low

frequency positions. The signal is filtered so that the DP control only acts on the low frequency motions.

- “Measured position” is in this case the actual measured position of the vessel in global coordinates. It is comparable in principle to a GPS signal. The relative position ‘flows’ in the control loop with the “required position”.
- “Feedforward” is supplying a wave force and moment to be added to the PID controller output, as an additional force, but also in the Kalman filter (EKF). The Kalman filter is a low pass filter which smooths and weights the actual position of the vessel. In the Kalman filter, a mathematical model is used. Every available piece of information is used in the Kalman filter to create better filtering. So when forces are known, they should be included in the Kalman filter. This is so for wind feedforward, and also for wave feedforward. The result should be that the so-called “DP-current” (the container for unknown disturbances) becomes smaller and hopefully better defined, resulting in better filtering.

### SINGLE SHIP DP PERFORMANCE IMPROVEMENT

Initially WFF was tested and the performance improvement recorded for a single vessel in a seaway. The MARIN test facility allowed tests to be performed in exactly the same wave trains. This enabled our team to perform a very objective comparison for the performance with wave feedforward enabled and disabled.

After having established what the correct DP settings should be for a ship of this size, several tests are performed in a large variety of sea states. Sea states of interest to the project were sea state 3 and sea state 4. Figure 7 shows the performance in the target wave (wave height  $H_s=2.5\text{m}$ ; peak period  $T_p=8.8$  seconds and bow quartering waves ( $150^\circ$ )). A significant improvement is demonstrated.

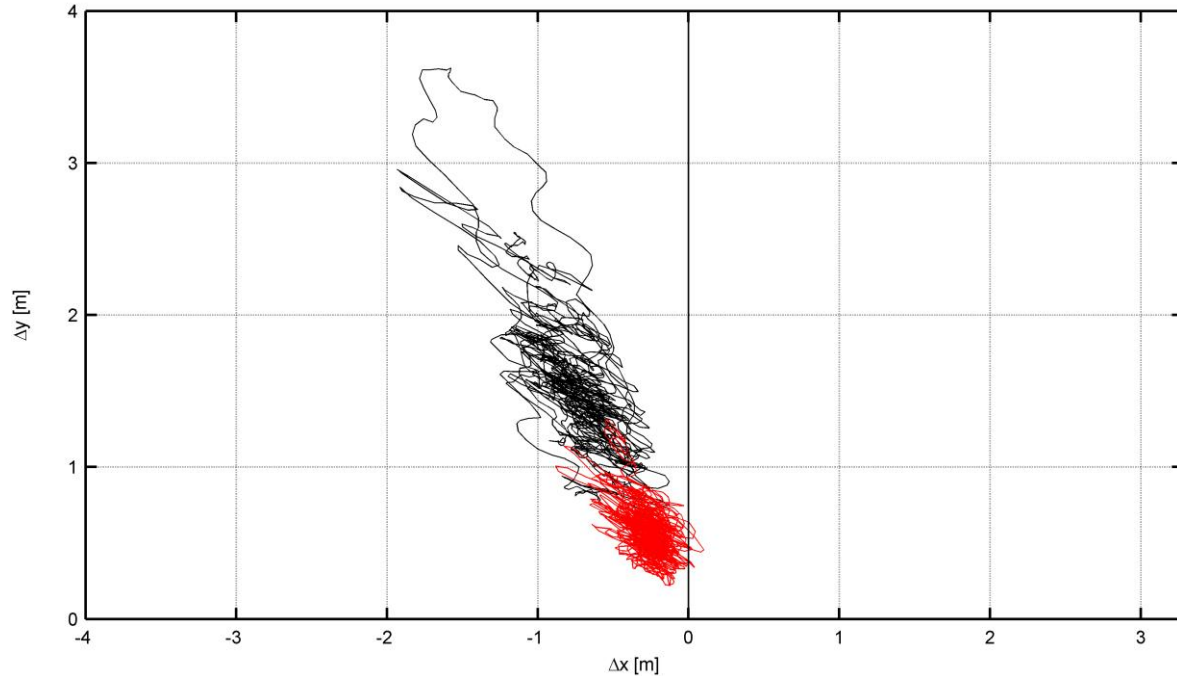

**Figure 7: Footprint of trajectory of the centre of gravity, in surge and sway, of the Mighty Servant 3 in Sea State 4, bow quartering waves; WFF disabled (black line) and WFF enabled (red line)**

A similar performance improvement is demonstrated in waves coming from other directions as well. This is shown in Figure 8

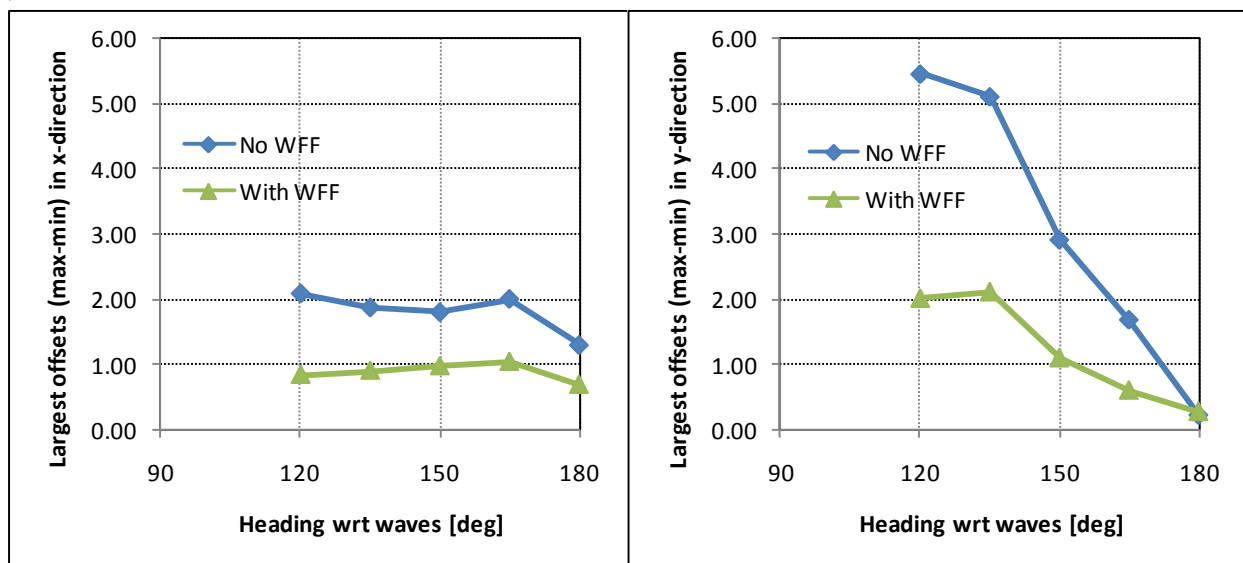

**Figure 8: Improvement in watch circle (shown in surge x, and sway y) in sea state 4, for various wave directions, zero speed**

**TWO SHIP DP PERFORMANCE IMPROVEMENT**

When two ships are taken and relative DP is performed, a similar test approach is carried out: the performance with and without wave feedforward active is quantified in exactly the same wave trains. Figure 9 shows the arrangement in the model basin.



**Figure 9: Photograph showing the two vessels in side by side arrangement, where Mighty Servant 3 (the left vessel) is equipped with wave height sensors to measure the wave feedforward force.**

Figure 10 makes this comparison. It is observed that for a single ship, the watch circle is consistently improved in all environmental conditions, however when a single ship is attempting to maintain its position relative to a second vessel in a seaway, performance is only improved at some headings.

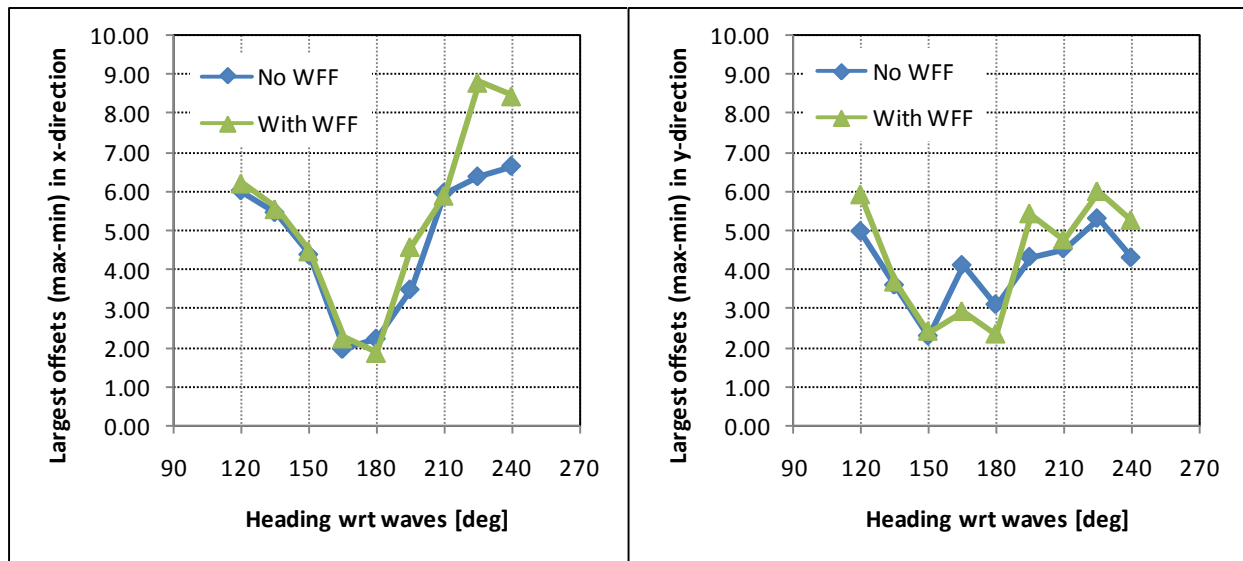

**Figure 10: Comparison of maximum swept path for two ships in relative DP with and without wave feedforward**

Our hypothesis to explain this is that although the knowledge of the wave forces enables the active DP vessel to counteract wave forces and hence improve performance, the second vessel (which does not have a full DP capability or wave feedforward enabled) moves as a consequence of the waves as well. If this movement of the second vessel correlates to the wave induced movements of the MS3, it would be better, momentarily for the DP vessel to move with the wave drift rather than to counteract them.

Several solutions suggest themselves to address the “tracking issue” including the development of a two body Kalman Filter. For this, the motions of the following vessel (in this case the Mighty Servant 3) should be used to predict the motions at the next time step of the second vessel. This would be an interesting next step in the technology progress.

### **CONCLUSIONS**

The application of Pinkster’s method of predicting second order wave drift forces has been successfully applied, in tank tests, to improve the position keeping performance of vessels at zero knots and low ahead speeds. The addition of wave height sensors around a hull, and a simple calculation allowed a COTs-like DP controller to consistently halve the watch circle of a single active vessel in SS3 and SS4. At some headings this improvement was also seen in the relative positioning, two ship, operational scenario of interest in seabasing. However two ship position keeping performance is also greatly affected by the “tracking issue”, so further work in this area is required.

Due to schedule and funding constraints the STLVAST project will not pursue 2-body wave feedforward further but will focus on developing technologies for position keeping of two large vessels, on or near fenders at zero knots and ahead speeds in SS3.

### **Acknowledgement**

Oceaneering would like to thank Geoff Main our ONR STLVAST Program Officer, and also Dockwise for providing vessel information.

### **References**

- [1] Hughes, G, R. Harris and F.H.H.A. Quadvlieg; A Tighter Watch Circle at Higher Speeds; Dynamic Positioning Conference, Houston, 2008
- [2] Pinkster, J.A.; Low Frequency second order wave exciting forces on floating structures; Ph.D. Thesis, 1980
- [3] Aalbers A.B. and U. Nienhuis; Wave Direction FeedForward on Basis of Relative Motion Measurements to Improve Dynamic Positioning. Offshore Technology Conference, No 5445, Houston 1987
- [4] Aalbers, A.B., R.F. Tap and J.A. Pinkster; An Application of Dynamic Positioning Control using Wave feedforward. Int. Journal of Robust and Nonlinear Control, Vol. 11, pp 1207-1237, 2001
- [5] Aalberts, A.B., O.J. Waals, F. Tap and N.J. Davison; Wave feedforward DP and the effect on shuttle tanker operation. Dynamic Positioning conference, September 2004.