



## **DYNAMIC POSITIONING CONFERENCE**

**October 13-14, 2009**

**Design**

---

### **Active Training**

**Tron Resnes**

*Rolls-Royce Marine, Norway*

**Ola Nilsson**

*Citec Information AB Sweden*

---

## Table of Contents

Table of Contents.....	1
1. Introduction.....	2
2. Active Training – The psychology behind.....	3
2.1. Facilities.....	3
2.2. Use of pictures and animations.....	3
2.3. Use of quiz for repetition and practice.....	4
2.4. Use of interactive self-study material.....	4
3. Training Facilities.....	4
4. Training Tool.....	7
4.1. Supported use cases.....	7
4.2. Target groups.....	7
4.3. Overview.....	7
4.4. For the trainer.....	8
4.5. For the training material owner.....	12
4.6. For the learner.....	12
5. References.....	14

*What is Active Training? What makes this something different from the common training activities and courses held around the globe?*

*Active Training defined:*

*“When the training is active, you listen, you ask, you demonstrate. After the course is completed you’re able to teach the course to others”. (Resnes, Nilsson – 2009)*

## 1. Introduction

Rolls-Royce Marine is a world leader within marine solutions, providing products, service and expertise to 30,000 commercial and naval vessels in the offshore, merchant, naval and submarine markets. Rolls-Royce Marine Control Aalesund designs and manufactures world class Dynamic Positioning systems and will by 2011 have approximately have 150 Icon™ DP systems installed on various types of vessels.

Citec Information is one of the largest providers of technical communication services in Scandinavia with more than 500 employees.

Product training has become more important for Rolls-Royce Marine over the last years, due to increasing product complexity and a growing offshore market.

Even though training has been delivered for years, Rolls-Royce Marine in Aalesund seeks new ways to make the learning and training process more effective both for the trainer and learner.

Our focus is to make the learners more active during training. One of the ways of achieving this is to use a lot of pictures, animations and interactivity. To be able to understand a concept, you have to remember it, and to remember it you often have to put it into practice and repeat. Therefore the learners are using DP simulators for practical exercises, but also interactive quizzes are woven into the theoretical parts of the courses.

*When learning has occurred, it implies that a permanent change in a person’s behavioral performance. (Gross, 2005)*

Citec Information has together with Rolls-Royce Marine developed the software Nemo™ to support enhanced classroom training, as described above. In addition, the course material is provided digitally to each learner for repetitive self-studies.

In Rolls-Royce Marine’s concept, training material is delivered to the learners as:

- Digital presentations
- Classroom training
- Simulator training
- Optional self-study material
- Reference Information

*The key to effective training, however, is how the learning activities are designed so that the participants acquire knowledge and skill, rather than merely receive them. (Silberman, 2006).*

This paper presents this new training concept, including facilities and software support, used at the Rolls-Royce Marine training facilities in Aalesund, Norway.

## 2. Active Training – The psychology behind

The main focus in Active Training is how the learning and hence the training takes place. That is why the focus has been on facilities and how the learner perceive the training material.

We believe that the tool can improve and enhance our DP training, as well as any classroom training at all.

The key areas for our Active Training have been:

- Facilities – including the desks
- Use of pictures and animations
- Use of quiz for repetition
- Use of interactive self-study material – The export function

### 2.1. Facilities

The idea during renovation was to keep the facilities as bright as possible, with respect to lightning, walls and ceilings.

By designing the desks ourselves we could focus on how the training occurs. In all training it is of great importance that the course participants do pay attention to the trainer. Classroom based DP training could be performed in various ways, but in the end it will include a mix of presentations on the whiteboard, and self-studies at the DP operator station. Doing both at the same time isn't easy.

Our new DP desks were manufactured with this in mind; Doing one activity at the time.

When the trainer wants the attention of the participants up front, he can lower the 3D visualization screens on all desks. The screens can be raised again when it's time for self-studies behind the DP operator station.

### 2.2. Use of pictures and animations

The human has five main senses (sight, hearing, smell, touch and taste). All the senses have different processing capacities. The famous psychologist Albert Mehrabian showed that the way people process information during a presentation is 55% visual, compared to 38% vocal and only 7% through text (<http://www.presentationhelper.co.uk>). People remember more of what they are told if the experience is multi-sensory, rather than just listening to spoken words or reading printed words on a screen. Using pictures and animations makes it easier for the learner to remember – and the person can link the theory learned (e.g. written text) with pictures.

### 2.3. Use of quiz for repetition and practice

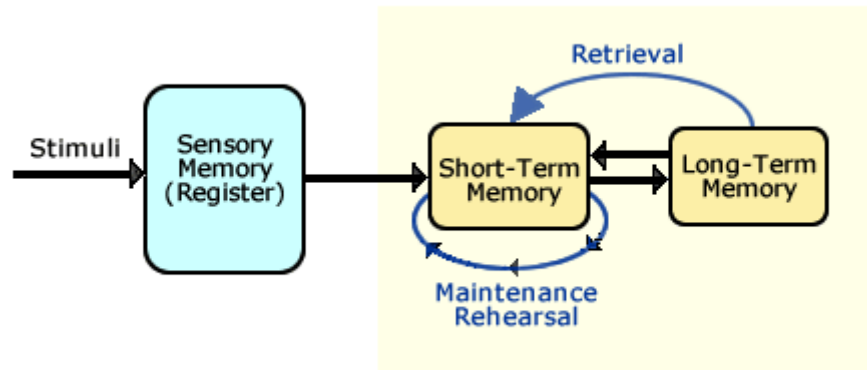

Figure 1 The three basic components of the human memory.

The above picture is showing what is believed to be the three basic components of our memory. (<http://www.hf.faa.gov/>)

The Sensory Memory (also called Register), is the first to be triggered. This is triggered by external stimuli. If the stimuli is “strong enough” it will get our attention. The stimuli in our case would be the Icon DP familiarization course presented to the audience using our training support tool, Nemo™. Attention is very important, especially in training. But getting your learners attention doesn’t imply that training will take place. The inputs must be processed, and if rehearsed, they are stored in the Long Term Memory (LTM). Therefore, the importance of quizzes during the training is vital. Geniuses also have to practice, even Mozart did.

When the information is stored in the LTM you save it for later use. It is believed that the LTM has unlimited capacity. So once the information is stored – you should be able to remember it for a long time and reuse the knowledge when you need it. And if you forget – you actually haven’t forgotten it – you’ve just failed to retrieve it.

### 2.4. Use of interactive self-study material

Retraining is an important factor. To be able to retrieve the information over the months and years ahead you must retrain. To make this more interesting and effective, all our course participants receive an exact copy of the training presentations on a memory stick, including all the slides and reference information with the interactivity and quizzes intact.

This gives the course participants the option of repetition, practice and retraining. They can repeat at their own pace at a location which suits their needs.

The export function has an environmental aspect as well: No need for paper.

## 3. Training Facilities

In general the new Rolls-Royce Marine facilities in Aalesund are designed with respect to lighting, environment and comfort – all to enhance the learning efficiency.

The facilities consist of a classroom with:

- 6 specially made desks with integrated Icon DP simulators with retractable 24" LCDs for 3D visualizations. Each desk has place for two learners.
- 1 specially made trainer's desk with integrated controls for managing the learners simulator stations
- Interactive whiteboard



*Figure 2 Classroom at the Rolls-Royce Marine training facility in Aalesund.*



Figure 3 Classroom at the Rolls-Royce Marine training facility in Aalesund.



Figure 4 Classroom with 3D visualization screens retracted.

The Icon DP simulator stations are capable of simulating realistic environment with 1-channel 3D visualization. All of them can apply as simulator class C according to DNV Standard for Certification No. 2.14 Maritime Simulator Systems.

From the trainer desk it is possible to monitor each of the simulator stations, and create scenarios. It is possible to change weather conditions and recreate failure modes that can occur during DP operations.

## 4. Training Tool

To enhance the training experience and the learning efficiency, the software Nemo™ has been created by Citec Information in close cooperation with Rolls-Royce Marine.

### 4.1. Supported use cases

Nemo™ has been developed to support the following use cases:

- Teaching preparations
- Classroom teaching
- Self studies

### 4.2. Target groups

The identified target groups for Nemo™ are:

- **Trainers**

The trainers are the people that regularly deliver the courses for the learners. Their main tasks with Nemo™ are to add local customer/training session specifics to standard courses, and to use this material during training sessions.

- **Training material owner**

The training material owner will most likely be a training manager. This role will be responsible for updating/maintaining the standard training material, and to publish new course material.

- **Learners**

The learners are the course participants. They use Nemo™ for viewing exported versions of attended courses after the course occasion. This version of Nemo™ is only a presentation player. It is not possible to modify the contents of the course.

### 4.3. Overview

The basic idea with Nemo™ is that all courses within an organization should be treated as standard courses, and therefore they are to be stored and maintained as such centrally in the organization, available for (all) trainers and training material owners.

Nemo™ aims to combine training and technical information tighter together. This is done by using the technical information dynamically in the training courses, as detailed information, or

“Learn More”. This information is managed by e.g. the documentation team or technical publication department. It is stored and maintained centrally at **one** place the organization. However, this feature is optional, and is not required to implement.

Figure 5 shows an overview of how and where the material is stored, depending on who is performing the changes.

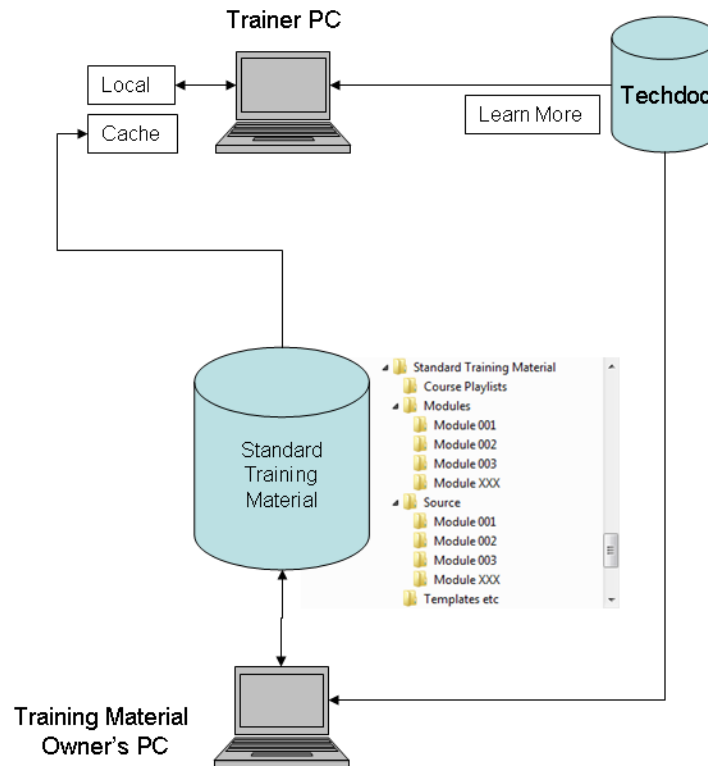

Figure 5 Storage of information used in Nemo™.

Nemo™ has been designed and developed with training in focus, but there are also other applications where it can be used with great advantage, e.g. in sales and marketing, but also in R&D.

#### 4.4. For the trainer

The most frequent user of Nemo™ is the trainer, who uses it in both preparations and during classroom training repeatedly.

##### 4.4.1. Preparations

When a trainer is preparing for a specific course (that has to be prepared in advance), the basic process is:

1. Open a published standard course.
2. Make customer/course occasion specific changes or additions to the material, and save. These additions/changes will be saved locally, and not be a part of the standard course.

3. Export the customized course, either digitally on e.g. a memory stick or on paper.

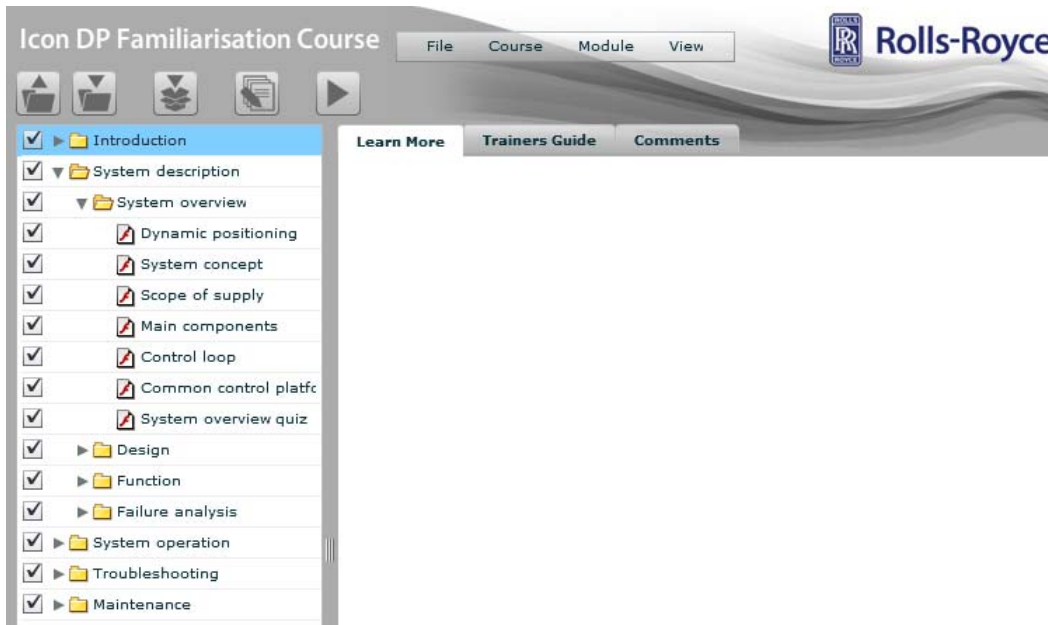

Figure 6 Screenshot from the course editor window in Nemo™.

### Make customer/course occasion specific changes or additions

The customer, or course, specific changes that can be done in Nemo™ are:

- Edit courses, i.e. changing the course structure and name, but also adding and deleting modules from a course.
- Print courses (or parts of courses).
- Export courses (or parts of courses) for distribution to learners.
- Edit Nemo™ settings.
- Edit course modules:
  - Add/remove media objects from a module. A media object can be flash files (.swf) or images and text blocks, depending on the type of module.
  - Save changes to the module locally. Standard modules are not affected, when changed from the module editor. Instead a local copy of the standard module is created.
  - Change the size and location of media objects.
  - Edit “Learn More” information connected to the module.
  - Edit module properties, i.e. what template the module is using, module title and which slides of the module that should be output on print.

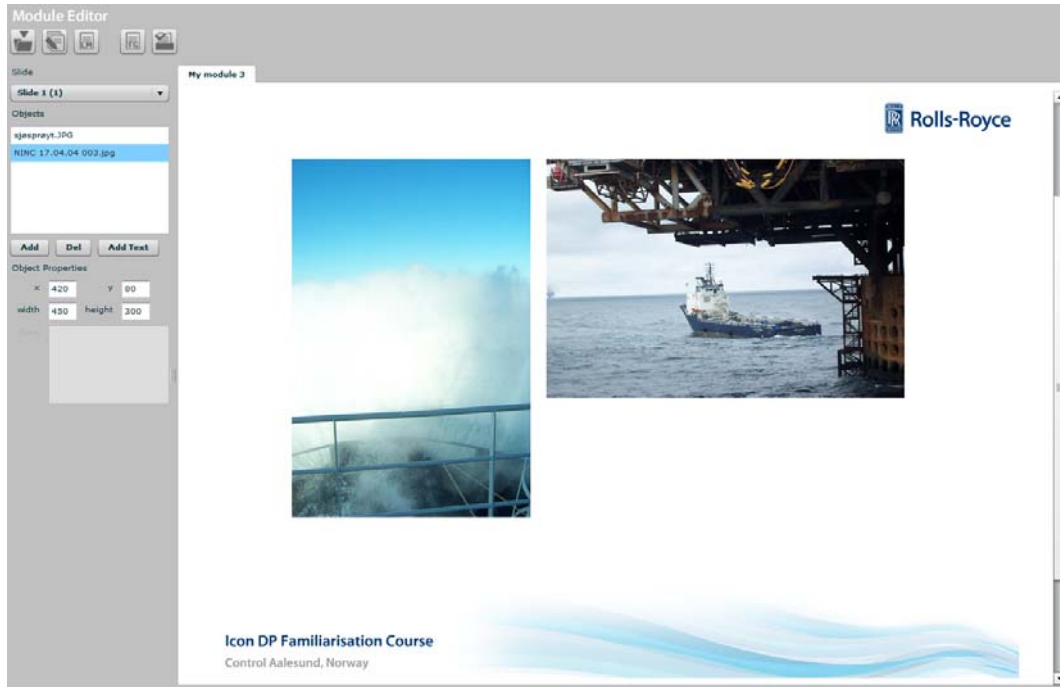

Figure 7 Screenshot from the module editor window in Nemo™.

For self assessment, it is recommended to end each course block with an interactive quiz, which the learner could take repeatedly after the course. The quizzes can also be used as common exercises during classroom training. This kind of exercise often starts discussions in the class, and hence the learners are more active, which is what we want to achieve.

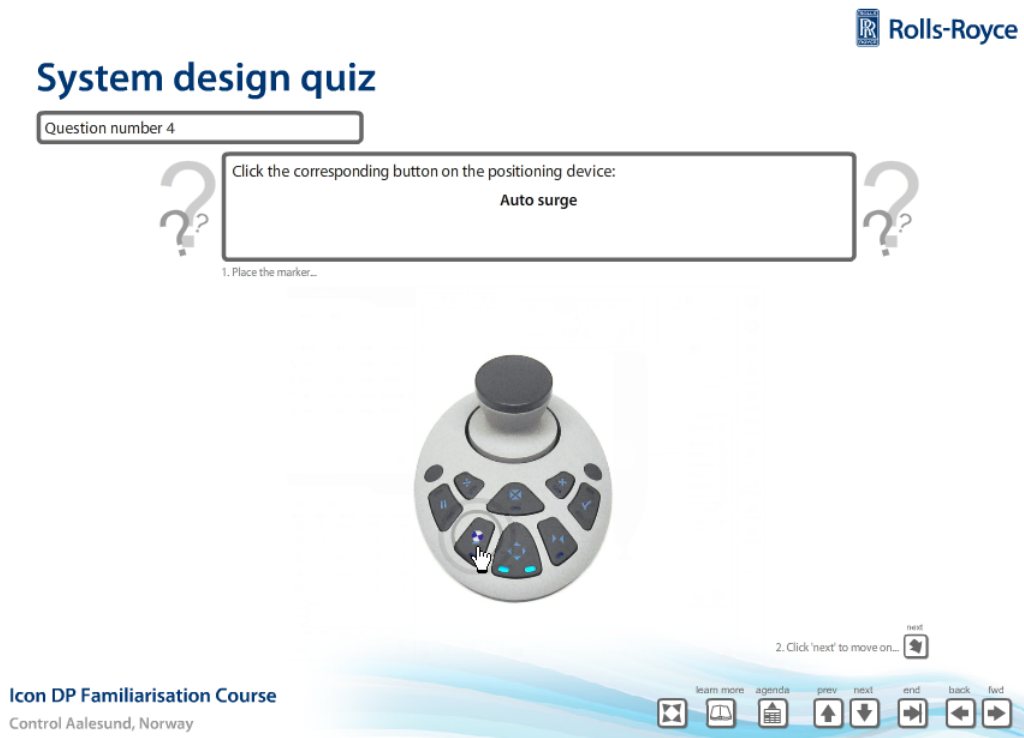

Figure 8 Screenshot from a quiz in Nemo™.

## Export the customized course

Nemo™ supports export of the customized course files, for later self-studies by the learners themselves. The course presentation will be displayed in a standalone course presentation player.

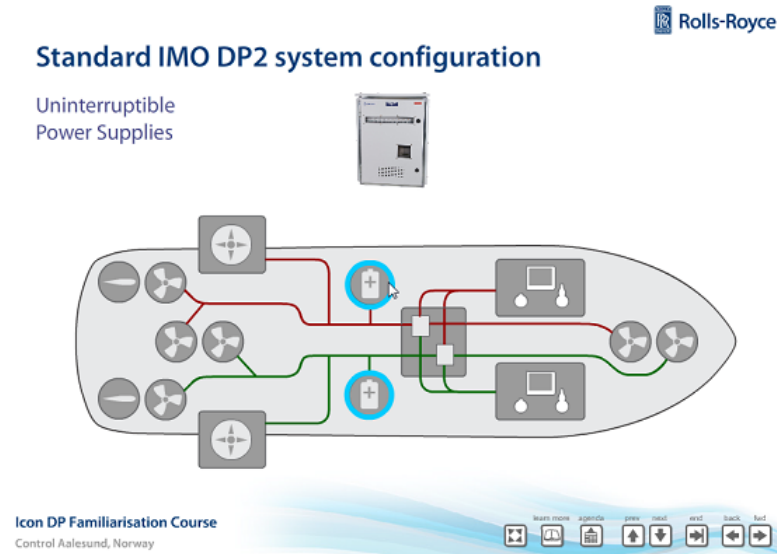

Figure 9 Screenshot from the course presentation player in Nemo™.

### 4.4.2. Classroom training

In the course presentation player window the course presentation media is presented. This window is usually output on a projector during the course session.

The course presentation player is also the only available user interface in the viewer version of Nemo™.

The course presentation is controlled from the course presentation player in terms of:

- Toggle show/hide of course structure. (Only modules ticked of in the course structure in the Course editor are shown).
- Toggle show/hide of Learn More information for the selected module in the player.
- Go forward/back between slides/frames in the presentation.
- Go to the next/previous module in the presentation.
- Go to the last frame of the selected slide.
- Toggle full-screen.
- Present the material.

The trainers guide tab in the course editor window is displayed for the trainer only, to assist during the classroom training. It contains information as how long the slide are calculated to be shown, what to say to the slide, what is most important to tell (if short on time) and so on.

The screenshot shows a software interface for a trainer's guide. At the top, there are three tabs: 'Learn More', 'Trainers Guide' (which is active), and 'Comments'. Below the tabs, the main content area is titled 'Operational Modes' with a 'time: 4 min.' indicator. The 'Operational modes' section includes a sub-section for 'Joystick' with instructions: 'To use the independent joystick control must be activated. Activation of joystick control: 1. Set the manoeuvring mode switch to Joystick control. 2. Press the System activate button on the backup joystick box.' To the right of this text is a 3D model of a Rolls-Royce engine with the label 'Independent joystick'. Below the text is a small image of a control panel with a joystick and buttons. The 'Story' section is marked 'N/A'. The 'Traps' section is marked 'None'. The 'Important' section contains a warning: 'Even though you have set the manoeuvring mode switch to joystick control, you have control over the thrusters on the manual levers. The backup joystick is not active before you have pressed the activate button. This is important to be aware of! Always know where the commando is and always have a backup plan.' The 'Actions' section lists: '• Show functions using the interactive manoeuvring mode switch: • Standby • Joystick control • DP control'. At the bottom left, there is a small logo for 'Iron DP Panel for the Course'.

Figure 10 Screenshot from the trainers guide pane in Nemo™.

#### 4.5. For the training material owner

The training material owner has full rights to all functions of Nemo™. This means that he can, on top of everything the trainer can do, publish new standard courses, or update existing ones, making them available as standard courses for all trainers within the organization.

#### 4.6. For the learner

Nemo™ is also designed to support export of course presentations for learner self studies. The exported material is, as a suggestion, distributed to the learners on a memory stick.

When a learner is starting to self-study the material, the basic procedure is:

1. Insert the memory stick into an USB port on the PC.
2. Double-click the **start.exe** file.  
The installation of a viewer version of Nemo™ will start. If Adobe AIR is not installed on the PC, it will first install this (also included on the USB).
3. When installed, open Nemo™. The presentation will start automatically.

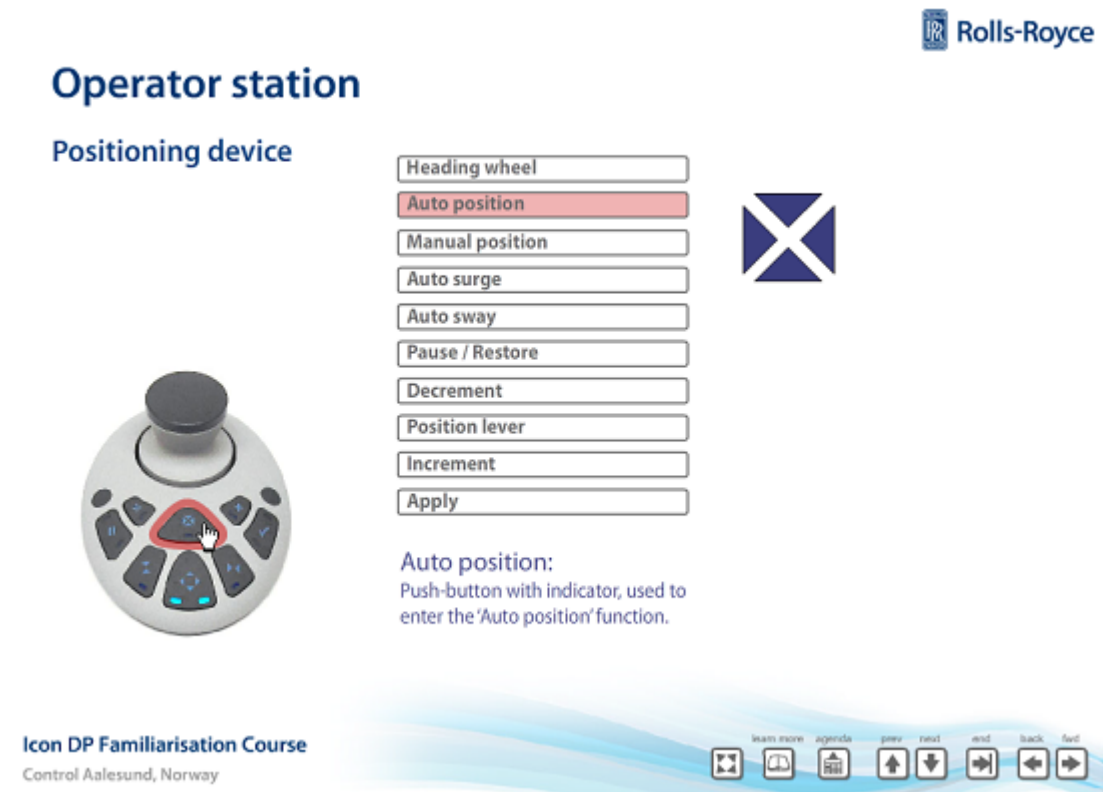

Figure 11 Screenshot from Nemo™ Viewer.

#### 4.6.1. Nemo Technology Overview

Nemo has been developed using the Adobe© Flex® 3.3 Software Development Kit (SDK) which is licensed as open source and is built upon the Flash platform. The Flash/Flex platform offers a wide range of both open source and licensed software for media creation. No other platform for rich media applications is as widespread and mature as the Flash platform. Other technologies, as Microsoft© Silverlight™, require more programming when creating media than Flash, or a larger investment in application development.

Most users already have a Flash-player installed on their computers, and therefore no other applications should be needed to run Nemo™ or play its media. So why do you have to install the AIR player before running Nemo™? The simple answer is that the Flash-player has restricted access to the computers local storage and Nemo™ needs a way to store files. The AIR extension to the Flex® 3.3 SDK solves this problem and admits access to the local file system.

#### 4.6.2. Future Possibilities

The requirement of an AIR-player could be excluded in future releases of Nemo™. This is solved by using a web server with a database for file and metadata storage. This also gives advantages such as the possibility to version control files and metadata, search function for courses and modules and easy implementation of user and access control.

## 5. References

Gross, R. (2005), *Psychology the Science of Mind and Behavior, 5th edition.*

Silberman, M. (2006), *Active Training*

<http://www.hf.faa.gov> (April 2009)

<http://www.presentationhelper.co.uk> (September 2009)