



DYNAMIC POSITIONING CONFERENCE
October 7 - 8, 2008

Risk, FMEA and Reliability

**Machinery Systems for DP Vessels with
Increased Efficiency and Reliability**

Terje Nordtun

Wärtsilä Norway AS (Stord, Norway)

Abstract

Offshore support vessels (OSV) have increasingly developed into larger and more powerful ships responding to new operational requirements and the need for more flexible designs. For DP classed vessel it is crucial to have propulsion machinery solutions with high degree of redundancy and reliability. Also, efficient utilization of the power plant in the different operational modes is becoming more important with increasing fuel prices and environmental concern. This paper will address Wärtsilä's diesel electric machinery concepts, with special emphasis on advantages for DP classed vessels. The Wartsila Low Loss Concept (LLC) will be presented. This diesel electric system has a number of advantages compared with conventional concepts. The main characteristics of the LLC system is reduced electrical losses meaning better fuel efficiency. In addition, the system gives substantial weight and space saving for the installation. Finally the architecture of the switch boards and power distribution system gives less single failure consequences, meaning higher safety and reduced risk for the DP vessel operation

Diesel Electric Propulsion systems

Diesel electric (DE) propulsion has over the year's gained more market share onboard offshore support vessels. Both the technology development in diesel electric systems and the increasing demand for safety and operational flexibility have supported this development. Traditionally, diesel mechanic (DM) propulsion systems have been considered as more fuel efficient, as the electric losses in DE systems may be substantial. Consequently an additional fuel penalty of about 10% has been claimed for the DE systems. However, this fuel penalty is not taking into account the complete picture for a DP classed vessel with different operational modes. Here propeller efficiencies and main engine performance needs to be included for the different running conditions to make a complete fuel efficiency comparison between DM and DE systems. From such investigations a DE system may in some cases be a better alternative also with regard to fuel total fuel economy.

General description of DE systems

Typical DE systems for OSV vessels will consist of 4-6 diesel-generators producing all required power for propulsion and other consumers onboard. Total installed power onboard will of course depend on the vessel size and type of operation, but normally it will be between 6 and 10 MW.

Figure 1 shows a typical 8 MW DE system for an OSV. The electrical power produced by the diesel-generators will be distributed throughout the total installation to the different consumers via transformers, switchboards and frequency converters.

The total power system must be monitored and controlled with one or several control systems depending on the level of system integration. Extensive use of power electronics and a modern Power Management Systems (PMS) is essential to control the dynamic electrical network in a DE system. The PMS can either be a stand alone system or it can be integrated in a total Vessel Automation system.

Typically for these vessels the propulsion power requirement in economic transit speed is in the range 3000 – 4000 kW. During DP operation the power requirement will be very weather dependant, in the order 600 – 1500 kW in calm weather increasing to 3000 – 5000 kW in rough weather.

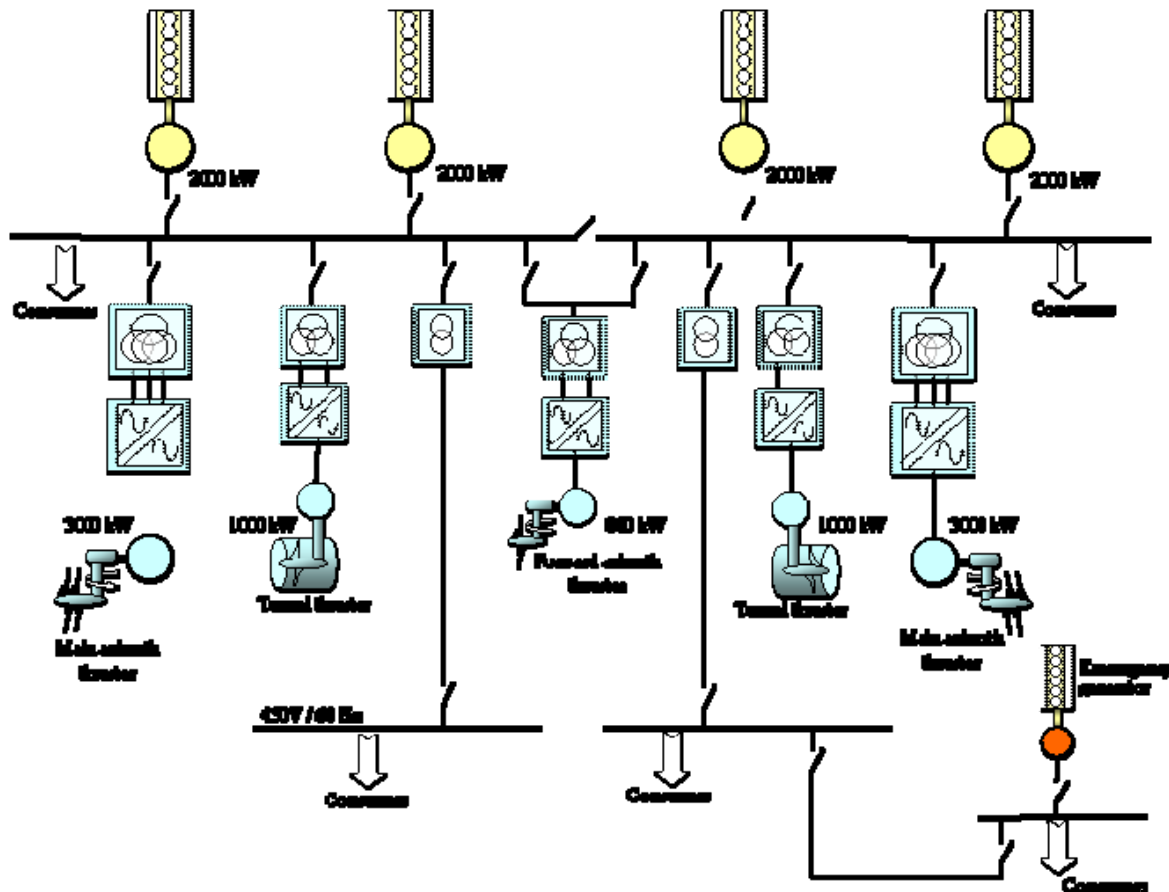

Figure 1. Typical single line diagram for OSV

DP requirements

Requirements for systems onboard DP vessels are regulated by the IMO Guidelines for Vessels with Dynamic Positioning Systems. Here the DP systems are grouped in 3 different equipment classes according to the level of redundancy. For equipment class 2 & 3 the positioning keeping system must be redundant, meaning that a single failure in components or systems must not lead to a loss of vessel position.

For class 2 and 3, IMO also requires an online consequence analysis system during DP operation. This function must continually perform an analysis of the vessel's ability to maintain its position and heading after a predefined single worst case failure during operation. Possible consequences are based on the actual weather condition, enable thrusters and power plant status. Typically worst case failures are:

- Failure in the most critical thruster
- Failure in one thruster group
- Failure in one switchboard section

The consequence analysis will warn the operator if the weather and systems conditions are such that the single worst case failure will cause position drift-off. Pending on the criticality of the actual operation, if such a warning occurs, the DP operation may need to be aborted.

From the above it is obvious that one measure to increase a vessel's DP capability is to seek for arrangements in the system design that will reduce the worst single failure consequence.

Wartsila Low Loss Concept (LLC)

The Wärtsilä LLC is a specially designed and patented Diesel Electric system **primarily** developed for Offshore Support Vessels. Main features of the concept are reduced electric losses, increased reliability and less space requirement.

The basic principle of the LLC is shown in Fig. 2. In traditional systems the frequency converters are protected from the harmonic distortion in the net by having transformers at the power intake for each individual converter. In a LLC system these transformers are removed and a LLC transformer is installed and connecting the switchboards. Power for each frequency converter is duplicated, and supplied from individual switchboard sections. The LLC transformer performs phase vector difference enabling 12-pulse supply to the frequency converters. This special arrangement will reduce the total harmonic voltage distortion (THD) in the system, i.e. propulsion transformers can be omitted. Also, in normal operation almost no current is passing through the LLC transformer, meaning that transformer losses present in conventional DE systems are to a large extent eliminated.

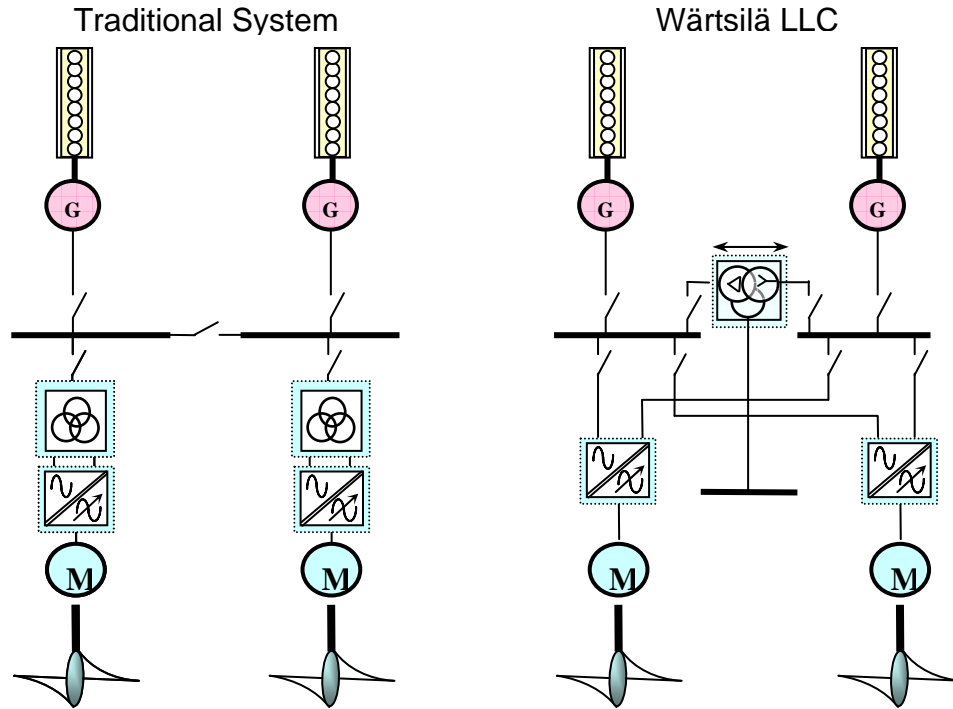

Fig. 2 LLC basic principle

A typical LLC Low Voltage system for and OSV is shown in Fig 3. It is based upon a symmetrical design for the port and starboard side of the power generation, power distribution and propulsion supply systems.

The power generation system consists of four (4) diesel engines as prime movers of four (4) low voltage generators. These generators are supplying power symmetrically to a switchboard system of four (4) main 690V switchboards. These main switchboards are connected via two (2) LLC transformers.

On the port side generator G1 is connected to switchboard A1. Generator G2 is connected to switchboard A2. On the starboard side generator G3 is connected to switchboard B1. Generator G4 is connected to switchboard B2. Bus-tie breaker connects switchboards A2 and B1. Bus-link connection connects switchboards A1 and B2.

Frequency converters and the LLC transformers can be situated in the switchboard rooms.

This will simplify installation and commissioning, and make operation and maintenance easier.

No transformers or converters need to be located in the thruster rooms, i.e. more space will be available for other purposes

The advantages of the LLC can be summarized as follows:

- The LLC gives increased robustness in DP mode by **providing** more available propulsion and thruster power at the occurrence of a single failure.
- The main switchboard is segregated into four sections with dual bus connection through bus-link and bus-tie breakers. This increases operational flexibility and availability.
- The LLC gives lower fuel consumption and reduction of environmental pollution by reduction of the electric losses in the system
- Personnel safety is significantly increased due to reduced short circuit levels on the 690V switchboard
- Weight and space requirements for the electric system components are significantly reduced.
- THD level on the 690V power distribution is below 5%

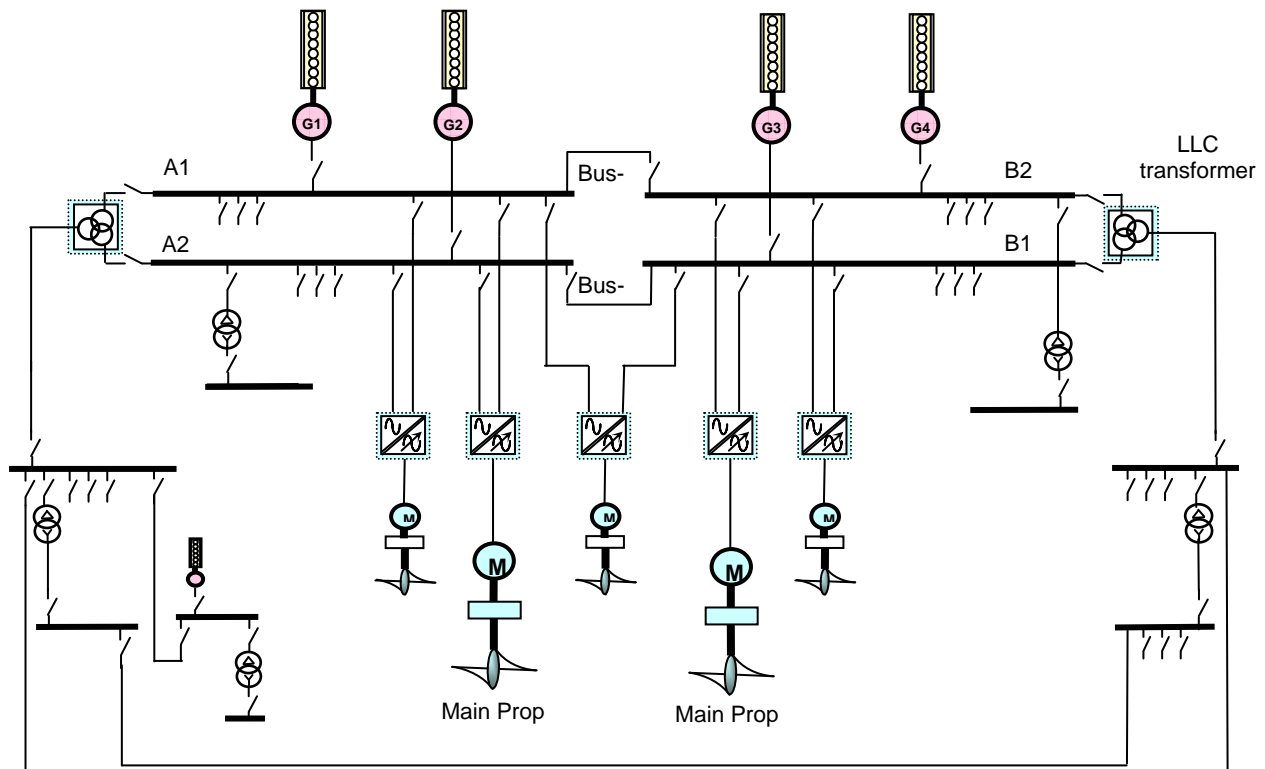

Fig.3. Typical DE system for OSV based on Low Loss Concept

Failure modes and consequences on DP operation

In the table below, the LLC failure modes and consequences have been summarized and compared with a traditional DE system. The LLC system will result in or provide less operational consequences with regard to failures in transformers, in switchboards and in bus tie breaker or link.

Failure	DP Operational Consequences	
	LLC	Traditional System
Failure in transformer	<ul style="list-style-type: none"> • All propellers will be in operation • Low level of THD will be maintained • Power generation capacity is not reduced. • No influence on vessel's operational capacity 	<ul style="list-style-type: none"> • Main propeller on one side will be out of operation • Power generation capacity is not reduced • Major influence on vessel's operational capacity
Failure of main converter for main propulsion	<ul style="list-style-type: none"> • Main propeller on one side will be out of operation • Power generation capacity is not reduced 	<ul style="list-style-type: none"> • Main propeller on one side will be out of operation • Power generation capacity is not reduced
Failure of central switchboard, port side (A2)	<ul style="list-style-type: none"> • All propellers will be in operation • Reduced by 25% of total power capacity • Except for "high power modes" the failure will not influence the vessel's operation • Power production is reduced by 25 % 	<ul style="list-style-type: none"> • 50% or the propellers will be in operation • Reduced by 50% of total power capacity • Major influence on vessel's operational capacity • Power production is reduced by 50 %
Failure of peripheral switchboard port side (A1)	<ul style="list-style-type: none"> • All propellers will be in operation • Reduced by 25% of total power capacity • Except for "high power modes" the failure will not influence the vessel's operation • Power production is reduced by 25 % 	<ul style="list-style-type: none"> • 50% or the propellers will be in operation • Reduced by 50% of total power capacity • Major influence on vessel's operational capacity • Power production is reduced by 50 %
Failure of bus-tie breaker or link	<ul style="list-style-type: none"> • All propellers will be in operation • Capacity is maintained • Power production is maintained • DP2 operation maintained through alternative bus-link 	<ul style="list-style-type: none"> • All propellers will be in operation • Capacity is maintained • Power production is maintained • DP2 operation not possible
Failure in one PMS node (PLC)	<ul style="list-style-type: none"> • No influence on vessel's operational capacity 	<ul style="list-style-type: none"> • No influence on vessel's operational capacity

Example case - LLC on a PSV vessel

The first vessel with Wärtsilä LLC entered service in 2005. Since then about 10 vessels have been delivered, and about 50 vessels are under construction with the LLC.

As an example of a recent Wartsila LLC delivery, the propulsion system onboard M/S Viking Queen will be described more in detail. Viking Queen is a Multipurpose Platform Support Vessel of Vik Sandvik design serving oil rigs, oil platforms and other offshore installations. The vessel has LNG gas/diesel (dual fuel) electric propulsion, is 92,2 meter long and has accommodation for 25 persons. The vessel is built by WestCon shipyard in Norway for Eidesvik Shipping AS. She was delivered in January 2008 and is operating in the North Sea on a long term time charter for StatoilHydro.



M/S Viking Queen

Main machinery and propulsion particulars are as follows (ref Fig 4):

Vessel Design	VS 493 Avant LNG
Vessel Dimension (LxBxD).....	92.2 x 21.00 x 9.60 m
Main diesel-generators.....	4 x Wartsila 6L32DF (4 x 1950 kW)
Main propulsion.....	Pulling type thrusters – 2 x 2300 kW
Tunnel thrusters forw.....	2 x 1200 kW
Azimuth thruster forw.....	880 kW
Integrated Automation and PMS.....	Wartsila
DP System.....	Kongsberg DPC-2
DNV DP Class.....	AUTR (IMO DP Class 2)

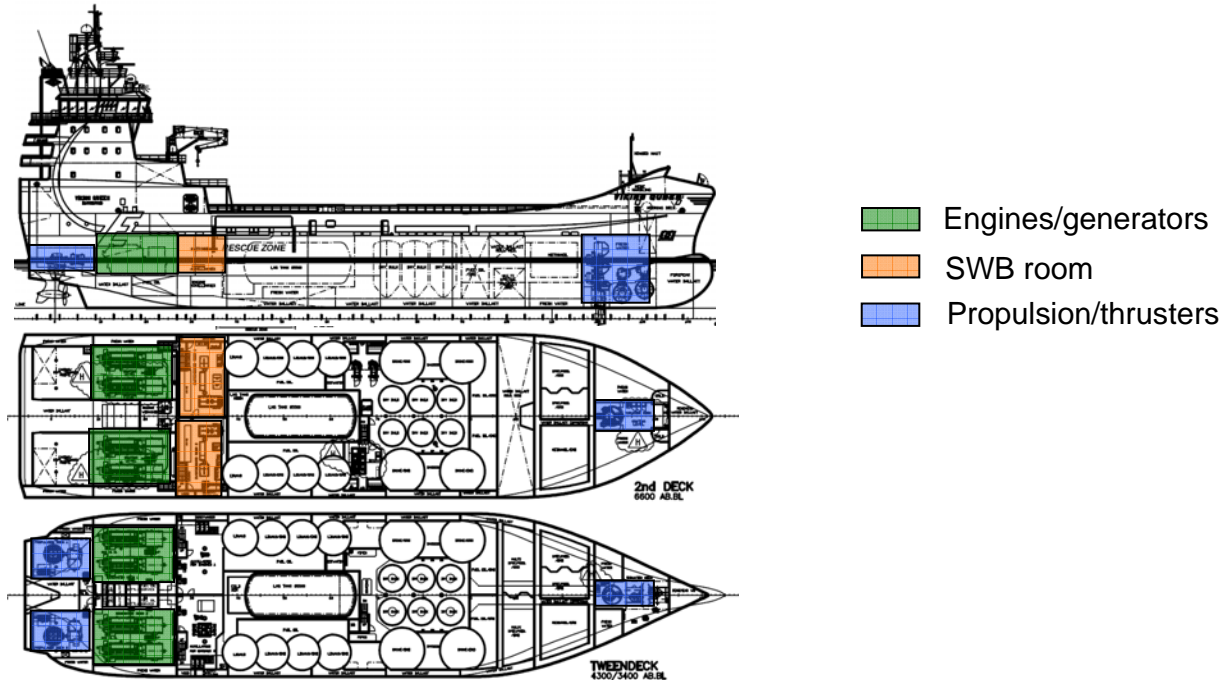

Fig 4. Viking Queen – Machinery and Propulsion arrangement

Arrangement

One of the characteristics with the LLC is less space requirement for the equipment. No transformers or frequency converters need to be installed in the propulsion rooms, and this feature has been fully utilized in the vessel design for Viking Queen. The LLC transformers and propulsion converters are placed in the two switchboard rooms (ref. Fig. 4), making it possible to minimize the size of the propulsion rooms, and thus increasing the available under-deck volume for cargo. This increased volume is naturally of high value for a PSV.

The main 690V switchboard (SWB) is arranged in four physically separated sections with A1/A2 in port SWB room and B1/B2 in starboard SWB room, ref. single line diagram in Fig. 5. The switchboard sections are connected via bus tie / bus link breakers. The SWB rooms also contains the two 1600 kVA LLC transformer units, each of them including a 640 kVA/450 V distribution transformer for other non-propulsion consumers onboard. All thrusters are of fixed pitch design driven by frequency controlled electric motors. The frequency converters are all made by Wartsila. These are 12 **pulse** type based on IGBT transistor technology with PWM and advanced vector control.

All switchboards onboard are made by Wartsila. They are designed to withstand the high short circuit current that may occur when all main generators sets, LLC transformers and 230V transformers are running in parallel.

The electric system is designed in such a way that it will give a selective disconnection of any electrical fault on the main bus bars and main feeders, with protection of the individual electric components. For instance a short-circuit on bus bar A1 will open bus bar breaker towards bus bar A2 as well as bus link towards bus bar B2, before trip of generator breaker.

The 690V main switchboard is designed and constructed for operation with both open bus tie / bus link and with closed bus tie / bus link. Bus bar A1/A2 and B1/B2 will in normal operation be connected via the LLC transformers. For DP2 class operation, the safest set-up will be with bus tie breaker in open position. However, closed operation is also allowed, giving a more efficient utilisation of the diesel generators, with better engine running condition and lower fuel consumption. The switchboards can be controlled and monitored locally or automatically from the IAS/PMS. The PMS is arranged for automatic operation for both open and closed bus tie.

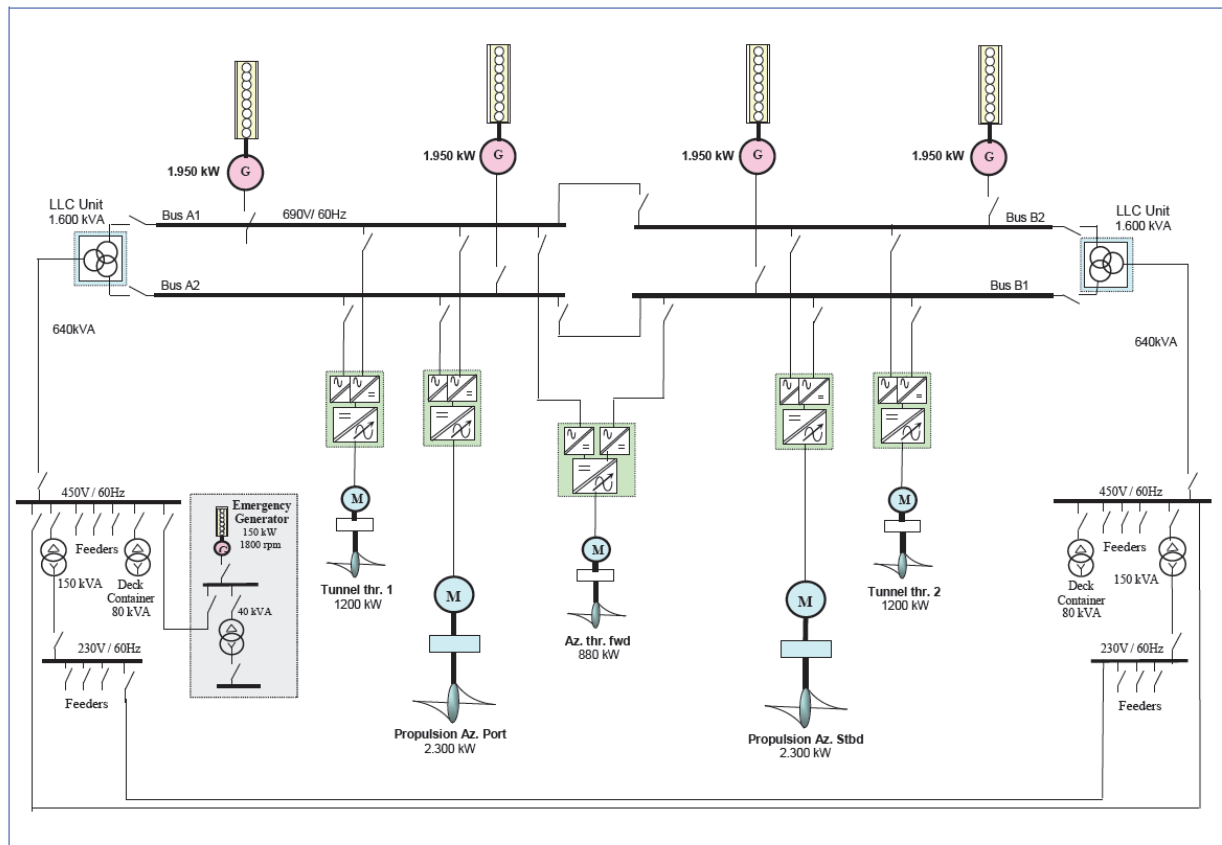

Fig 5. Viking Queen – Single line diagram

Worst Case Single failure Consequences – FMEA test

The FMEA analysis and tests carried out onboard Viking Queen has proven the special features of the LLC. One of the conclusions from the FMEA report is as follows:

“From the design documentation, we can not find any single fault that will stop or disconnect more than 1-one generator set simultaneously. If short circuit in 1-one of the 4-four 690V busbars, or in the LLC transformer occurs, then, the bus-tie breaker will open and prevent generators on other parts of the main switchboard from tripping”

The above conclusion was tested and proven during the FMEA tests. Table 1 summarizes the remaining thruster capacity during loss of individual busbar sections. For all of these busbar failures, the remaining generator capacity will be 5850 kW (3 x 1950 kW) which is 75% of the full installed power.

The total remaining propulsion capacity during loss of busbar A1 or B1 will be 5690 kW, which corresponds to 73% of total installed power. Loss of busbar A2 or B2 will have even less consequences, as 79% (6130 kW) of the full power still will be available for propulsion.

Loss of Busbar	Remaining thruster capacity (%)					Remaining prop. power (kW / %)
	Main PS	Main SB	TT 1	TT 2	Fwd Azim	
A1	50	100	50	100	50	5690 / 73
A2	50	100	50	100	100	6130 / 79
B1	100	50	100	50	50	5690 / 73
B2	100	50	100	50	100	6130 / 79

Table 1. Remaining thruster capacity during loss of one busbar

Full scale measurements of electric Losses

Electric losses in the propulsion system for Viking Queen have been measured in full scale. The principal setup of the measurement is shown in Fig 6. The losses have been measured between the output from the diesel engines and the output from the electric propulsion motors by use of strain gauges. The measurements were carried out on the port distribution side, and in order to eliminate the influence from the utility power (power for hotel and other auxiliary consumers) all these consumers were supplied and isolated to the starboard side by running with open switchboard connections. Thus during the tests the port diesel-generators G1 and G2 were only supplying power to the port main propulsion frequency converter and a minor amount of power (3-10 kW) to the port thruster utility system (lubrication and steering). This thruster utility power has been excluded from the efficiency calculation in order to get the most correct results for the pure electric losses.

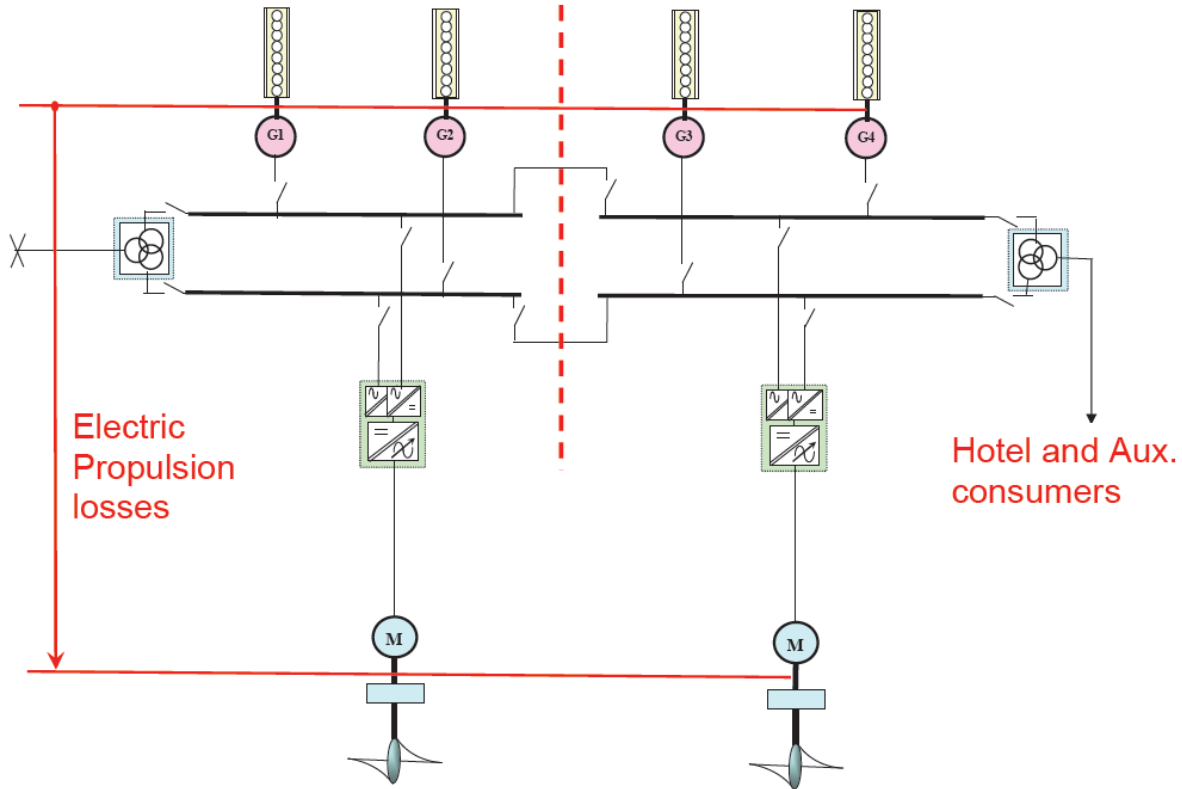

Fig 6. – LLC - Full Scale measurements of electric propulsion losses

A summary of the results from the full scale measurements are shown in the table 2 below. As can be seen the measured electric losses are in the range of 4 – 7 % which is **remarkably** low. Also the losses are higher in the tests where only one generator (G1) takes the whole load on port switchboard. This is as expected as in this case some of the power to the propulsion converter needs to pass through the LLC transformer giving some additional losses. When the electric load is equally distributed between G1 and G2, practically no power is passing via the LLC transformer, which explains the lower losses measured during these tests.

	Test 1		Test 2		Test 3		Test 4		Test 5	
	Port	Stb.	Port	Stb.	Port	Stb.	Port	Stb.	Port	Stb.
Generators running	G1	G3	G1 G2	G3	G1	G3 G4	G1 G2	G3 G4	G1 G2	G3 G4
Diesel Power (kW)	1261	1526	1253	1531	1692	2021	1676	2078	2253	2588
Propulsion Power (kW)	1176	1139	1198	1155	1578	1555	1603	1592	2129	2121
Electric losses	6.74%		4.39%		6.74%		4.36%		5.50%	

Table 2. LLC - Results from Full scale measurement of electric propulsion losses

Conclusion

In this paper the special features of the Wärtsilä Low Loss Concept (LLC) for diesel electric have been described. For DP classed vessels it gives higher overall reliability in the electric power distribution, with less single failure consequences compared with conventional systems. Thus DP vessels fitted with the LLC will be able to increase the DP capability. The LLC is designed to reduce the electric losses in diesel electric propulsion systems, and this feature has been confirmed by full scale measurements. Total electric losses of about 5% have been measured, which is significantly lower than common figures for conventional diesel electric systems.