



Sensors II

Using Doppler Logs for Safer DP Drilling

Dr. Richard Stephens

Allan Meahan, John Flint

Alstom Power Conversion



APC Power Conversion

Using Doppler logs for safer
DP in drilling

Richard Stephens

Allan Meahan, John Flint

Customised Technology for Customer Success

- DP and PMEs
- Doppler log (speed log)
- Achieving independence
- Simulation results
- Full scale trial data



Customised Technology for Customer Success

Summary

APC

- The problem
 - lack of independent PME's
- Loss of PME's leads to:
 - down time
 - delay
 - incidents
- The solution
 - use Doppler log as back up

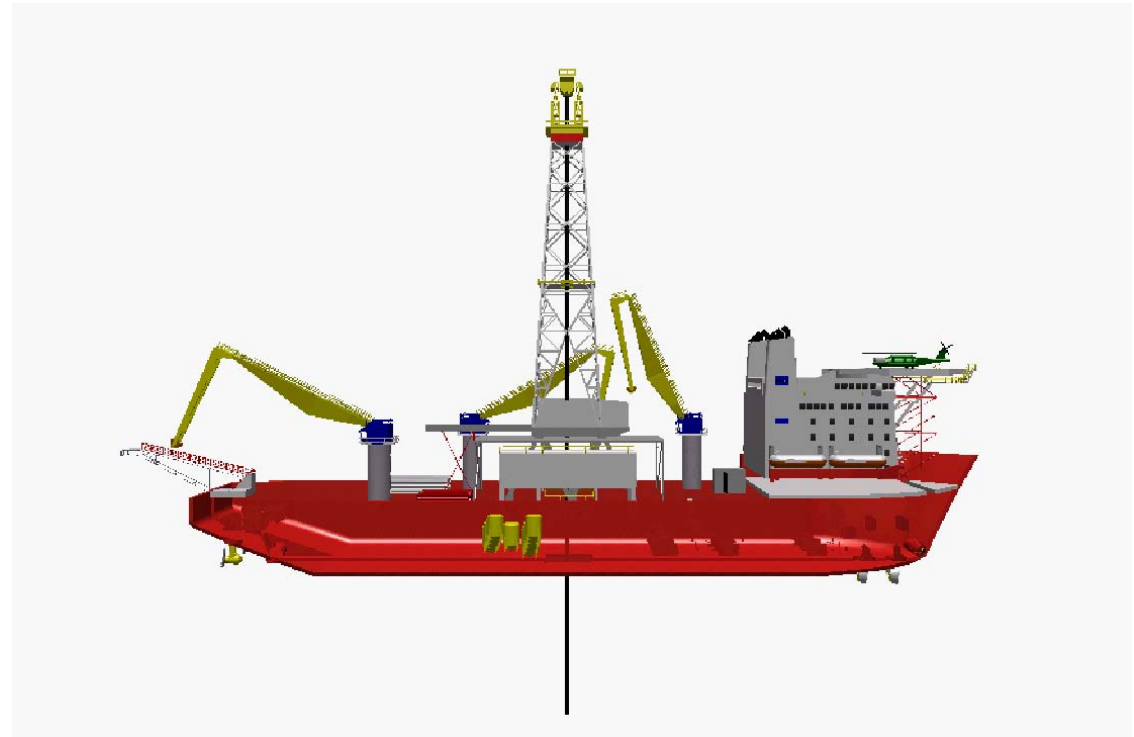

Customised Technology for Customer Success

Dynamic positioning

APC

- Maintains vessel in fixed position relative to a fixed reference point
- Fixed heading
- Position controlled by PME
- Heading controlled by gyro-compass
- Position and heading can be changed whilst in DP Mode

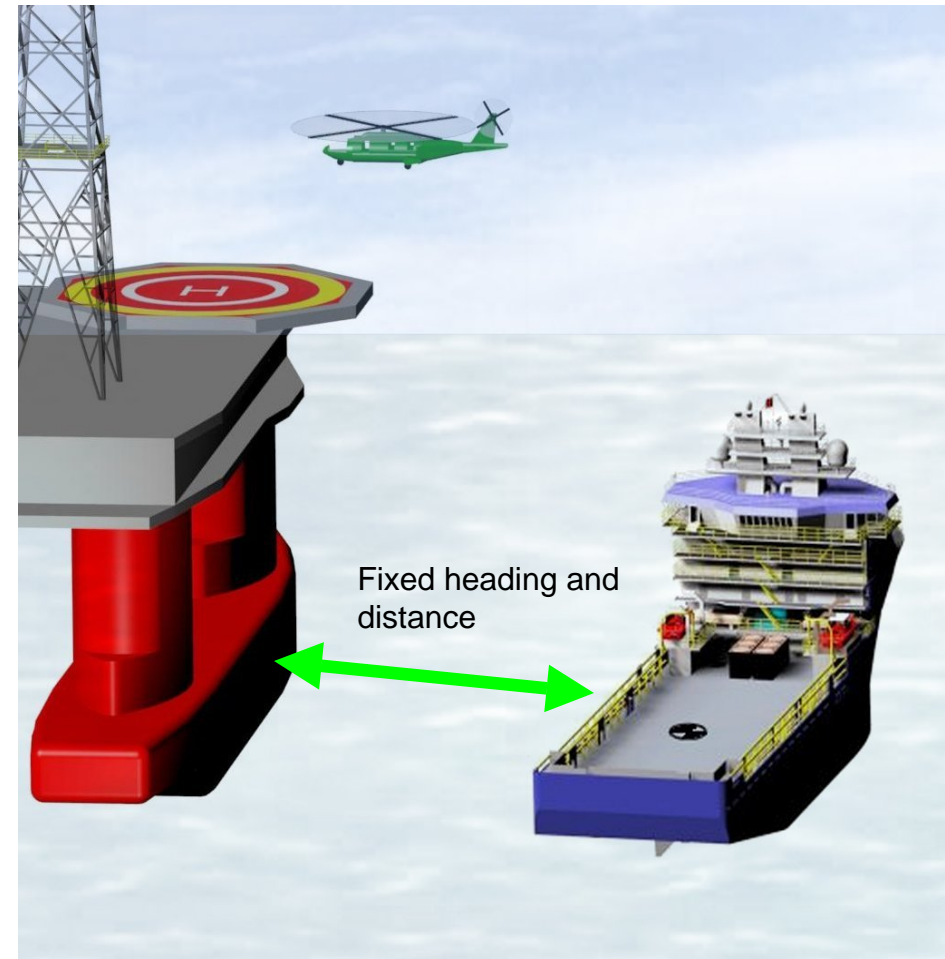

Customised Technology for Customer Success

- For DP a reliable, continuous and accurate position measurement equipment (PME) is required.
- For Class II and III operation, 3 PMEs are required with 2 measuring techniques.
 - OSV's typically have two absolute and one relative position reference systems
 - Drilling Rigs typically have two DGPS/Glonass and two dual acoustics (USBL/LBL)

Class II/III triple voting system

APC

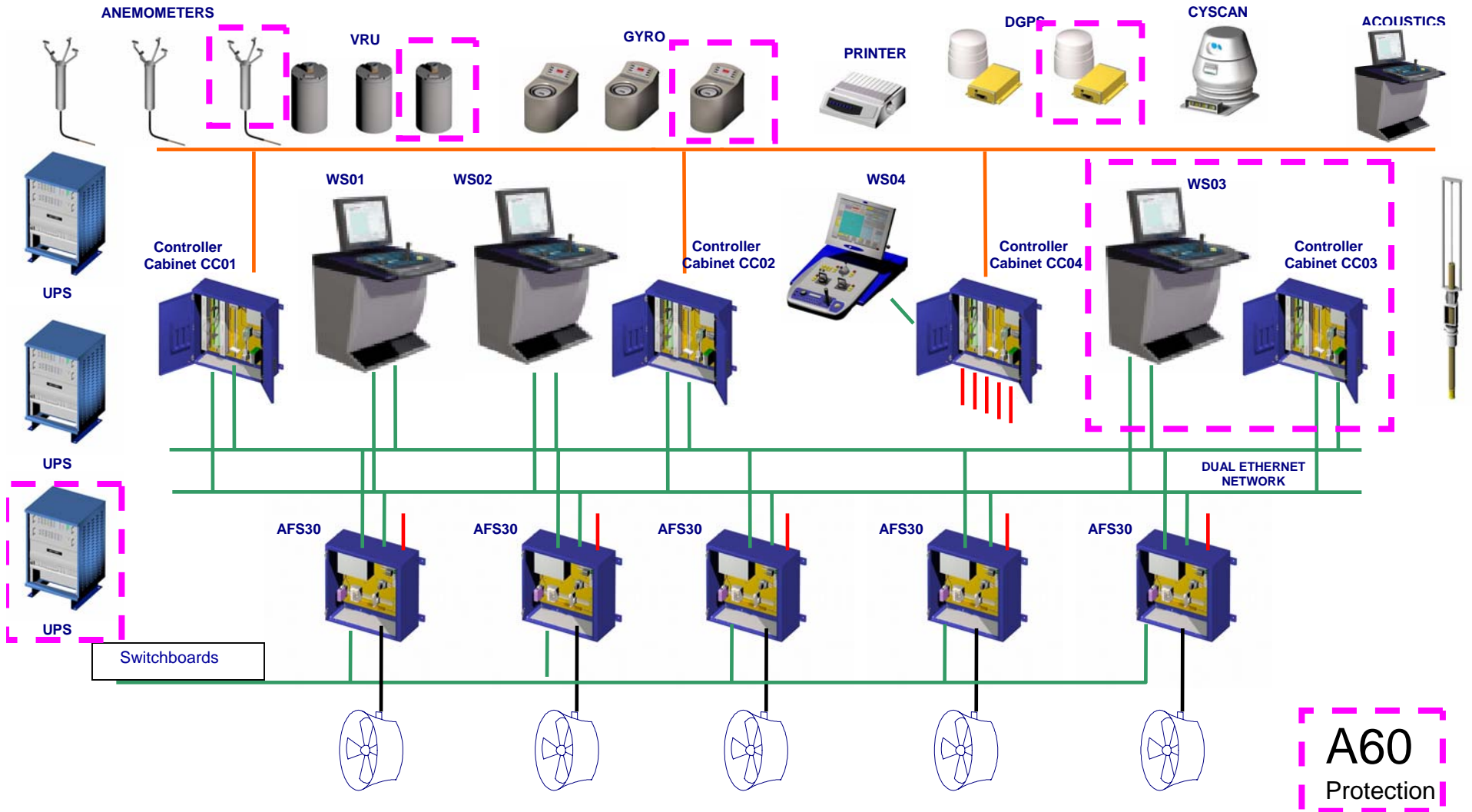

Customised Technology for Customer Success

- Independent PMEs must not have a common mode of failure.
 - multiple (D)GPS systems are not really independent
- Better safety could be achieved with a wider range of available independent PMEs

- Common PME's used for DP include:-
 - Acoustics
 - DGPS
 - Taut wire
 - Laser systems:
 - CyScan
 - Fanbeam
 - Radar systems
- Other options include:-
 - Darps/Artemis
 - Inertial navigation system (INS)

- Common PME's used for DP include:-
 - Acoustics
 - DGPS
 - Taut wire
 - Laser systems:
 - CyScan
 - Fanbeam
 - Radar systems
- Other options include:-
 - Darps/Artemis
 - Inertial Navigation System



Customised Technology for Customer Success

- Common PME's used for DP include:-
 - Acoustics
 - **DGPS**
 - Taut wire
 - Laser systems:
 - CyScan
 - Fanbeam
 - Radar systems
- Other options include:-
 - Darps/Artemis
 - Inertial Navigation System



- Common PME's used for DP include:-
 - Acoustics
 - DGPS
 - Taut wire
 - Laser systems:
 - CyScan
 - Fanbeam
 - Radar systems
- Other options include:-
 - Darps/Artemis
 - Inertial Navigation System



Customised Technology for Customer Success

- Common PME's used for DP include:-
 - Acoustics
 - DGPS
 - Taut wire
 - Laser systems:
 - CyScan
 - Fanbeam
 - Radar systems
- Other options include:-
 - Darps/Artemis
 - Inertial Navigation System



Customised Technology for Customer Success

- Common PME's used for DP include:-
 - Acoustics
 - DGPS
 - Taut wire
 - Laser systems:
 - CyScan
 - Fanbeam
 - Radar systems
- Other options include:-
 - Darps/Artemis
 - Inertial Navigation System



Customised Technology for Customer Success

- Common PME's used for DP include:-
 - Acoustics
 - DGPS
 - Taut wire
 - Laser systems:
 - CyScan
 - Fanbeam
 - Radar systems
- Other options include:-
 - Darps/Artemis
 - Inertial Navigation System

EXPENSIVE TO OSV AND RIG

SETUP TIME

TRAINING ON OSV AND RIG

DEDICATED

- Common PME's used for DP include:-
 - Acoustics
 - DGPS
 - Taut wire
 - Laser systems:
 - CyScan
 - Fanbeam
 - Radar systems
- Other options include:-
 - Darps/Artemis
 - Inertial Navigation System

MEDIUM TO HIGH COST

INITIAL SETUP TIME

MINIMAL TRAINING

DEDICATED

**OFFERS OTHER
INFORMATION ON
HEADING/PITCH/ROLL/
POSITION AIDED**

Limitations

APC

- Each PME type is subject to limitations
 - GPS: ionospheric interference
 - GPS: rig shadowing satellites
 - GPS: correction updates can be up to 60 seconds
- Deep water introduces problems:
 - acoustics noise and update rate
 - taut wire not available
- Laser Systems
 - short range
 - line of sight
 - weather (snow, fog)



Customised Technology for Customer Success

- Dual axis Doppler log
 - known/proven product used by mariners on larger vessels
 - velocity information for bottom and water track
 - surge and sway axes
 - independent of other PME's
 - back up for PME failure
 - 'fill-in' for slow acoustic update rates
 - used in Kalman filter to estimate vessel velocity and position
 - provides useful information to the operators for normal manual operations
- Why use this type of measurement?
 - Past history with cable layers using Doppler log with auto speed mode

- The KF structure allows Doppler measurements to be utilised in a straightforward manner to give optimal estimates of vessel state.
- Properties of the measurement system can be built into the model for improved accuracy.
- For water lock, estimation of current (velocity offset) is easily included.

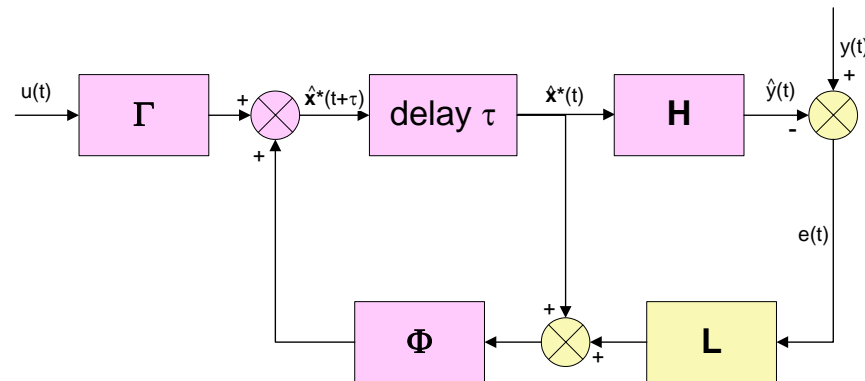

- Offsets identified in the DP system
- Not 'tightly coupled' to (D)GPS
- Fault detection is included in DP system
- Fault tolerant strategies are required to avoid corruption of velocity estimates

Dependent PME

APC

- PME directly communicates with GPS
 - PME system calculates offsets
 - Combined position sent to DP
 - Cannot be considered independent of GPS
-
- INS falls into this category

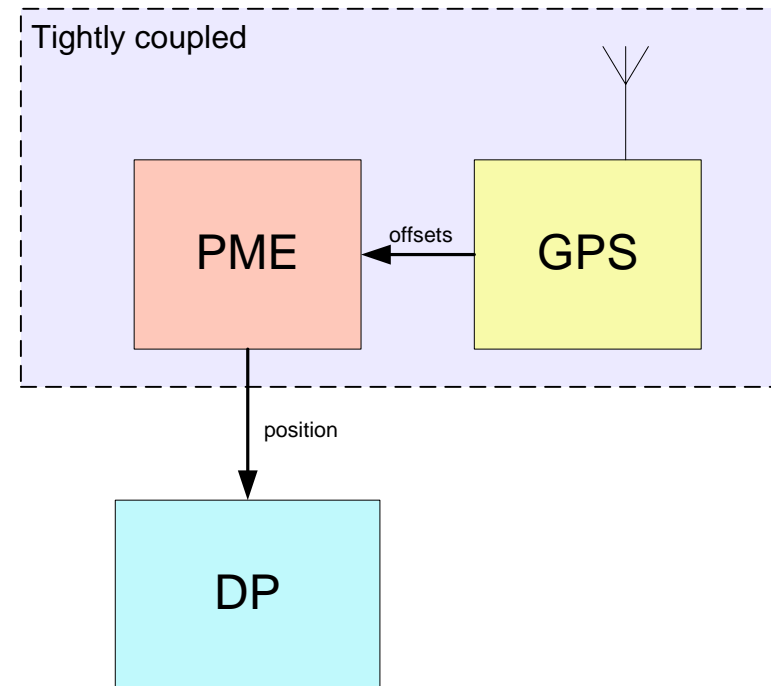

Customised Technology for Customer Success

Independent PME

APC

- No interconnection between PME and GPS
- DP system calculates offsets
- DP system performs fault detection
- DP system has the ability to reconfigure when a fault is detected

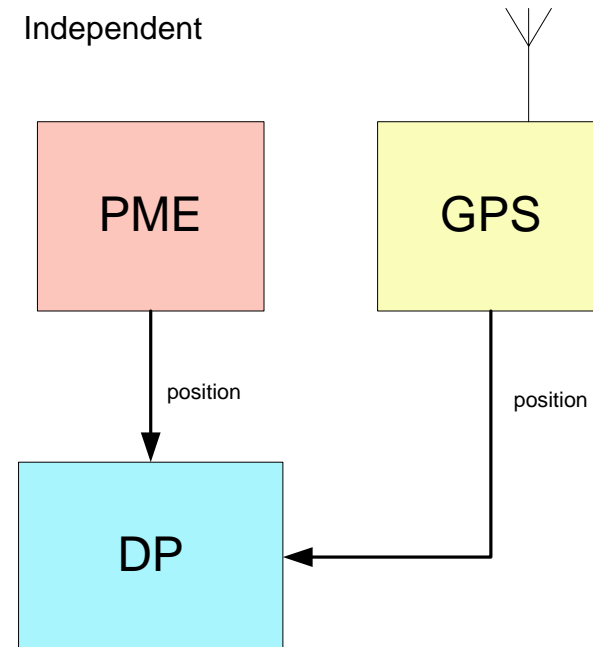

Customised Technology for Customer Success

- Simulation results
 - Monte Carlo multiple runs
 - randomly generated starting conditions
 - DGPS fails after 100 s

No PME

APC

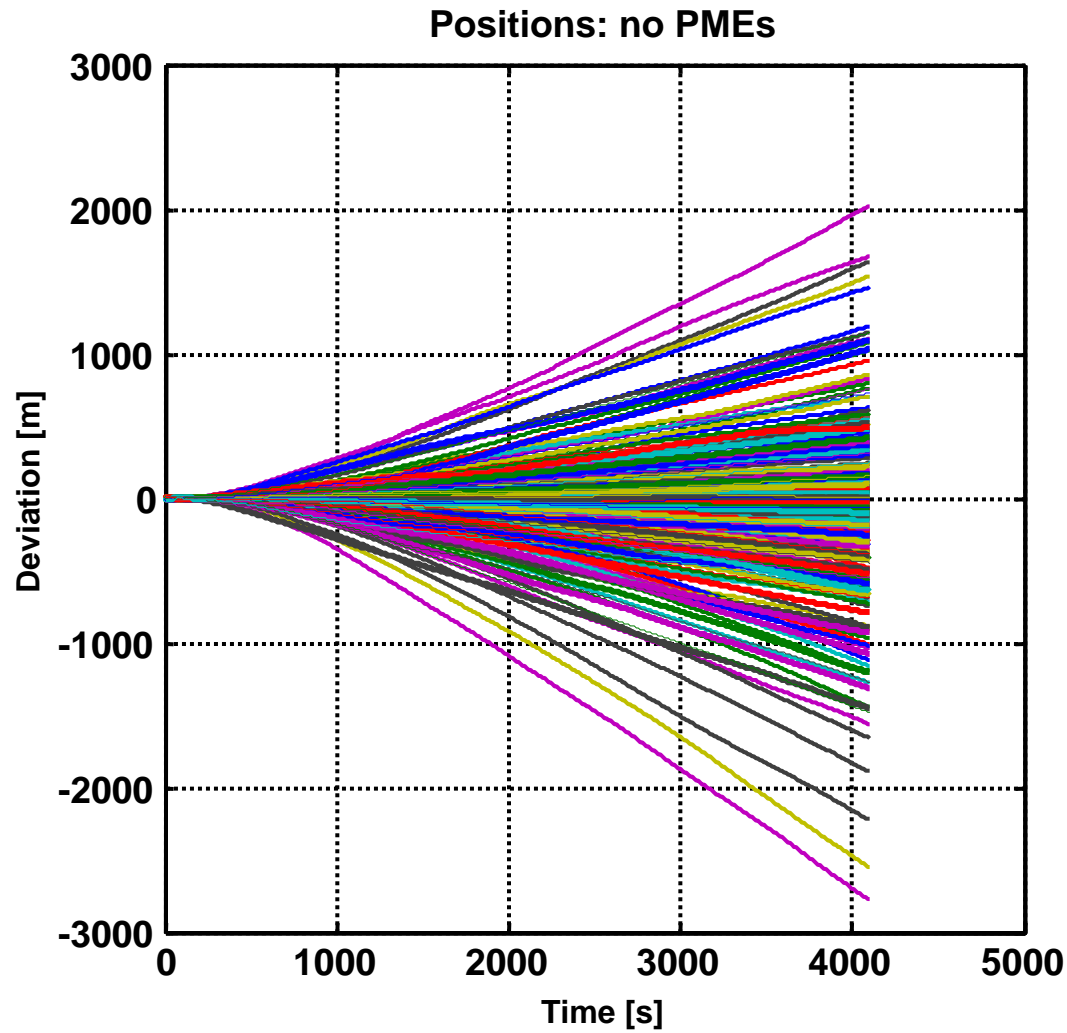

Customised Technology for Customer Success

APC Rugby/MTS DPC Houston/RS

Doppler available

APC

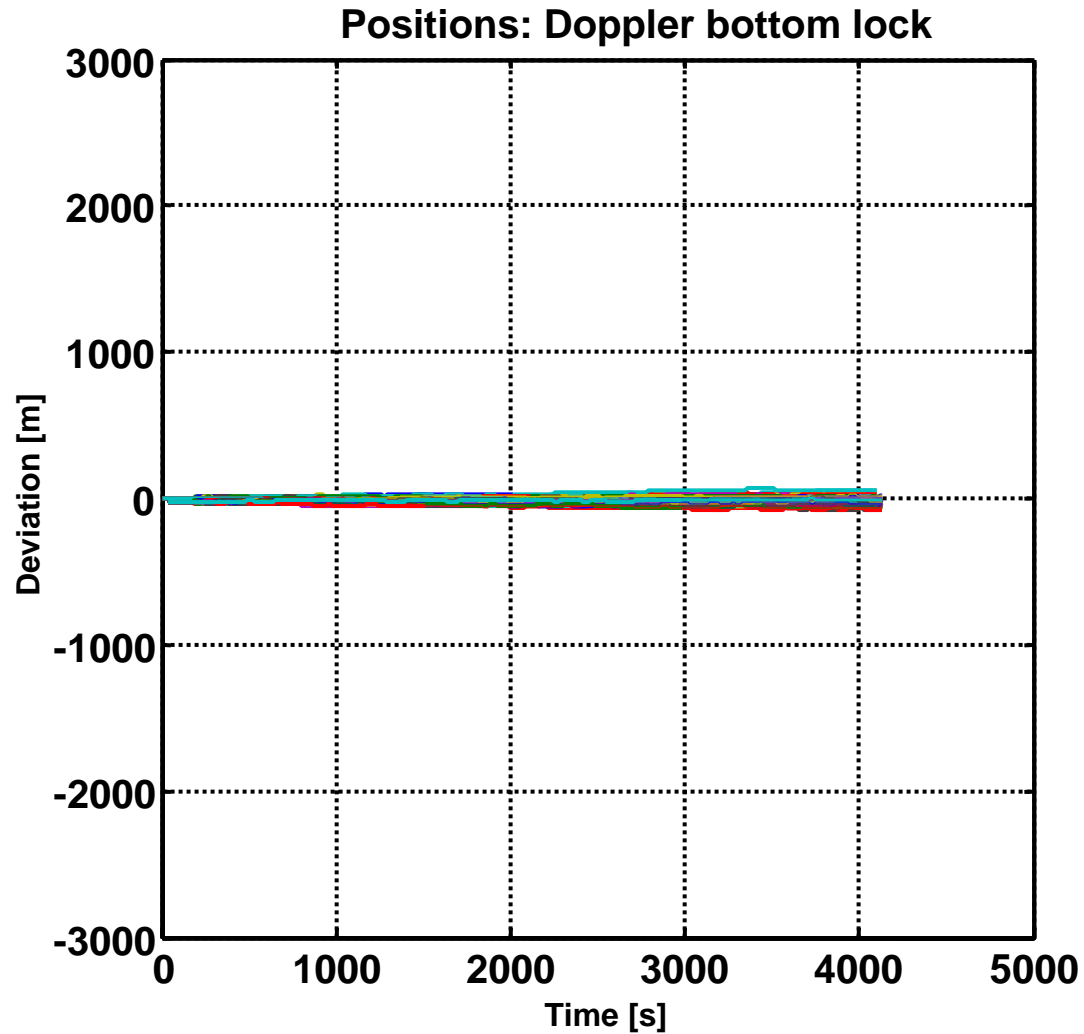

Customised Technology for Customer Success

Doppler available (expanded)

APC

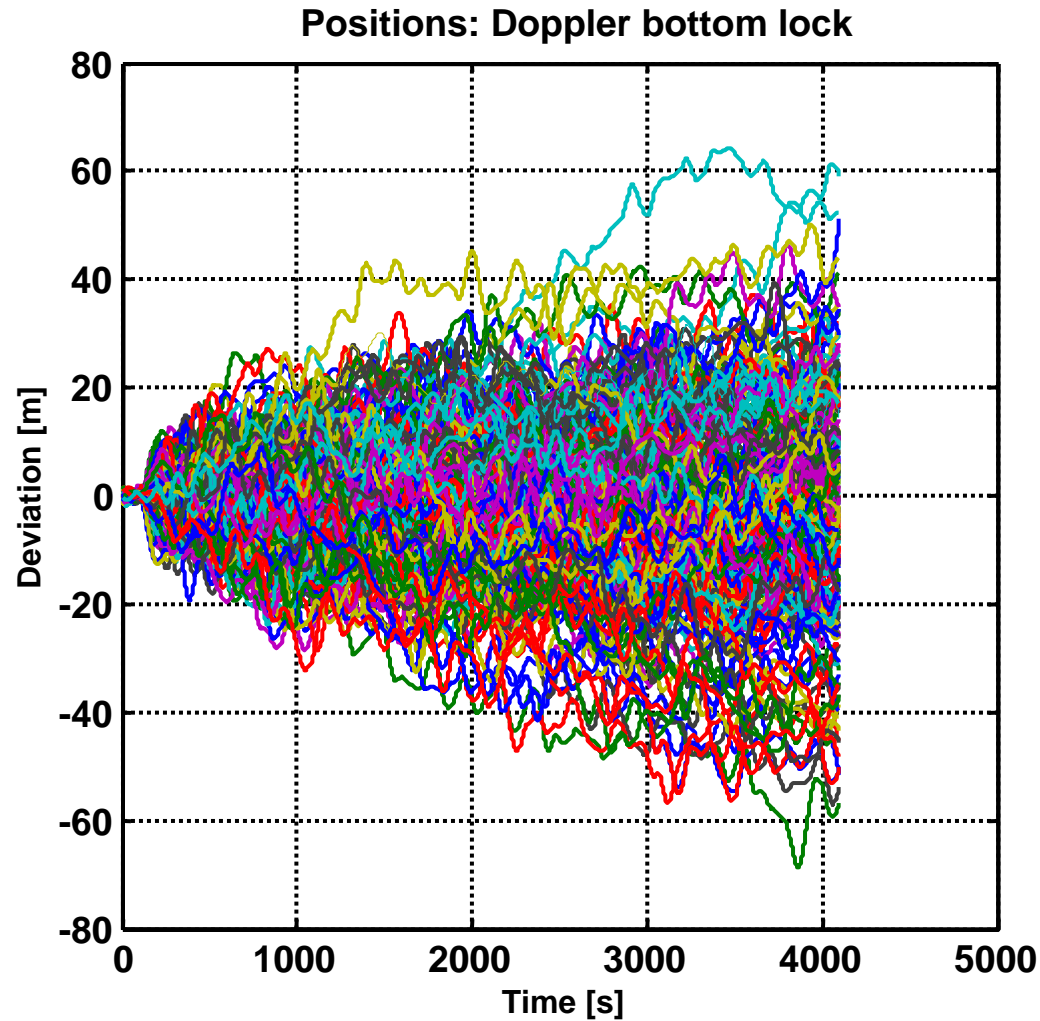

Customised Technology for Customer Success

APC Rugby/MTS DPC Houston/RS

Distribution of errors

APC

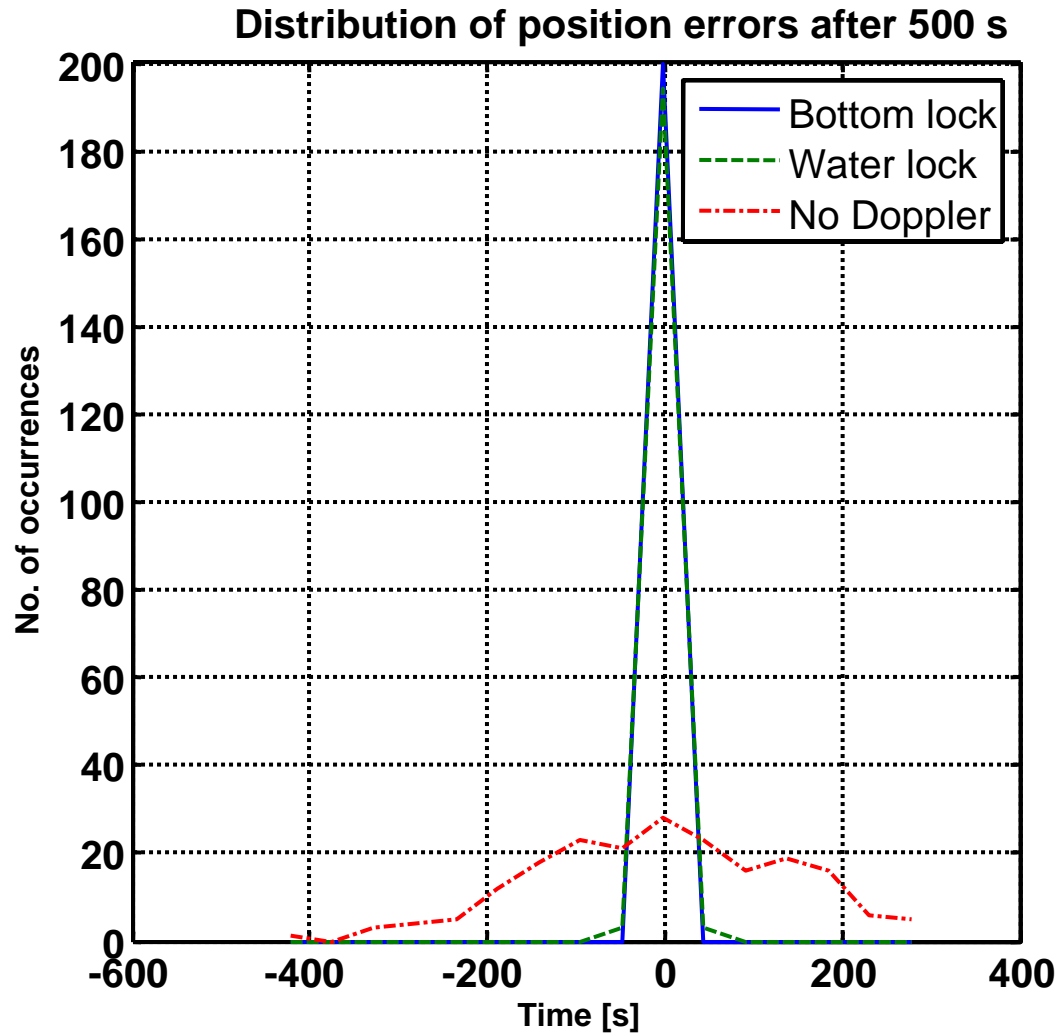

Customised Technology for Customer Success

Distribution of errors

APC

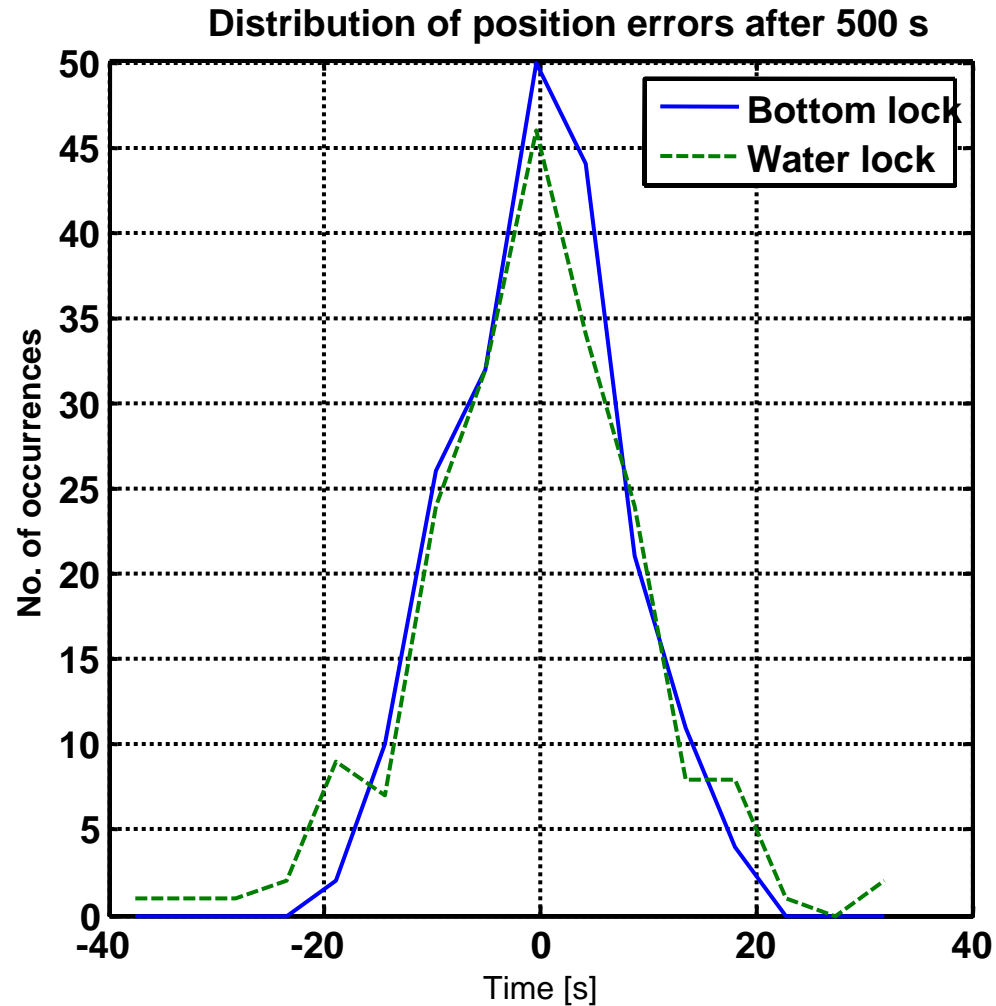

Customised Technology for Customer Success

Deviations after 500 s

APC

Measurement type	Position error std. dev. (m)
DGPS	1.2
Bottom lock	7.7
Water lock	10.3
None	138.8

Customised Technology for Customer Success

Errors after 1 hour

APC

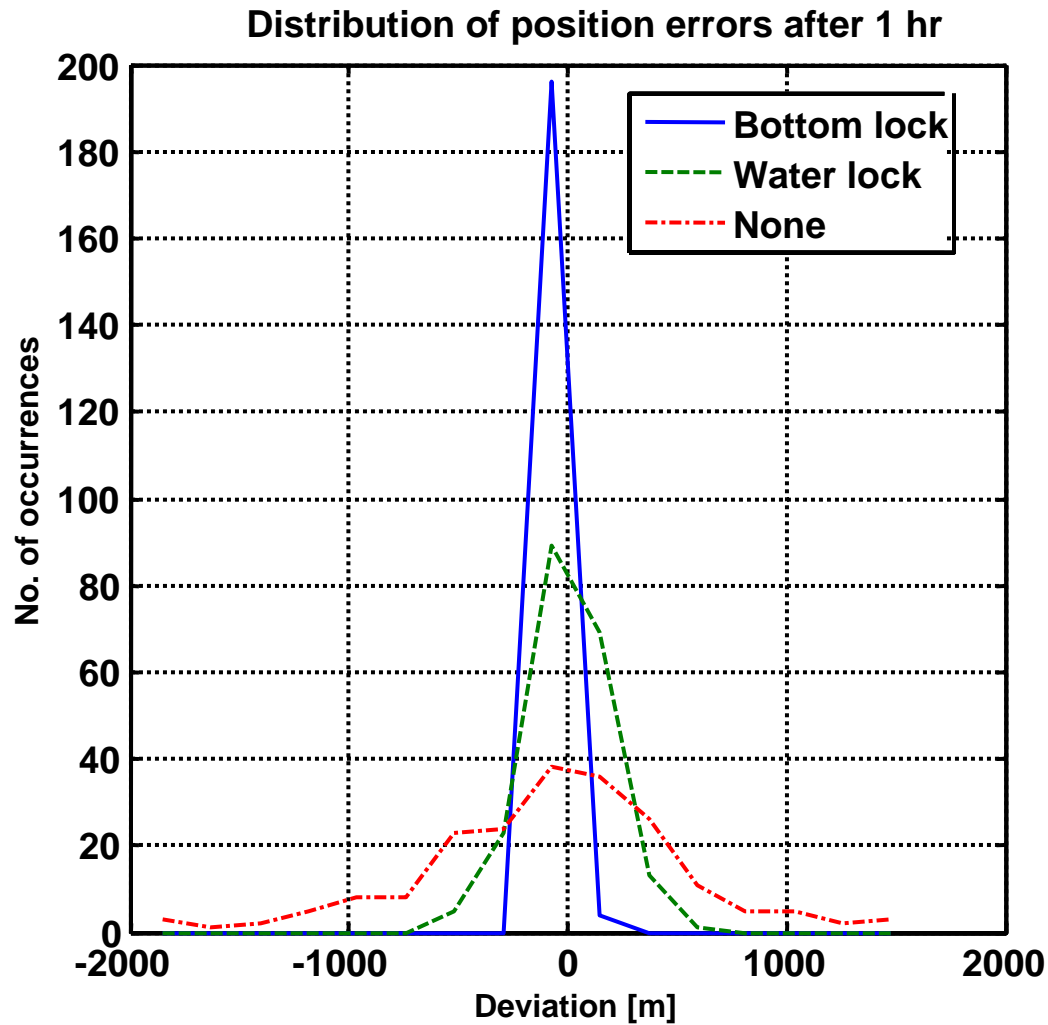

Customised Technology for Customer Success

- Measurements acquired from real ship.
- GPS and Doppler measurements available.
- Measurements from both taken during DP.
- Simulation runs performed using each measurement compared to no PME.

Velocity measurements

APC

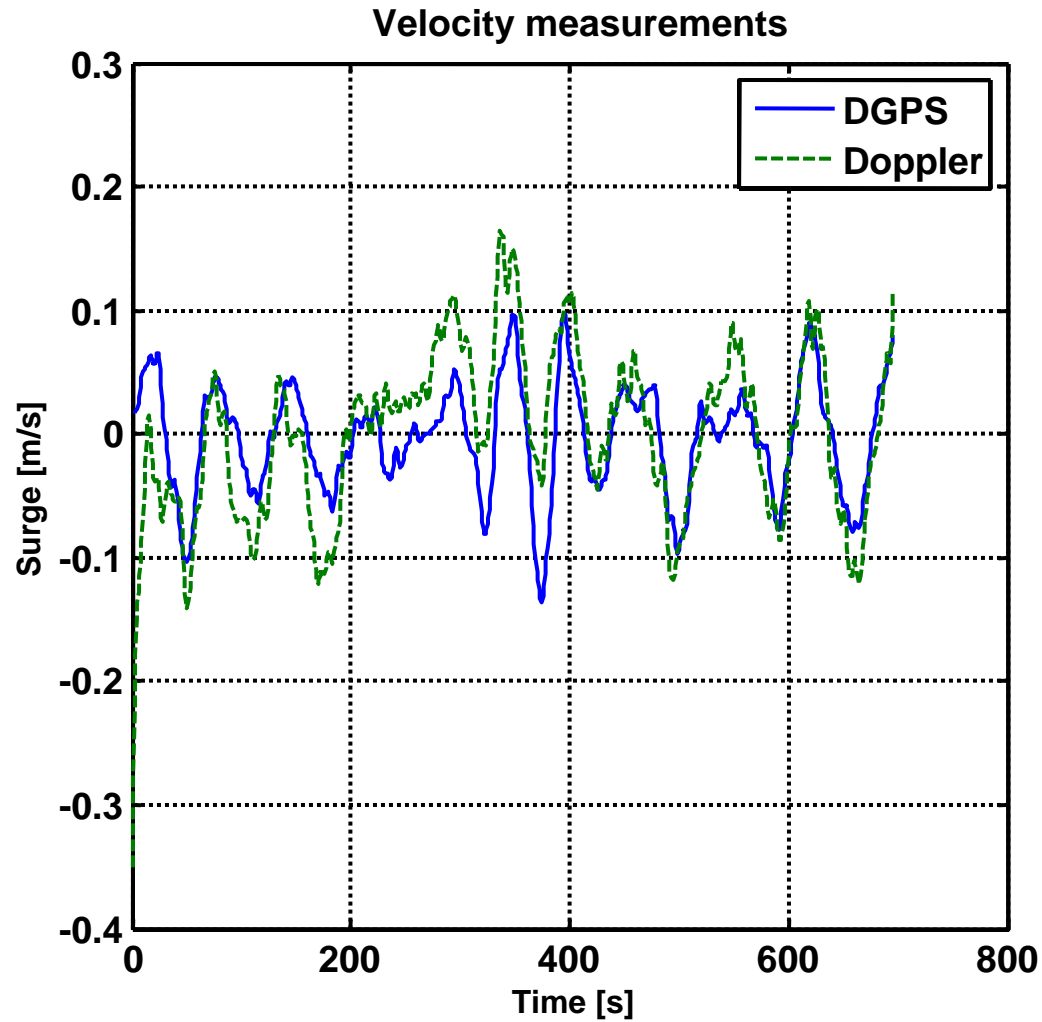

Customised Technology for Customer Success

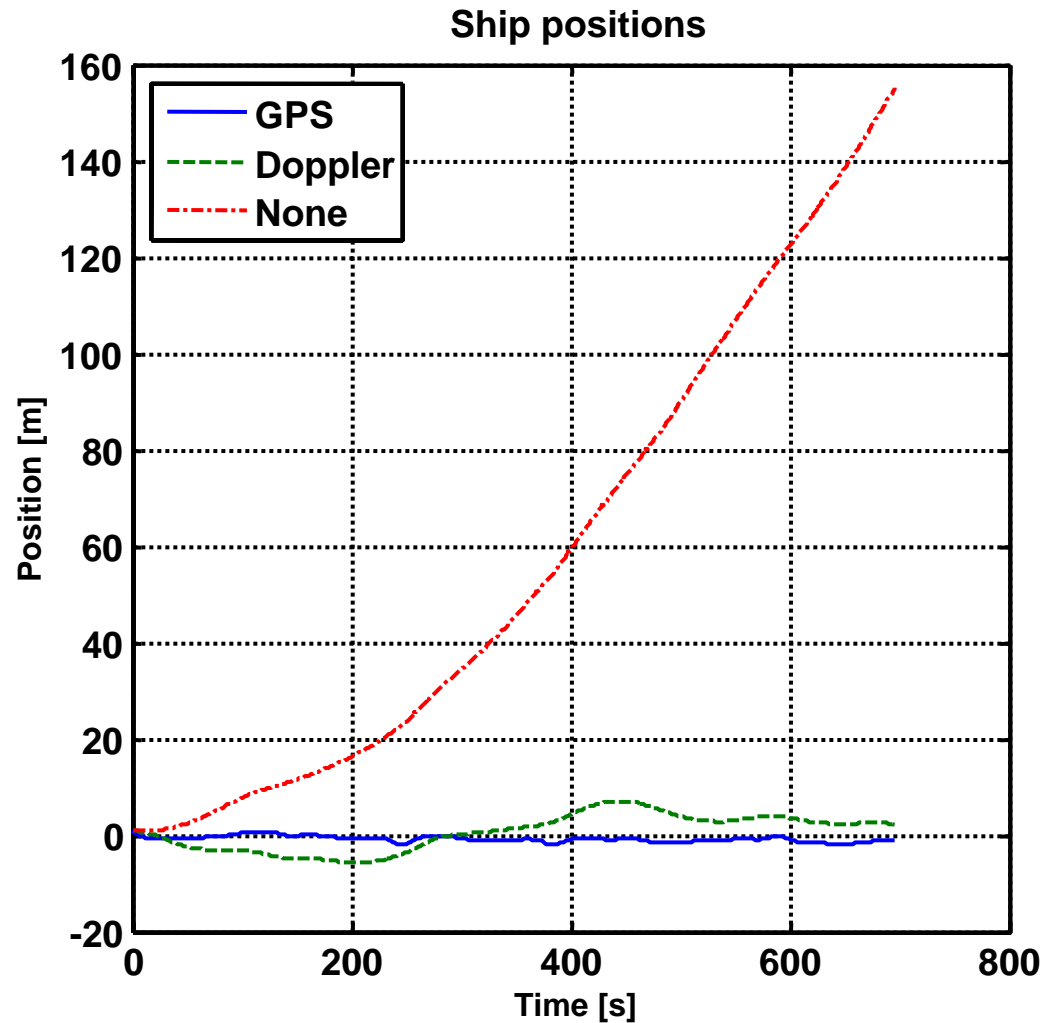

Customised Technology for Customer Success

- The more PME's the better (position and velocity)
- PME's must be independent
- The best place to combine measurements is the DP system itself
- Doppler logs can provide useful backup for PME failure
 - for over an hour on bottom lock (actual figures to be confirmed)
 - for minutes on water lock (actual figures to be confirmed)
- Dopplers logs give the operator an indication of fore/aft and port/stbd velocity (another visual aid) for automatic and manual manoeuvring
- Full scale trials are under way
- Follow up talks with INS manufacturers