



Control Systems II

**HIERARCHICAL PRINCIPLE of CONSTRUCTION of
SPATIAL DYNAMIC POSITIONING (DP) SYSTEMS of SEA MOBILE OBJECTS (SMO)**

S.K.Volovodov

Saint-Petersburg State University of Ocean Technology and Fund "Shipbuilding".

Dynamic Positioning Conference

November 15-16, 2005

-task of DP SMO in space at performance of saving works;

-task of DP of underwater vehicles and robots in space at performance

of different works on shelf and many others similar works.

The statement of task

- *The basic idea of approach consist in using of two levels control of DP:*
- -at first level (named top level) System of DP define vectors of control force F_{con} and moment M_{con} ;
- -at second level (named bottom level) System of DP distribute this vectors on thrusters.

For forming Lyapunov function the next deviations are used :

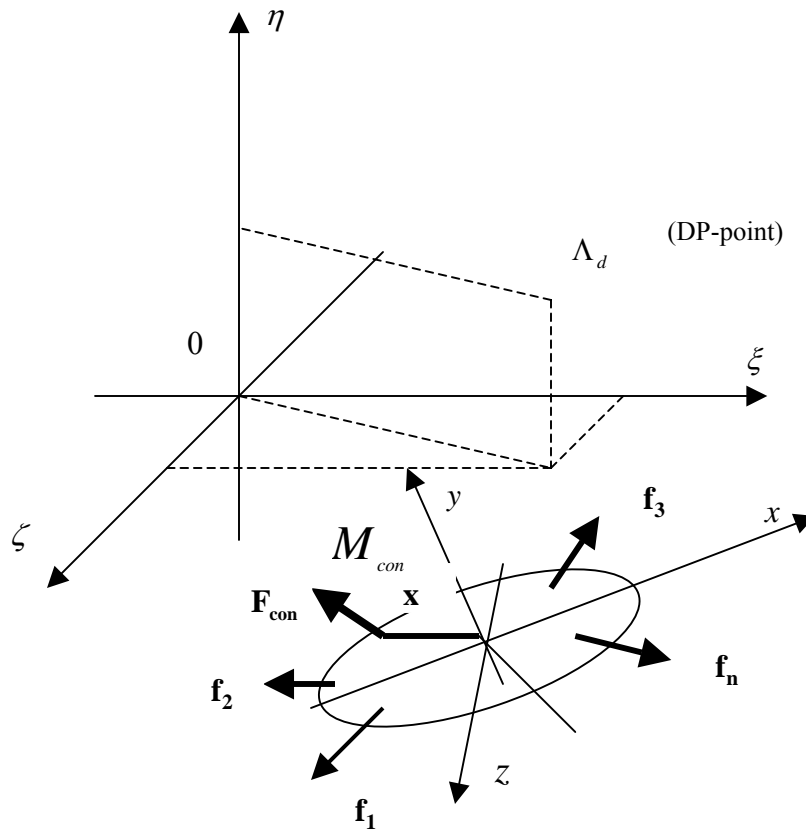

$$s_1 = v - v_d \quad v_d = 0, \quad s_1 = v$$

$$s_2 = \Lambda - \Lambda_d$$

$$v^T = (v_x, v_y, v_z, \omega_x, \omega_y, \omega_z)$$

$$\Lambda^T = (\xi, \eta, \zeta, \theta, \varphi, \psi)$$

top level of control consist in definition

$$L_{con} = [F_{con}, M_{con}] = ?$$

$$M_{con} = \mathbf{x} \cdot \mathbf{F}_{con}$$

bottom level of control

consist in decision of

the next vector equations

$$\mathbf{F}_{con}(t) = \sum_{i=1}^N \mathbf{f}_i(t); \quad \mathbf{f}_i = ?$$

$$\mathbf{M}_{con}(t) = \sum_{i=1}^N \mathbf{x}_i \cdot \mathbf{f}_i(t).$$

Control of top level

• *For definition of control laws of top level the next equations of motion SMO are used:*

$$M\dot{v} + C(v)v + D(v)v + g(\Lambda) = L_{con} + L_w, \quad v^T = (v_x, v_y, v_z, \omega_x, \omega_y, \omega_z) \quad \Lambda = (\xi, \eta, \zeta, \theta, \varphi, \psi),$$

Matrix of Corioliss and centripetal forces

$$\dot{\Lambda} = H(\Lambda)v,$$

$$C(v) = \begin{bmatrix} A \\ B \end{bmatrix} \quad A = \begin{bmatrix} 0 & -m_y\omega_z & m_z\omega_y & 0 & 0 & 0 \\ m_x\omega_z & 0 & -m_z\omega_x & 0 & 0 & 0 \\ -m_x\omega_y & m_y\omega_x & 0 & 0 & 0 & 0 \end{bmatrix} \quad B = \begin{bmatrix} 0 & 0 & 0 & 0 & 0 & 0 \\ (m_x - m_z)v_z & 0 & 0 & (J_x - J_z)\omega_z & 0 & 0 \\ 0 & (m_y - m_x)v_x & 0 & 0 & (J_y - J_x)\omega_x & 0 \end{bmatrix}$$

$D(v)$ – Matrix of hydrodynamic forces

Vector of weight and displacement forces

$$g(\Lambda)^T = [(Q - G) \sin \psi, (Q - G) \cos \psi \cos \theta, -(Q - G) \cos \psi \sin \theta, -Q(z_o \cos \psi \cos \theta + y_o \cos \psi \sin \theta), Q(x_o \cos \psi \cos \theta - y_o \sin \psi), Q(x_o \cos \psi \sin \theta + z_o \sin \psi)],$$

Matrix of cinematic connections

$$H(\Lambda) = \begin{bmatrix} R & 0 \\ 0 & S \end{bmatrix}, \quad R = \begin{bmatrix} \cos \varphi \cos \psi & \sin \theta \sin \varphi - \cos \theta \cos \varphi \sin \psi & \cos \theta \sin \varphi + \sin \theta \cos \varphi \sin \psi \\ \sin \psi & \cos \theta \cos \psi & -\sin \theta \cos \psi \\ -\sin \varphi \cos \psi & \sin \theta \cos \varphi + \cos \theta \sin \varphi \sin \psi & \cos \theta \cos \varphi - \sin \theta \sin \varphi \sin \psi \end{bmatrix} \quad S = \begin{bmatrix} 1 & -\cos \theta \operatorname{tg} \psi & \sin \theta \operatorname{tg} \psi \\ 0 & \frac{\cos \theta}{\cos \psi} & -\frac{\sin \theta}{\cos \psi} \\ 0 & \frac{\cos \psi}{\sin \theta} & \frac{\cos \psi}{\cos \theta} \end{bmatrix}$$

Control of top level1

- *Method of synthesis*

For designing of control law (first stage) next Lyapunov function candidate are used

$$V = \frac{1}{2} \{s_1^T M s_1 + s_2^T K_2 s_2\} \quad \text{control system stable, if } \dot{V} < 0, \text{ whence follows}$$

$$L_{con} = C(v)v + D(v)v + g(\Lambda) - K_1 v - H^T(y)K_2(\Lambda - \Lambda_d) \quad \text{and} \quad K_1 > 0, K_2 > 0.$$

Matrix K_1, K_2 determine time of transfer processes t_p for little $y(\theta, \varphi, \psi)$

For designing the observer (second stage) next equations are used

$$M\dot{\hat{v}} = -K_1 \hat{v} - H^T(y)K_2(\hat{\Lambda} - \Lambda_d) + \bar{K}_2(\Lambda - \hat{\Lambda}),$$

$$\dot{\hat{\Lambda}} = H(y)\hat{v} + \bar{K}_1(\Lambda - \hat{\Lambda}), \quad y = (\theta, \varphi, \psi).$$

Lyapunov function candidate look as

$$W = \frac{1}{2} (\tilde{v}^T M \tilde{v} + \tilde{\Lambda}^T Q_2 \tilde{\Lambda}), \quad \text{where } \tilde{v} = v - \hat{v}, \tilde{\Lambda} = \Lambda - \hat{\Lambda}.$$

observer stable, if $\dot{W} < 0$, whence follows

$$\bar{K}_2 = H^T(y)Q_2^T, \bar{K}_1 > 0, D - L > 0,$$

L - Lipschitz const. for $C(v)$.

Control of top level2

- ***The final stage of synthesis consist in estimation of stability of controlled motion SMO with observer***

For this purpose consider the equations of control motion of SMO in estimations (assume, that errors of estimation for stable observer too little)

$$M\dot{\hat{v}} = -K_1\hat{v} - H^T(y)K_2(\hat{\Lambda} - \Lambda_d) + \bar{K}_2\tilde{\Lambda},$$

$$\dot{\hat{\Lambda}} = H(y)\hat{v} + \bar{K}_1\tilde{\Lambda}.$$

Equations for estimation errors of observer

$$M\dot{\tilde{v}} = -(C(v)v - C(\hat{v})\hat{v}) - D\tilde{v} - \bar{K}_2\tilde{\Lambda},$$

$$\dot{\tilde{\Lambda}} = H(y)\tilde{v} - \bar{K}_1\tilde{\Lambda}.$$

Lyapunov function candidate

$$S = \frac{1}{2}(\tilde{v}^T M\tilde{v} + \hat{\Lambda}^T Q_1\hat{\Lambda} + \tilde{v}^T M\tilde{v} + \tilde{\Lambda}^T Q_2\tilde{\Lambda})$$

$$Q_1 = \text{diag}\{q_{1i}\} > 0, Q_2 = \text{diag}\{q_{2i}\} > 0$$

Control motion stable if $\dot{S} < 0$, whence follows

$K_2 = Q_1^T, \bar{K}_2 = H^T(y)Q_2^T, K_1 > 0, D - L > 0$, these conditions coincide with previous and

$$\bar{K}_1 = \text{diag}\{\bar{k}_{1i} = \frac{3q_{2i}}{q_{1i}t_p}\}, \text{ that follows from } \hat{\Lambda}^T Q_2^T + \Lambda^T Q_1 \bar{K}_1 = 0, \Lambda_i = Ce^{-\frac{q_{1i}\bar{k}_{1i}t}{q_{2i}}},$$

additional conditions of concording time of transfer processes of SMO control motion and estimation.

Control of bottom level

- **Consist in decision of task of distribution $L_{con}(F_{con}, M_{con})$ on thrusters,** that equals to decision next system of vector equations (six scalar equations)

$$\mathbf{F}_{con}(t) = \sum_{i=1}^N \mathbf{f}_i(t);$$

$$\mathbf{M}_{con}(t) = \sum_{i=1}^N \mathbf{x}_i \cdot \mathbf{f}_i(t).$$

$$\mathbf{f}_i = ? \quad (a)$$

This system may have:

- no decision (system not controllability);
- solo decision;
- infinitive quantity of decisions.

$$\mathbf{x}_i = \begin{bmatrix} 0 & -z_i & y_i \\ z_i & 0 & -x_i \\ -y_i & x_i & 0 \end{bmatrix} \quad - \text{skew-symmetric matrix (special)}$$

Decisions (a) exist, if x_i and \mathbf{f}_i satisfy same conditions (criterion of controllability)

In case of infinitive quantity of decisions \mathbf{f}_i , additional condition are used

$$\min_{f_i} J = \min_{f_i} \frac{1}{2} \sum_{i=1}^N \lambda_i(t) \mathbf{f}_i^T(t) \mathbf{f}_i(t) \quad (\text{criterion of min power})$$

Such approach allows to connect all thrusters in united (integrated) control system of DP

Control of bottom level1

• **Existing of decisions (solo or infinitive) are determined by criterion of controllability:**

SMO is controlled, if the coordinates of an arrangement of any six thrusters (two groups with three thrusters) with tractions directed along axes (see figure) satisfy to conditions:

$$(x_3^{(1)} - x_3^{(2)}) \cdot (y_1^{(1)} - y_1^{(2)}) \cdot (z_2^{(1)} - z_2^{(2)}) - (x_2^{(1)} - x_2^{(2)}) \cdot (y_3^{(1)} - y_3^{(2)}) \cdot (z_1^{(1)} - z_1^{(2)}) \neq 0$$

and $x_3^{(1)} y_1^{(1)} z_2^{(1)} - x_2^{(1)} y_3^{(1)} z_1^{(1)} \neq 0$

or $x_3^{(2)} y_1^{(2)} z_2^{(2)} - x_2^{(2)} y_3^{(2)} z_1^{(2)} \neq 0$

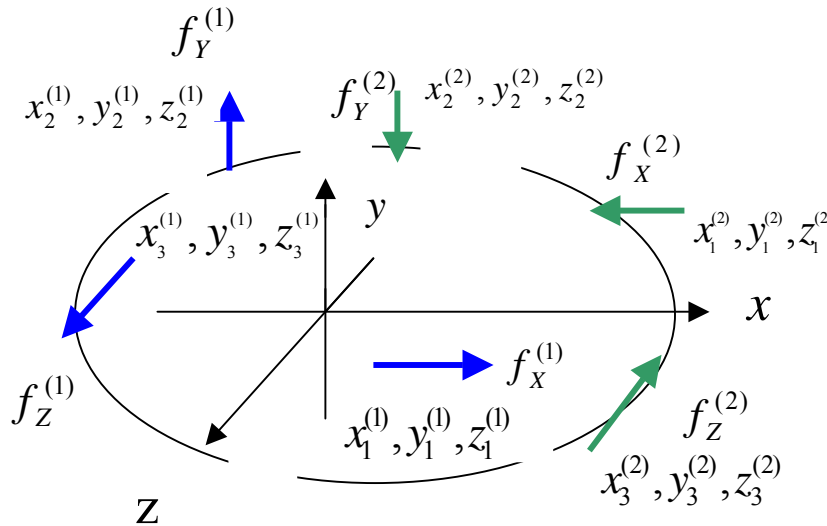

This conditions were concluded after substitution of coordinates of thruster arrangement in equations of task of distribution.

Putting of additional thrusters leads to infinitive quantity of decisions.

Example

- Consider the next scheme of an arrangement of thrusters

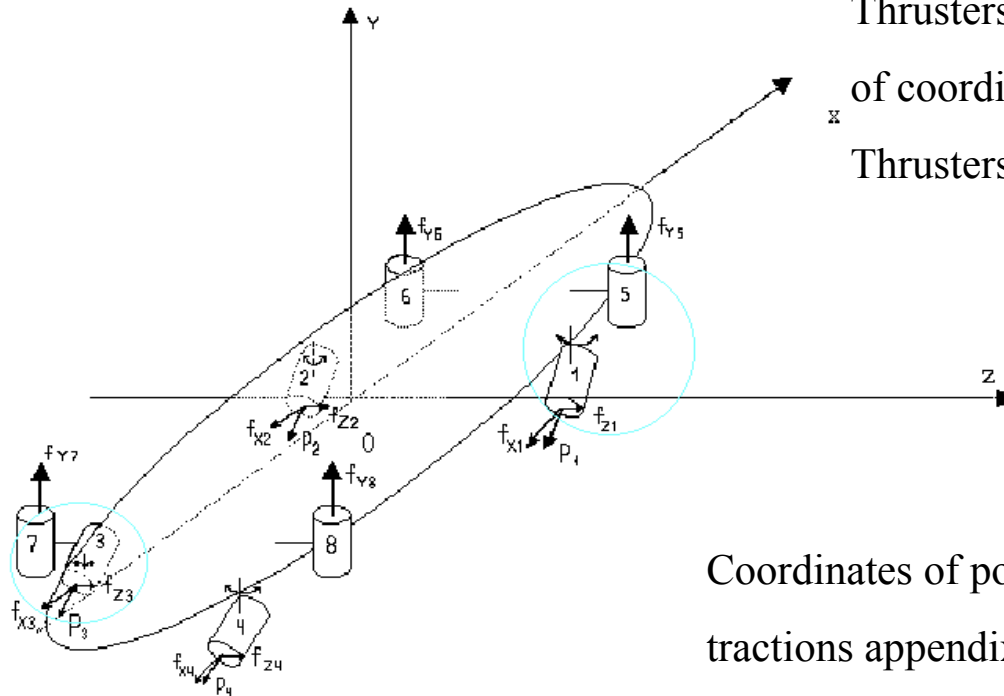

Thrusters 1-4 act in horizontal plane in b.f. system of coordinates and can rotate;
Thrusters 5-8 act along vertical axis.

Coordinates of points of the thruster tractions appendix have plane symmetry:

$$1(x_1, y_1, z_1); 2(x_1, y_1, -z_1); 3(-x_1, y_1, -z_1); 4(-x_1, y_1, z_1)$$

$$5(x_2, y_2, z_2); 6(x_2, y_2, -z_2); 7(-x_2, y_2, -z_2); 8(-x_2, y_2, z_2)$$

Example1

•The structure of DP control system

Angle of rotation of thrusters blades (5-8)

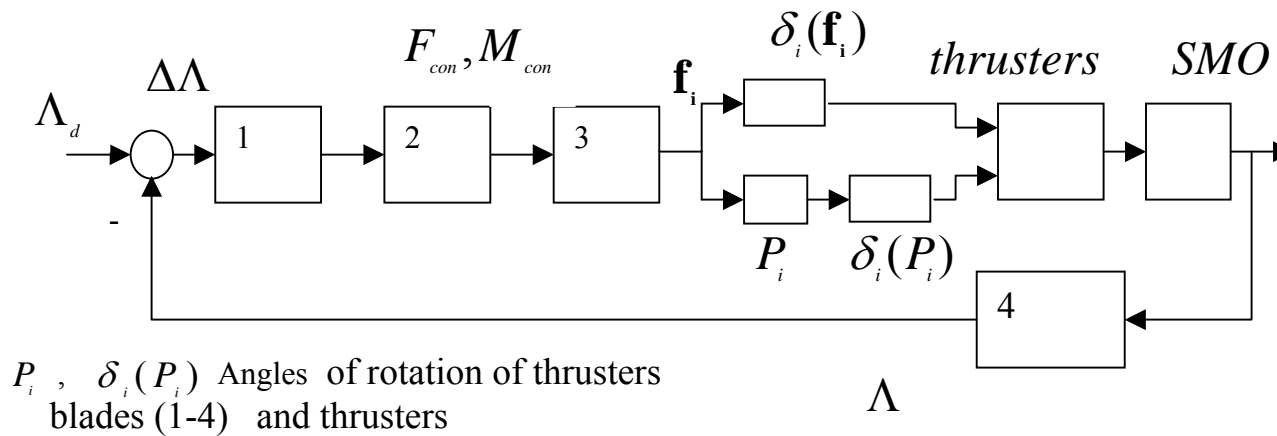

1. Task of determining of F_{con}, M_{con} in earth-fixed system coordinates
2. Re-count of F_{con}, M_{con} to body-fixed system coordinates
3. Task of Distribution of F_{con}, M_{con}
4. Re-count of body-fixed coordinates of SMO to earth-fixed system

Example2

- *Decision of vector equations of distribution Lcon on thrusters.*
- *Scalar form of equations of distribution for our example look as:*

$$f_{x1} + f_{x2} + f_{x3} + f_{x4} = F_{conx}$$

$$f_{y5} + f_{y6} + f_{y7} + f_{y8} = F_{cony}$$

$$f_{z1} + f_{z2} + f_{z3} + f_{z4} = F_{conz}$$

$$y_1(-f_{z1} - f_{z2} - f_{z3} - f_{z4}) + z_2(f_{y5} - f_{y6} - f_{y7} + f_{y8}) = M_{conx}$$

$$z_1(-f_{x1} + f_{x2} + f_{x3} - f_{x4}) + x_1(f_{z1} + f_{z2} - f_{z3} - f_{z4}) = M_{cony}$$

$$y_1(f_{x1} + f_{x2} + f_{x3} + f_{x4}) + x_2(-f_{y5} - f_{y6} + f_{y7} + f_{y8}) = M_{conz}$$

Simplify the equations by using the next designates

$$F_1 = f_{x2} + f_{x3}, \quad F_2 = f_{x1} + f_{x4}, \quad F_3 = f_{z1} + f_{z2}, \quad F_4 = f_{z3} + f_{z4},$$

$$F_5 = f_{y5}, \quad F_6 = f_{y6}, \quad F_7 = f_{y7}, \quad F_8 = f_{y8}$$

Then

$$F_1 + F_2 = F_{conx} \quad F_3 + F_4 = F_{conz} \quad z_1(F_1 - F_2) + x_1(F_3 - F_4) = M_{cony}$$

$$F_5 + F_6 + F_7 + F_8 = F_{cony} \quad F_5 - F_6 - F_7 + F_8 = \frac{1}{z_2}(M_{conx} + y_1 F_{conz}) \quad -F_5 - F_6 + F_7 + F_8 = \frac{1}{x_2}(M_{conz} - z_1 F_{conx}).$$

Example3

•**Decision of the task of distribution** . There are 8 unknown forces and 6 equations.

We can express F_1, F_2, F_3 as functions of F_4 , analogous F_5, F_6, F_7 as functions of F_8

$$F_1 = \frac{1}{2z_1}(M_{cony} + 2x_1F_4 - x_1F_{conz} + z_1F_{conx}), \quad F_2 = F_{conx} - \frac{1}{2z_1}(M_{cony} + 2x_1F_4 - x_1F_{conz} + z_1F_{conx}), \quad F_3 = F_y - F_4,$$

$$F_5 = \frac{1}{2}[F_{cony} + \frac{1}{z_2}(M_{conx} + y_1F_{conz})] - F_8, \quad F_6 = -\frac{1}{2}[\frac{1}{x_2}(M_{conz} - y_1F_{conx}) + \frac{1}{z_2}(M_{conx} + y_1F_{conz})] + F_8,$$

$$F_7 = \frac{1}{2}[F_{cony} + \frac{1}{x_2}(M_{conz} - y_1F_{conx})] - F_8$$

From condition $\min_{F_4, F_8} J = \min_{F_4, F_8} \frac{1}{2} \sum_{i=1}^8 \lambda_i F_i^2$ follows

$$F_4 = \frac{\lambda_3 F_{conz} + \lambda_2 \frac{x_1}{z_1} [F_{conx} - \frac{1}{2z_1} (M_{cony} - x_1 F_{conz} + y_1 F_{conx})] - \lambda_1 \frac{x_1}{2z_1^2} (M_{cony} - x_1 F_{conz} + z_1 F_{conx})}{(\lambda_1 + \lambda_2) \frac{x_1^2}{z_1^2} + \lambda_3 + \lambda_4}$$

$$F_8 = \frac{\lambda_5 [F_{cony} + \frac{1}{y_2} (M_{conx} + y_1 F_{conz})] + \frac{\lambda_6}{2} [\frac{1}{x_2} (M_{conz} - y_1 F_{conx}) + \frac{1}{z_2} (M_{conx} + y_1 F_{conz})] + \frac{\lambda_7}{2} [F_{cony} + \frac{1}{x_2} (M_{conz} - y_1 F_{conx})]}{\lambda_5 + \lambda_6 + \lambda_7 + \lambda_8}$$

Example4

- **Results of simulation for SMO**

with Displacement 800 tonns, thruster traction limited by 4E4 N.

Managing forces and moments are defined by

$$K_1 = \text{diag} (k_{1i})M , K_2 = \text{diag} (k_{2i})M , \quad k_{1i} = 20, k_{2i} = 1, \quad t_{tp} = 60c.$$

It is supposed presence of uniformly noise on interval ± 1 m for linear and $\pm 0.1^\circ$ for angular coordinates. Allowable DP errors is provided at

$$\bar{K}_2 = \text{diag}\{1,1,1,1E4,10,1E4\} \quad \bar{K}_1 = \text{diag}\{0.05;0.05;0.05;500;0.5;500\}$$

Results of filtration of signals

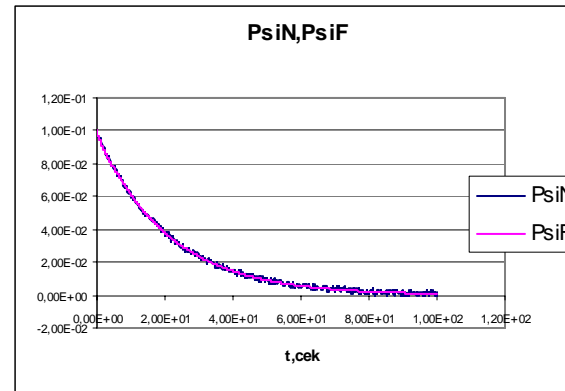
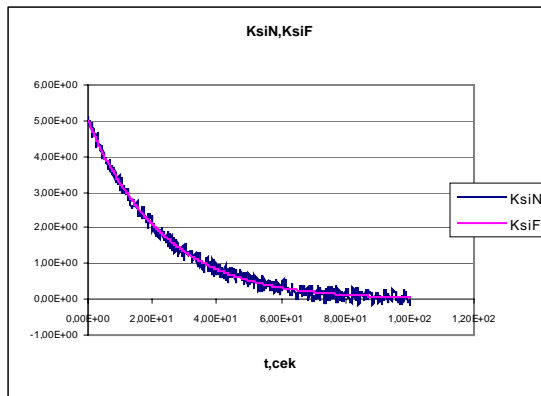

Example5

- *Results of simulation of control motion*
- *On this figures are shown results of simulation control processes with:*
Initial deviations on linear coordinates - 5 m, on angular - 0.1 rad. and
nonlimited tractions of thrusters

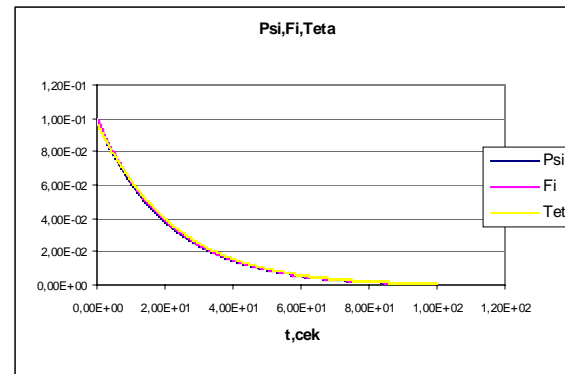
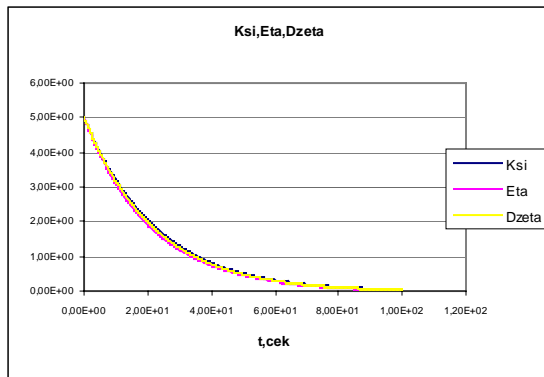

Tractions of thrusters are limited by 4E4 N.

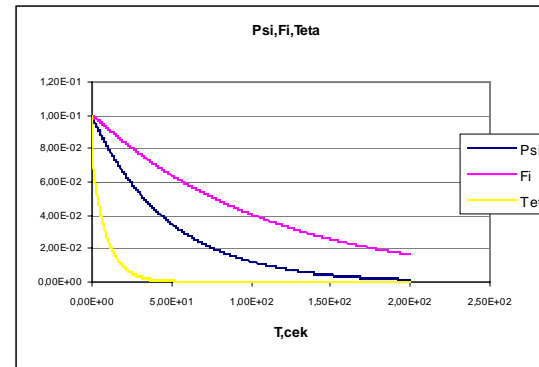
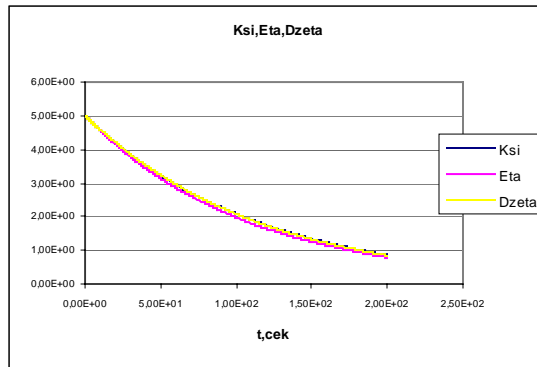

Example6

- Results of simulation of tractions**

The first (horizontal) group : tractions and angles of turn

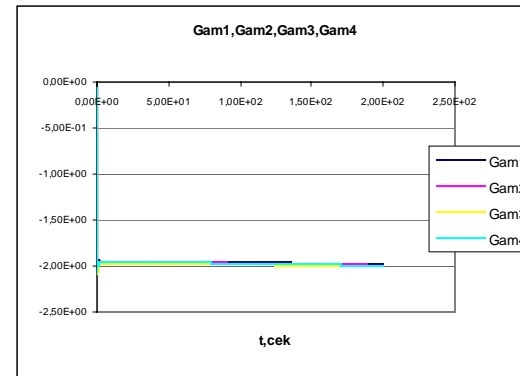
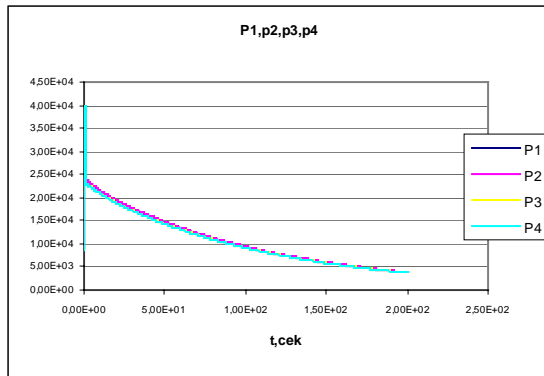

The second group : tractions

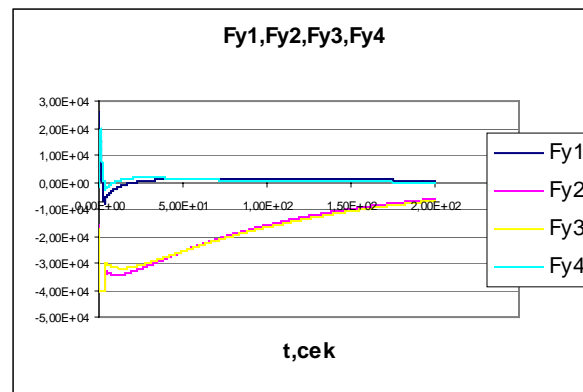

Example7

•Results of simulation of control motion

Initial deviations on linear coordinates - 5 m, on angular - 1 rad.

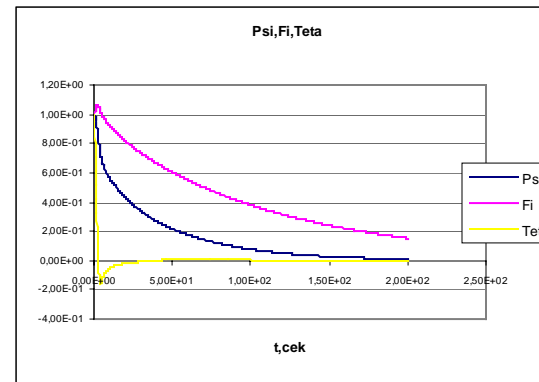
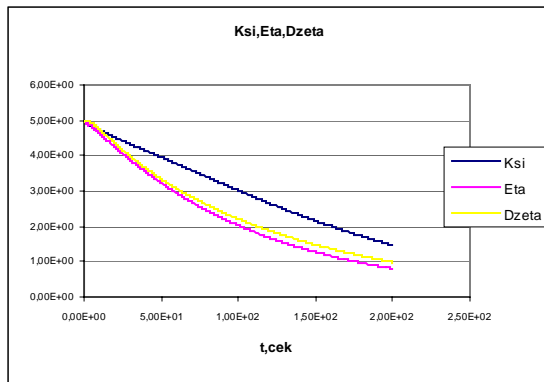

Control system of DP is stable for significant deviations of angular coordinates

Conclusions

- *Main results*

1. The method of construction of regulators ensuring exponential stability of dynamic positioning SMO is offered.
2. The method includes of construction of control laws and observer, which provides exponential stable spatial positioning SMO in the given area of initial deviations (top level of control) and the algorithm of distribution of the received control forces and moments on the thrusters.
3. The simulation has shown high efficiency of the offered approach for DP - tasks

References

1. S.K. Volovodov, M.G.Chernjaev, A.J. Kaverinsky, A.V.Smolnikov, S.S. Volovodov. Distribution of resources of management at spatial stabilization of mobile objects. Gyroscopy and navigation № 1 (40) 2003. page 30-42.
2. S.K. Volovodov, M.G.Chernjaev, A.J. Kaverinsky, A.V.Smolnikov, S.S. Volovodov. Features of the decision of a task of distribution of resources of management at spatial positioning of some sea mobile objects. Gyroscopy and navigation № 1 (48) 2005. page 43-56.
3. S.P.Dmitriev, A.E.Pelevin. Tasks of navigation and management at stabilization of a vessel on a trajectory. GSC Russian Federation CSRI "Electrodevice" SPb.2002.
- 4.S.K.Volovodov, M.G.Chernjaev, A.J.Kaverinsky, S.S.Volovodov, B.P.Lampe. Control principle for dynamic positioning of offshore drilling platforms and ships. 11-th Symposium Maritime Elektrotechnik, Elektronik und Informationstechnik. Rostock University. 2004. p.p.81-86.
5. Fossen, T.I. (1994) *Guidance and Control of Ocean Vehicles*. Wiley. Chichester.1994.
6. T.I. Fossen, A.Groven. Nonlinear Output Feedback Control of Dynamically Positioned Ships Using Vectorial Observer Backstepping. IEEE Transactions of control systems technology, vol.6, No.1,January 1998.