

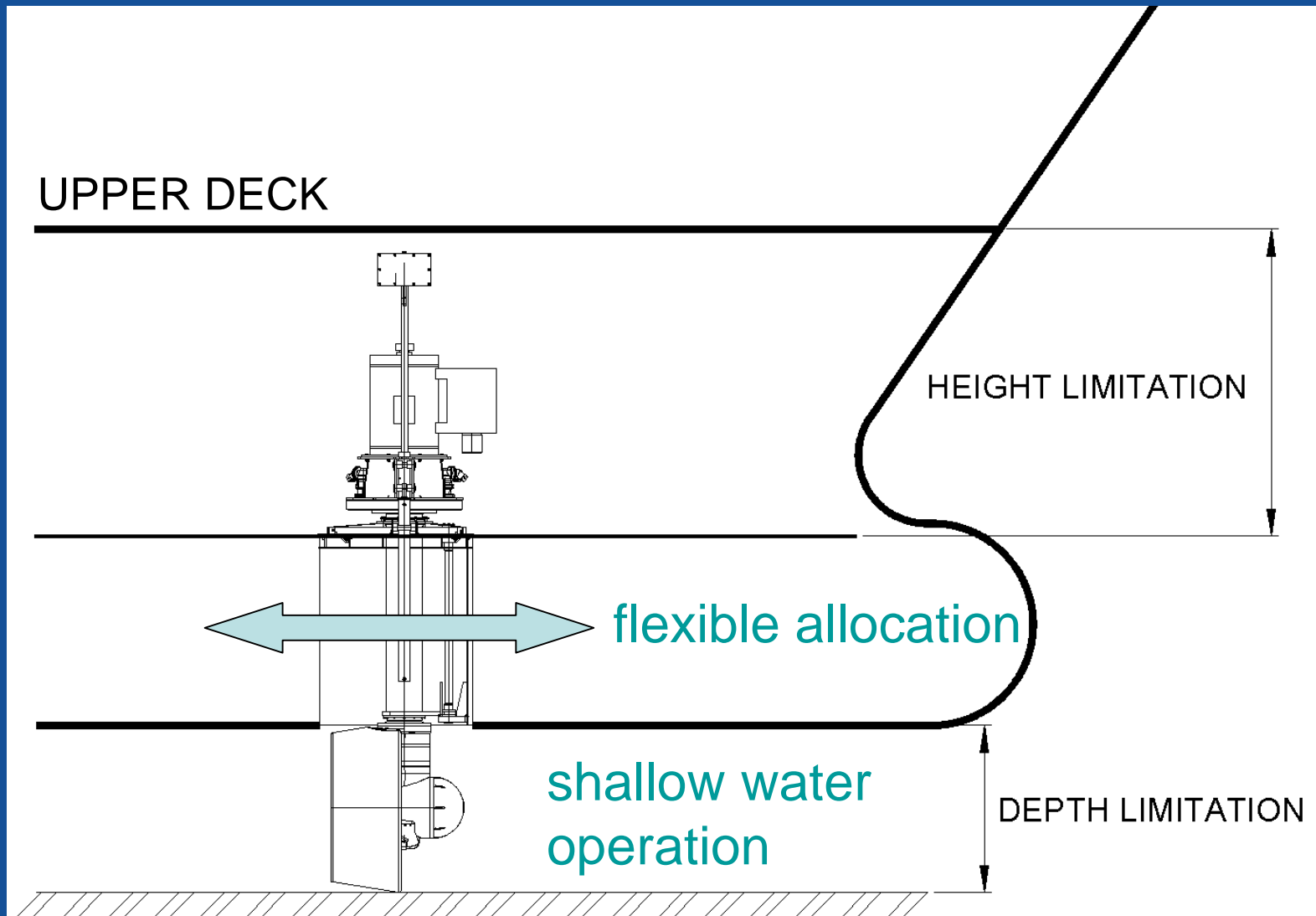

Minimization of Thruster Dimensions for DP Systems

Martijn van Rijsbergen (MARIN)
Henk Terlouw (HRP Thruster Systems)
Cees Leenaars (Dockwise)

Why minimization?



Solution 1

UPPER DECK

Increase number of thruster units

HEIGHT LIMITATION

DEPTH LIMITATION

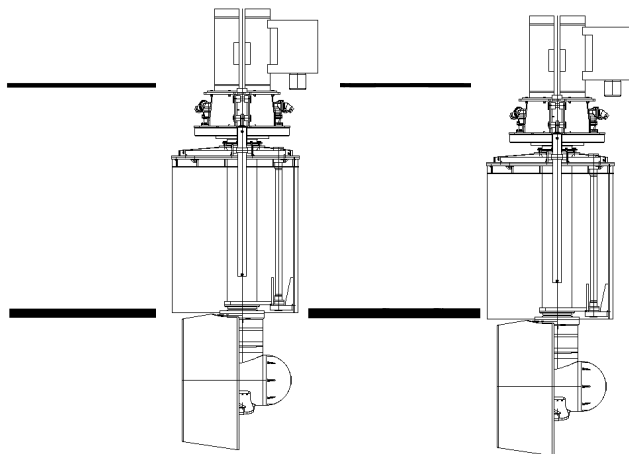

Solution 2

UPPER DECK

Use shallow draft thruster

HEIGHT LIMITATION

DEPTH LIMITATION

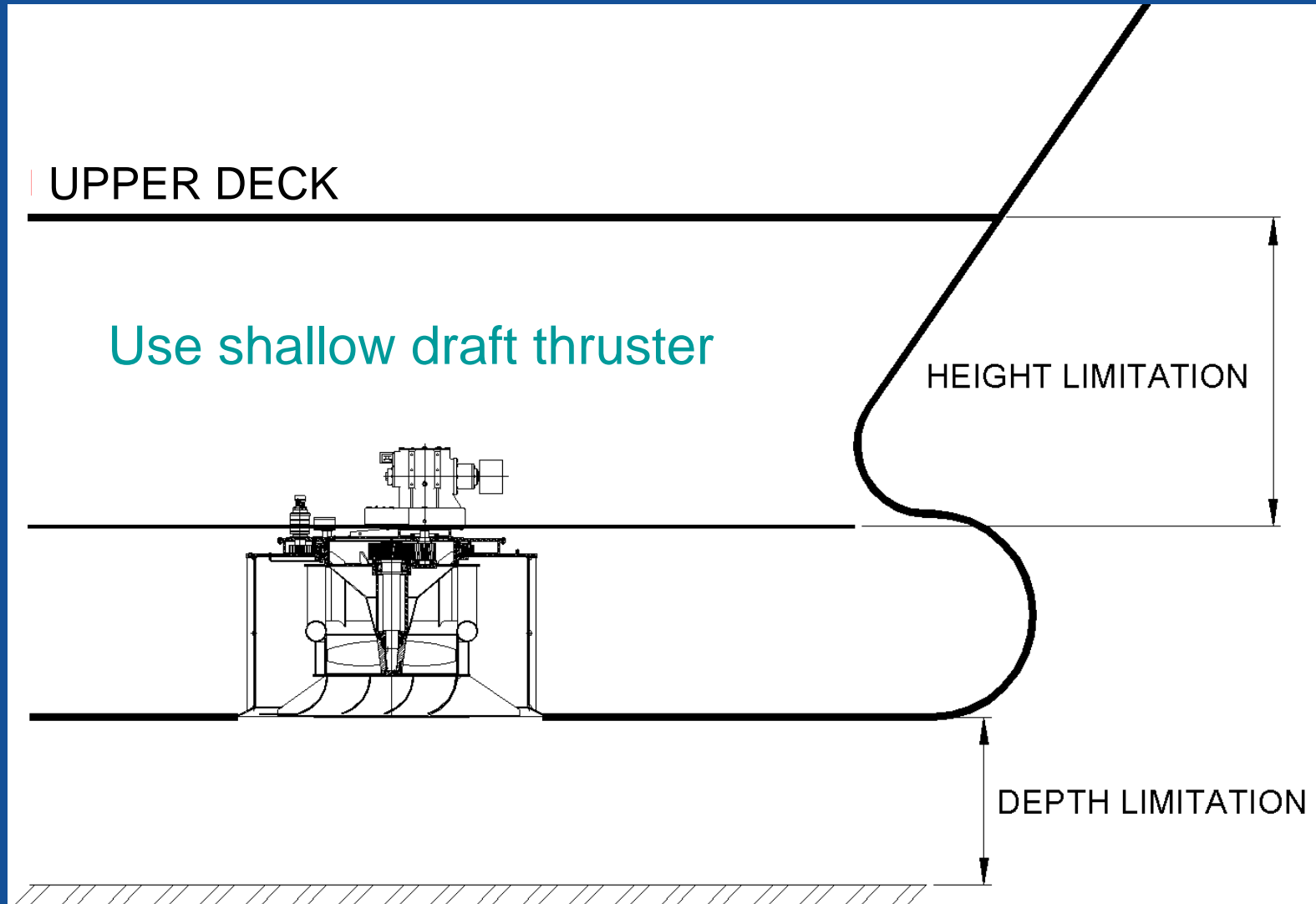

Solution 3

- Decrease propeller diameter
- Increase rotation rate

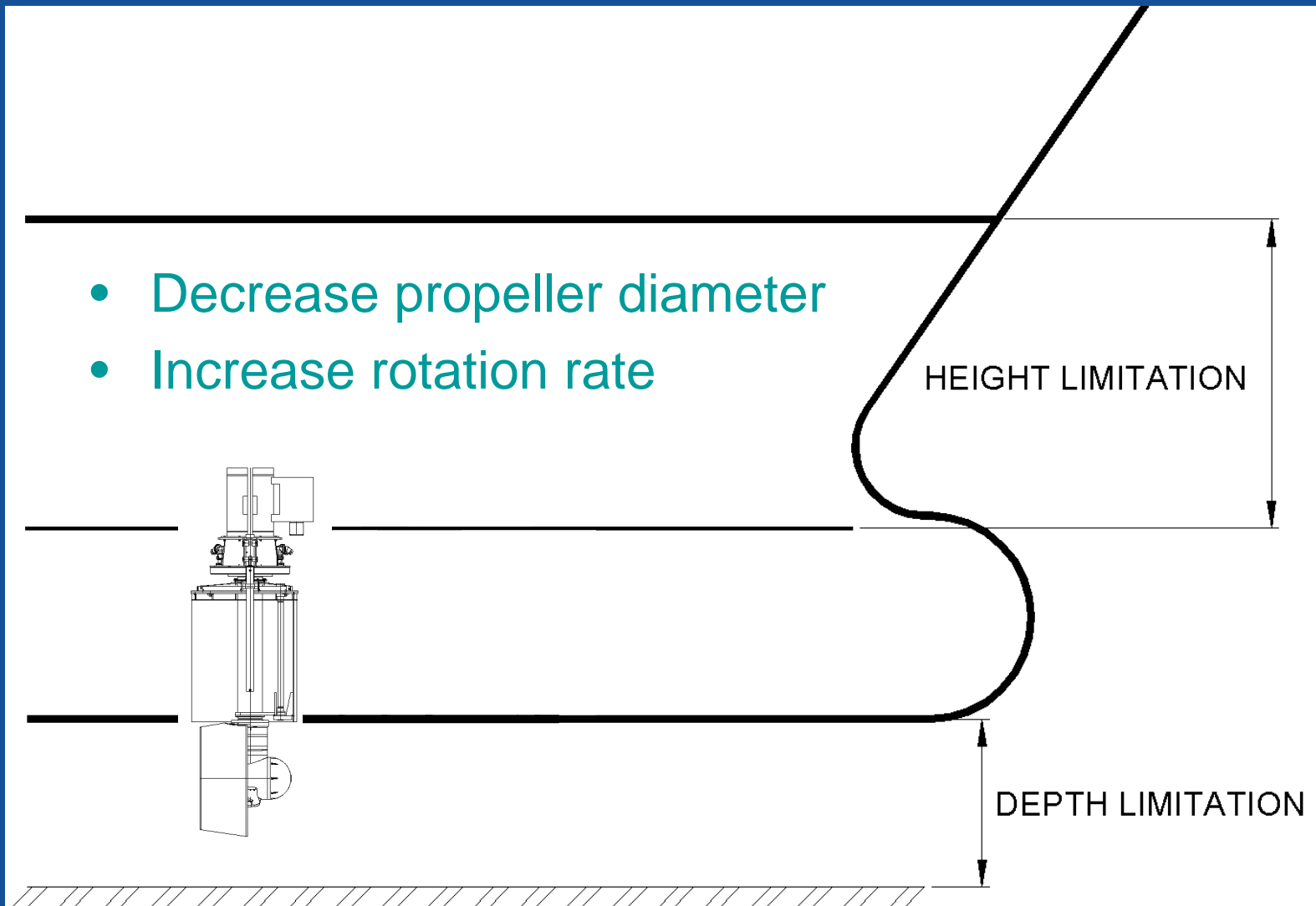

However ...

propeller diameter

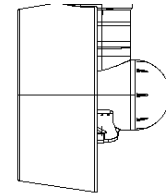
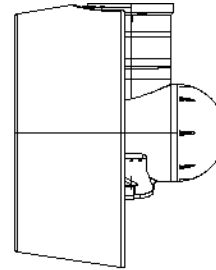
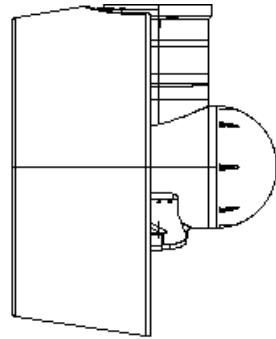

power and cost

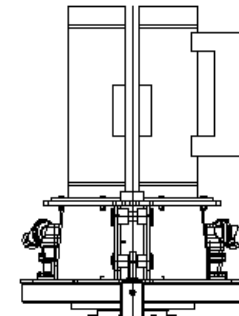
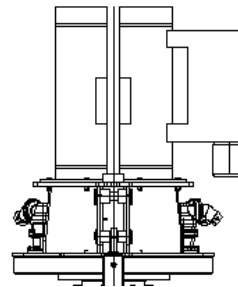
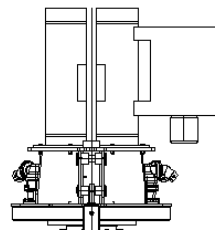

cavitation

→ erosion

→ vibration

→ thrust influence

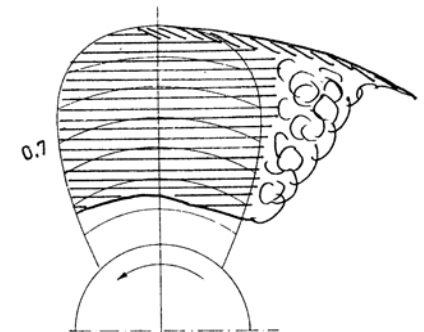
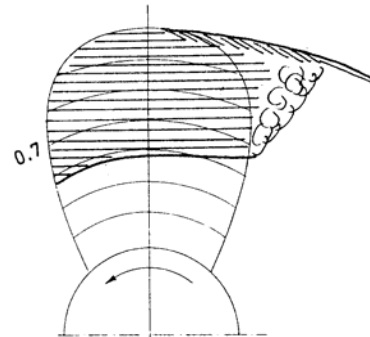
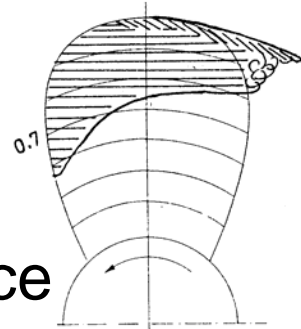

Objective

- What are the limits?
- How small can you make your thruster?
- Rules of thumb: V_{tip} & P/A rather fuzzy

Therefore:

- Investigate by model tests:
 - How propeller design influences cavitation
 - How cavitation influences thrust and power
- Evaluate overall dimensions and costs

Focus on (near) bollard pull condition

Contents

- Maximum thrust density
- Propeller design space
- Thruster design
- Model tests
- Thruster size and cost
- Concluding remarks

Maximum thrust density

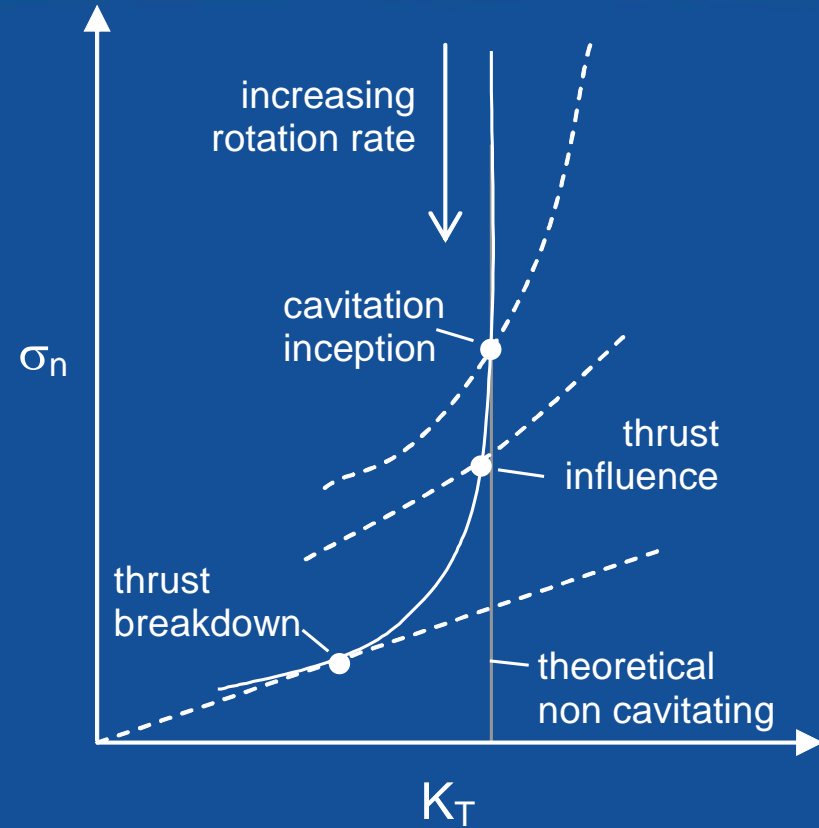
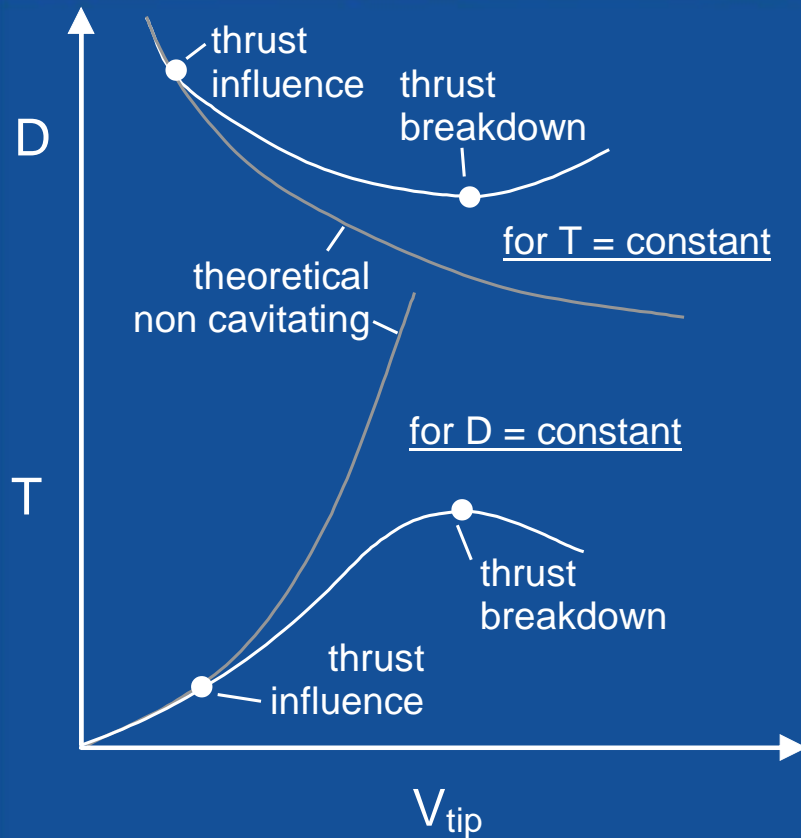

Thrust density:
$$\frac{T}{A_0} = \frac{8 \cdot (P_0 + \rho gh - P_v)}{\pi} \cdot \frac{K_T}{\sigma_n}$$

Preliminary design study

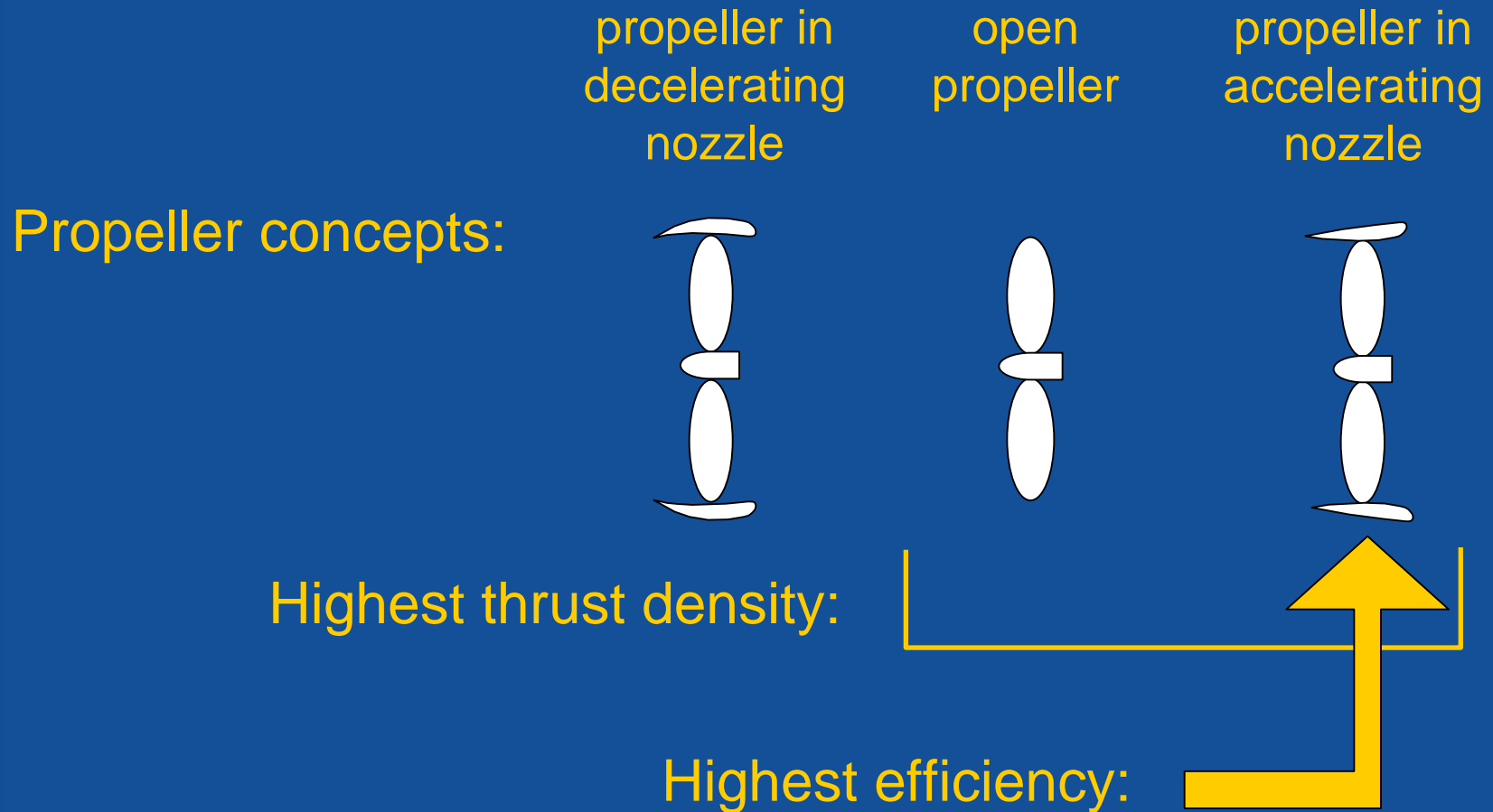

Propeller design space

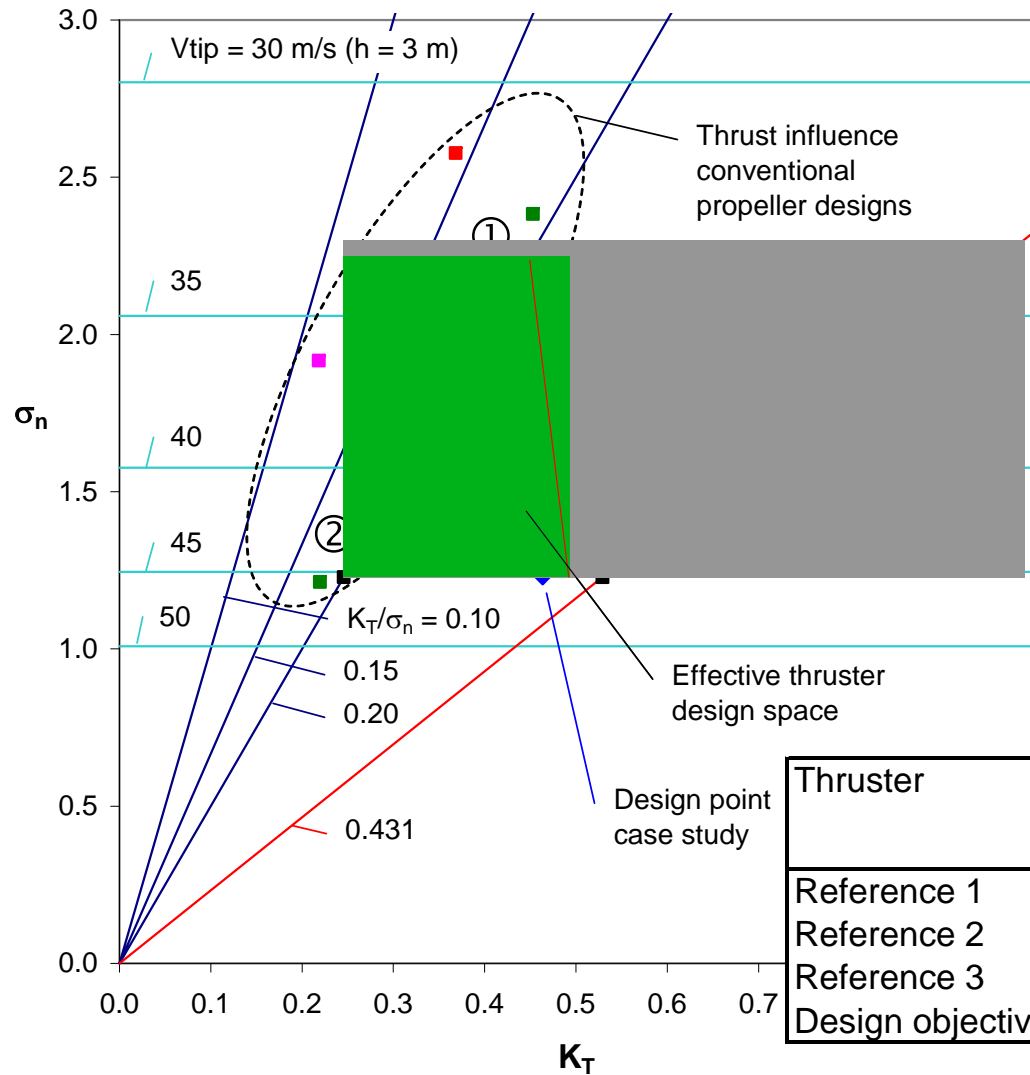

for T = 20 tons:

Thruster	D [m]	P [kW]	Vtip [m/s]	T/P [kg/hp]	T/A [kN/m ²]
Reference 1	1.94	1119	33.5	13.1	67
Reference 2	1.93	1245	45.3	11.8	67
Reference 3	1.32	1642	45.3	9.0	144
Design objective	1.41	1635	45.3	9.0	126

Propeller design space

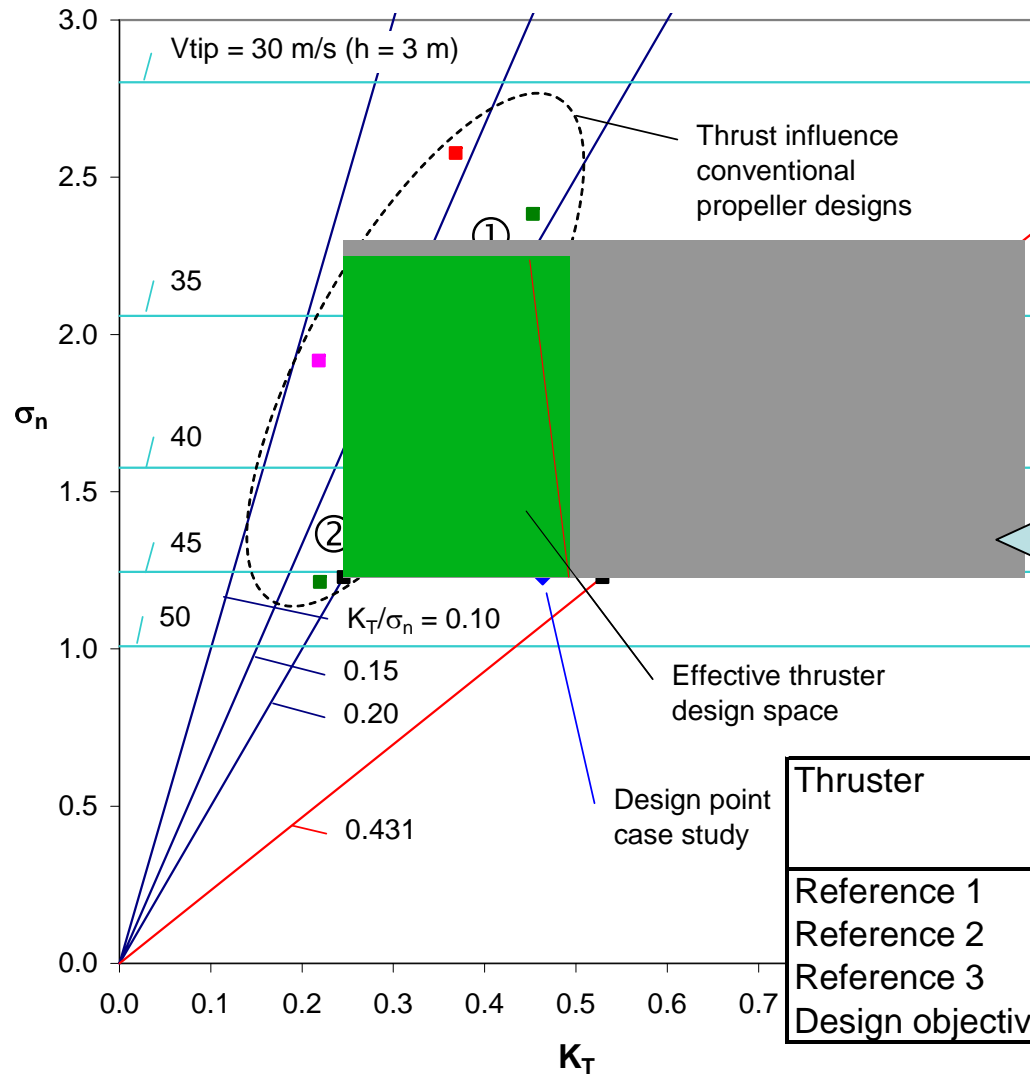

$$D_{\text{gondola}} = f(Q)$$

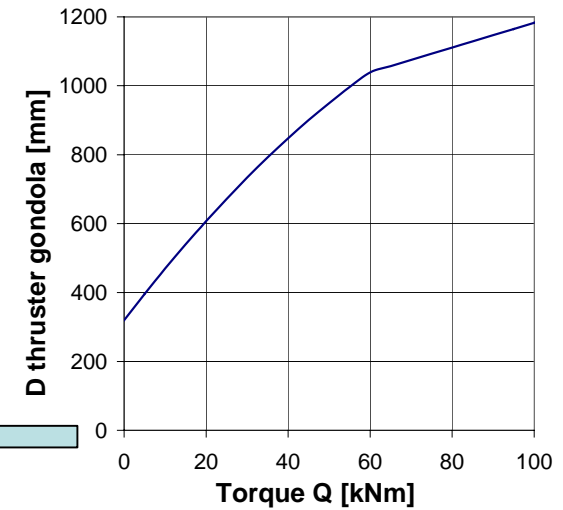

for T = 20 tons:

Thruster	D [m]	P [kW]	Vtip [m/s]	T/P [kg/hp]	T/A [kN/m ²]
Reference 1	1.94	1119	33.5	13.1	67
Reference 2	1.93	1245	45.3	11.8	67
Reference 3	1.32	1642	45.3	9.0	144
Design objective	1.41	1635	45.3	9.0	126

Thruster design

- Pulling propeller for minimum cavitation
- Streamlined housing

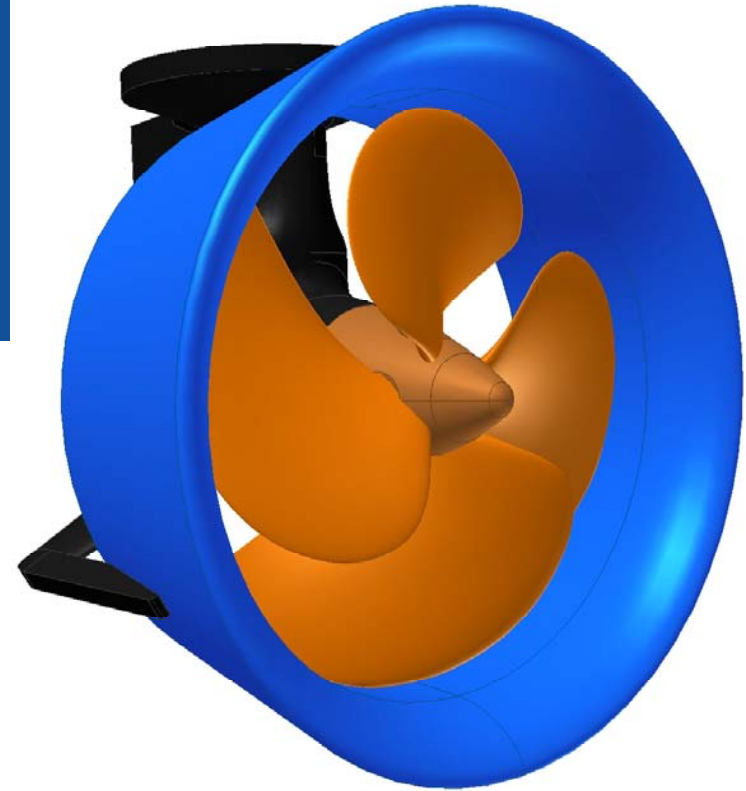
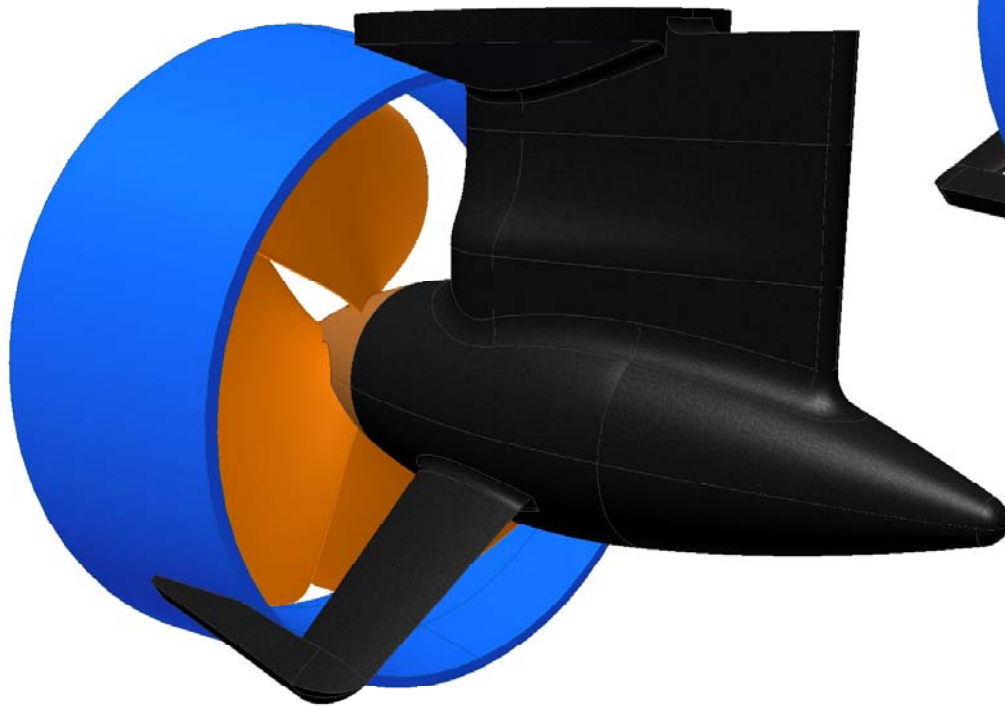

Bollard pull condition

Open water model tests

Bollard pull condition
at 20 tons
(without cavitation):

Thruster	P [kW]	Vtip [m/s]	T/P [kg/hp]
Design objective	1635	45.3	9.0
Model test result	1718	44.3	8.6



Cavitation observations in CT

at $J = 0.12$, $\sigma_n = 1.5$, $V_{tip} = 42$ m/s

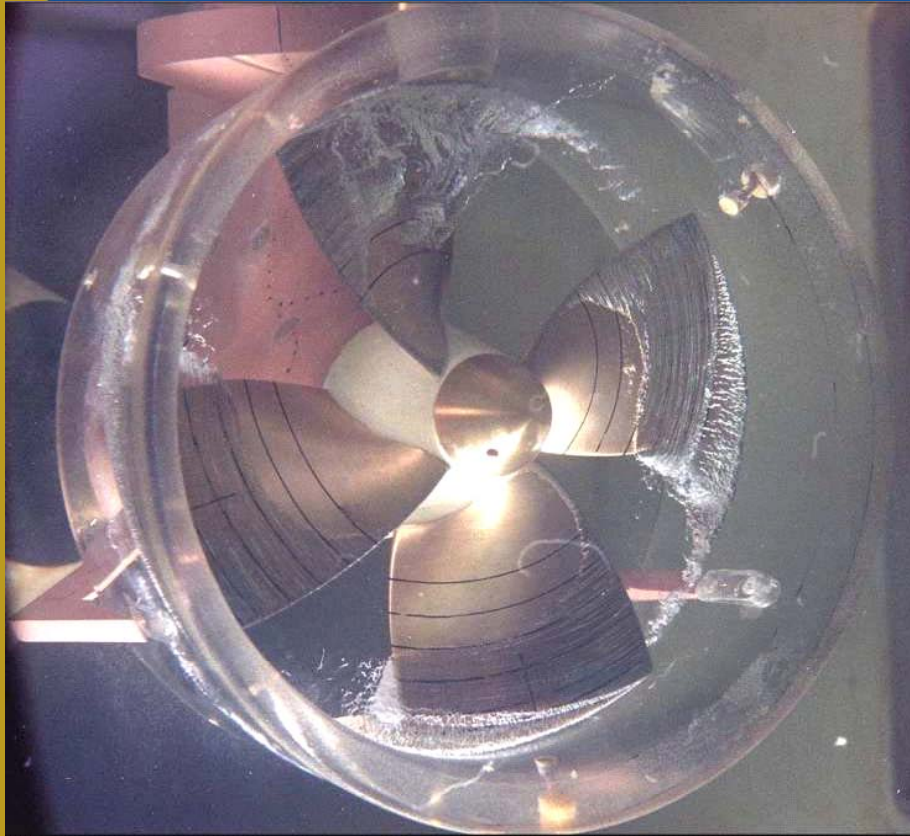

Thruster with Ka 4-70 propeller
at $T = 16.8$ tons

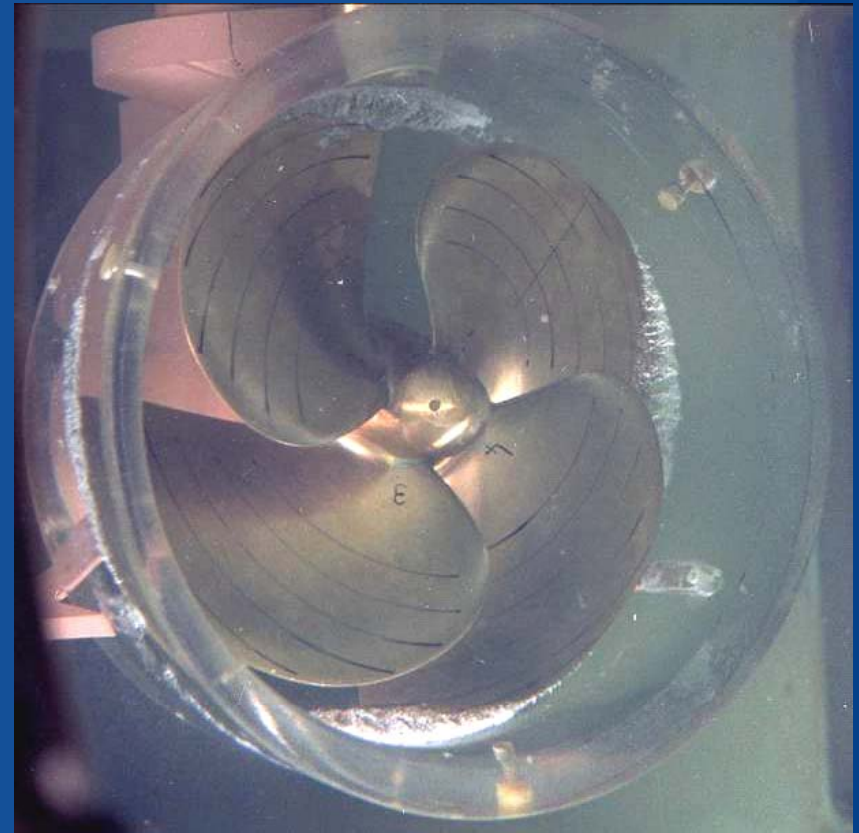

Thruster with design propeller
at $T = 14.8$ tons

Cavitation observations



Thruster with Ka 4-70 propeller
at $T = 18.3$ tons ($V_{tip} = 47$ m/s)



Thruster with design propeller
at $T = 17.5$ tons ($V_{tip} = 46$ m/s)

Cavitation influence

on thrust and torque in bollard pull condition for $D = 1.41$ m

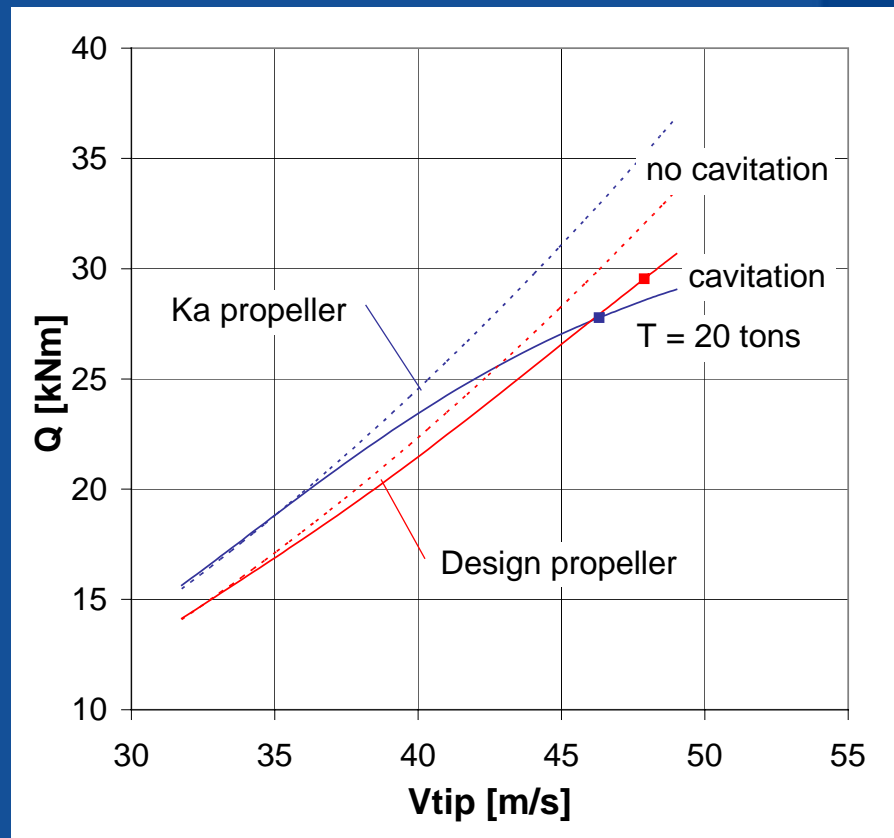
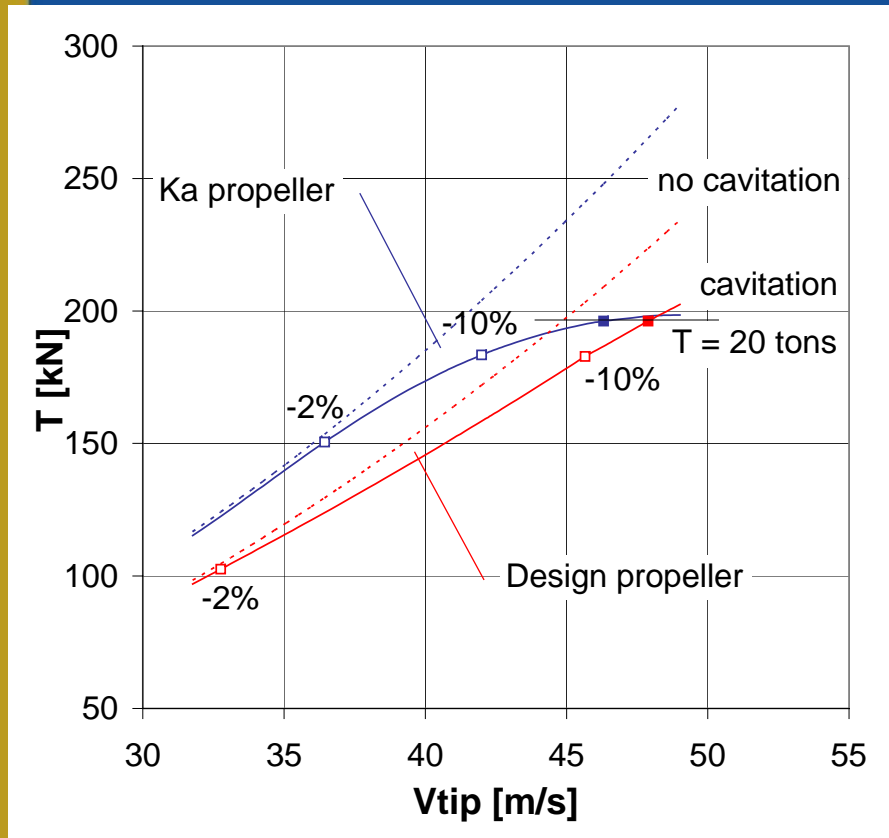

Design propeller is less influenced by cavitation

Comparison in design space

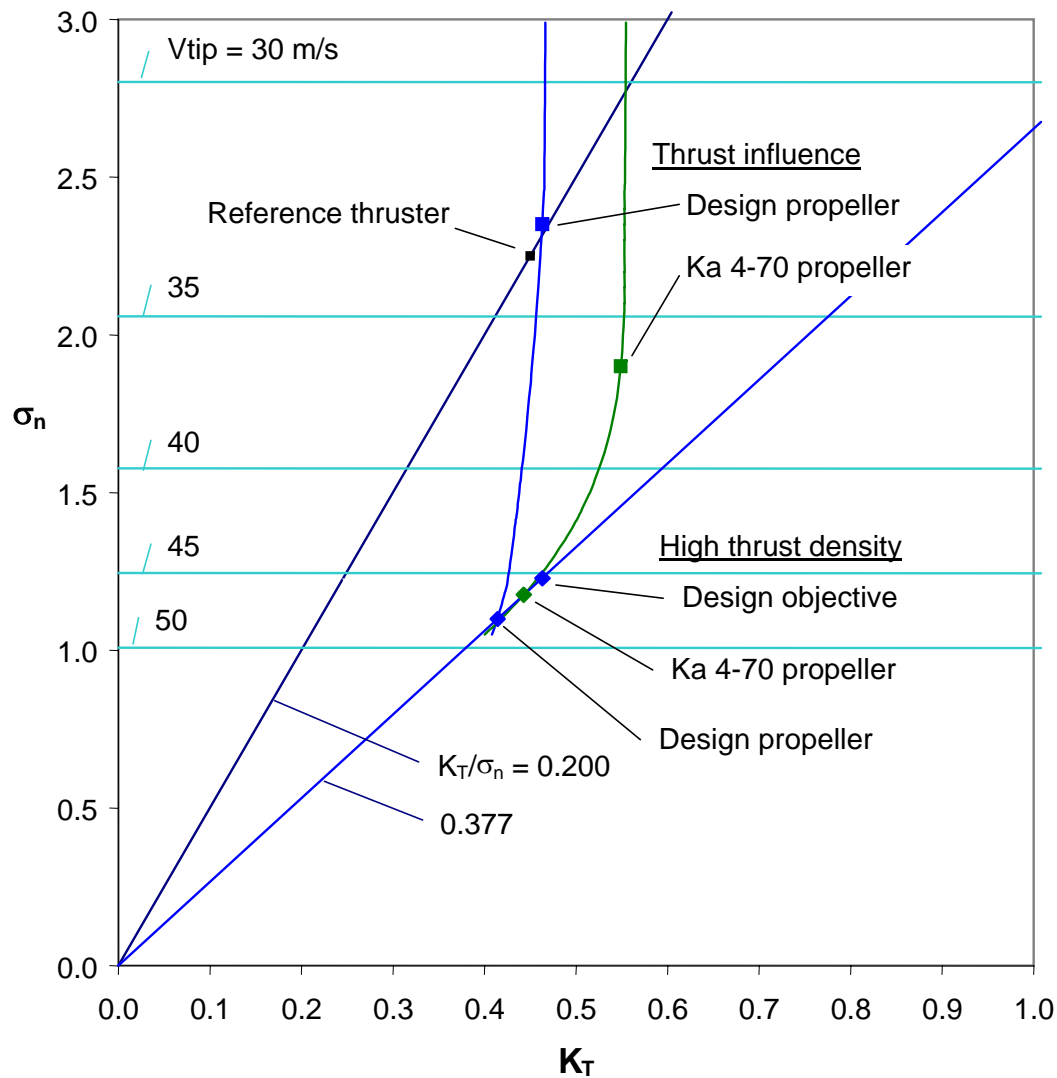

Comparison with reference thruster

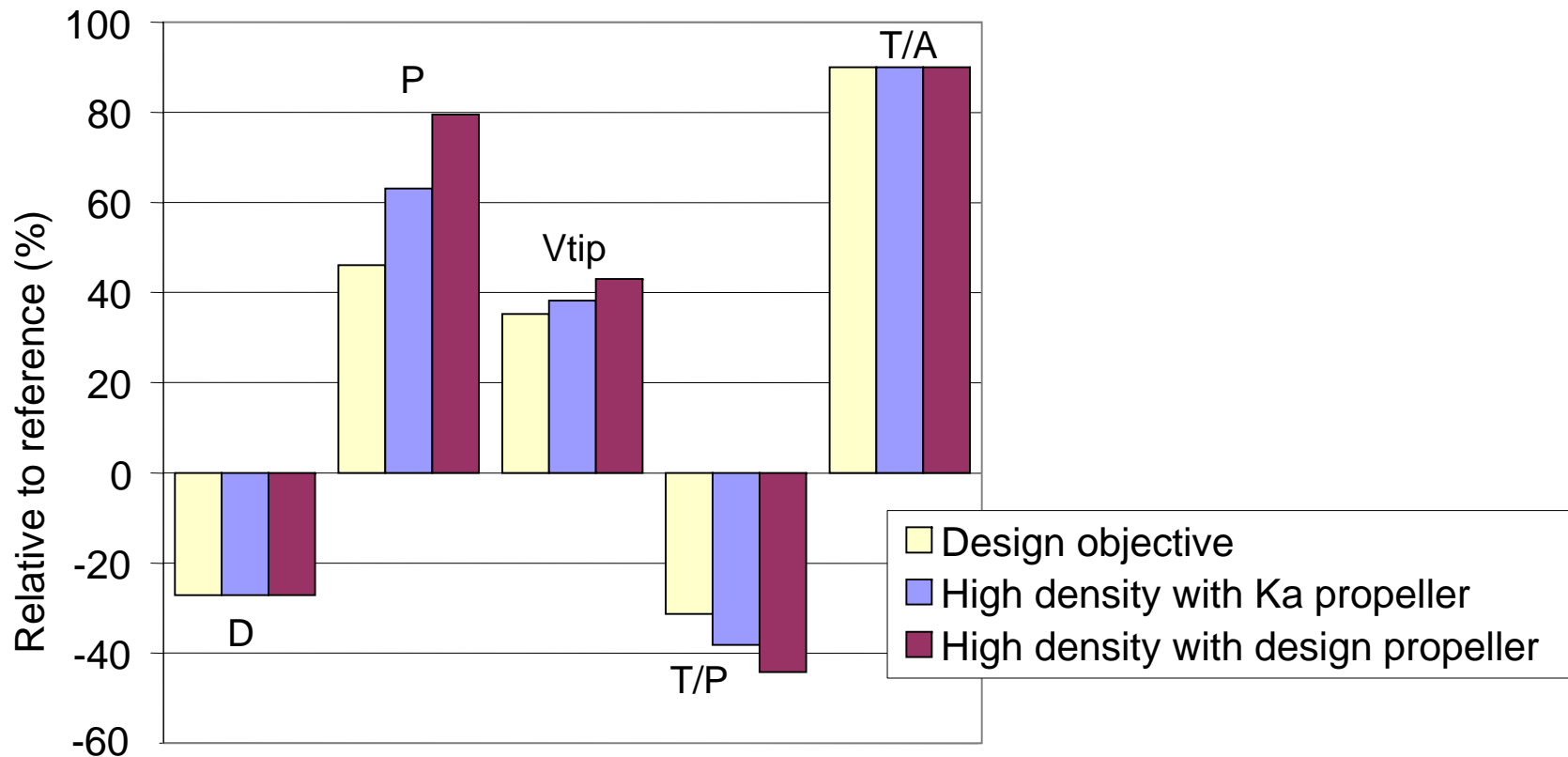

Thruster with T = 20 tons	D [m]	P [kW]	Vtip [m/s]	T/P [kg/hp]	T/A [kN/m ²]
Reference	1.94	1119	33.5	13.1	67
Design objective	1.41	1635	45.3	9.0	126
Model tested with Ka propeller	1.41	1825	46.3	8.1	126
Model tested with design propeller	1.41	2009	47.9	7.3	126

High thrust density

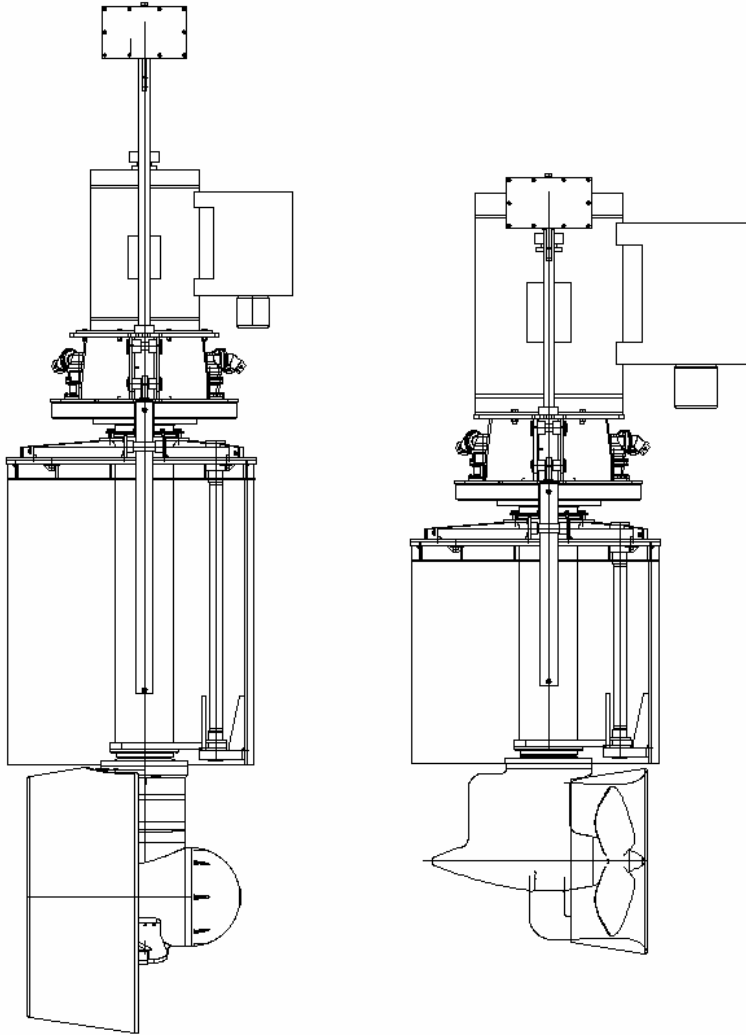

CONVENTIONAL THRUSTER

HD THRUSTER

Size:

- only gain outside hull

Cost:

- acquisition 25% increase
- operational about 50% increase

Medium thrust density

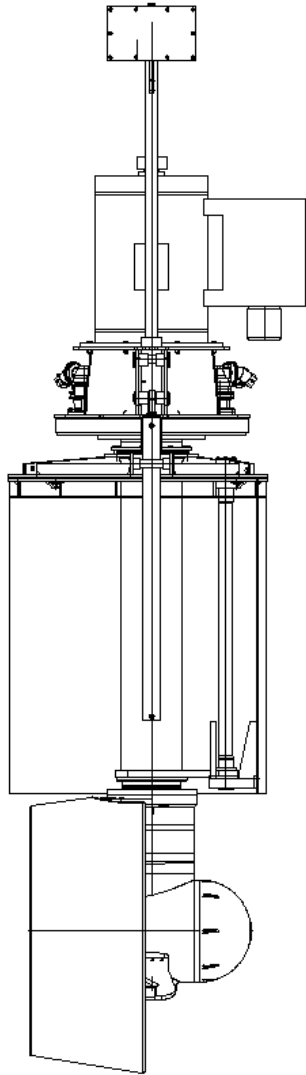

CONVENTIONAL THRUSTER

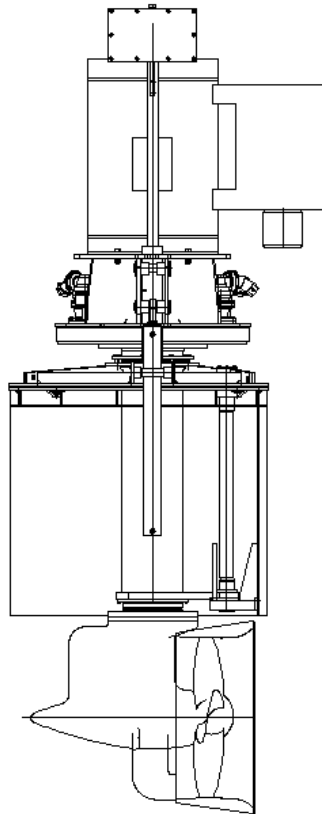

MD THRUSTER

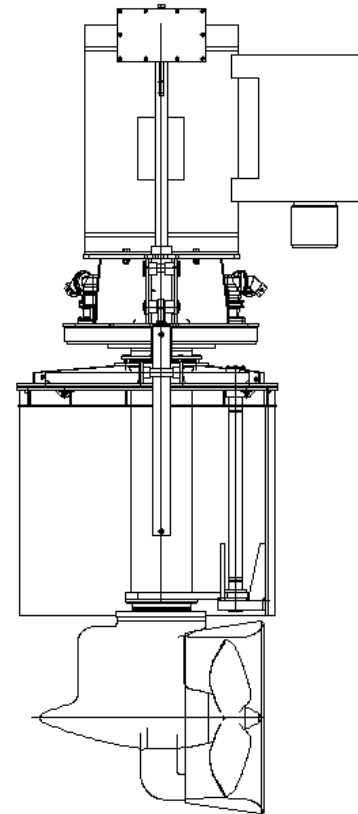

HD THRUSTER

Size:

- gain inside and outside hull

Cost:

- acquisition 8% increase
- operational about 15% increase

Concluding remarks

- Significant reduction in propeller diameter is possible for thruster with pulling propeller. At cost of significant power increase
- Higher power limits decrease of overall dimensions because of size electric drive system
- Moderate reduction of D_{prop} is advised with inboard and outboard gain in dimensions and moderate extra cost
- Propeller designer may accept limited sheet cavitation as compromise between thrust influence and efficiency

Questions

Medium thrust density (2)

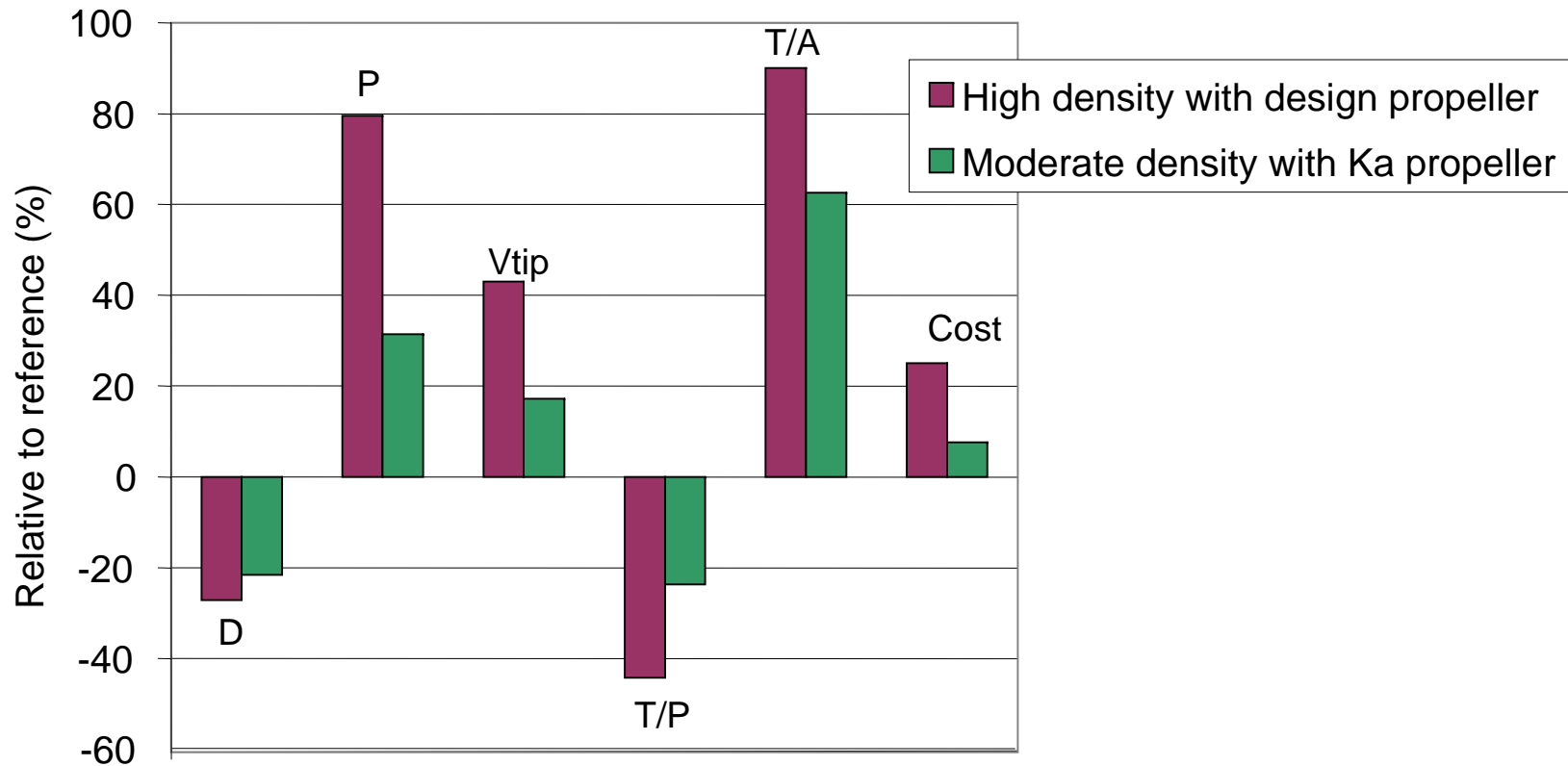

Thruster with T = 20 tons	D [m]	P [kW]	Vtip [m/s]	T/P [kg/hp]	T/A [kN/m ²]
Reference (conventional)	1.94	1119	33.5	13.1	67
MD Thruster with Ka propeller	1.52	1471	39.3	10.0	108
HD Thruster with design propeller	1.41	2009	47.9	7.3	126