



# Development and Application of PTFE Compound Bearings

**Mr. Seiji Yamajo**  
**Kobelco Eagle Marine Engineering Co., Ltd.**

**Mr. Fumitaka Kikkawa**  
**Mikasa Corporation**

**Fig.1 Structure of three-layer bearing**

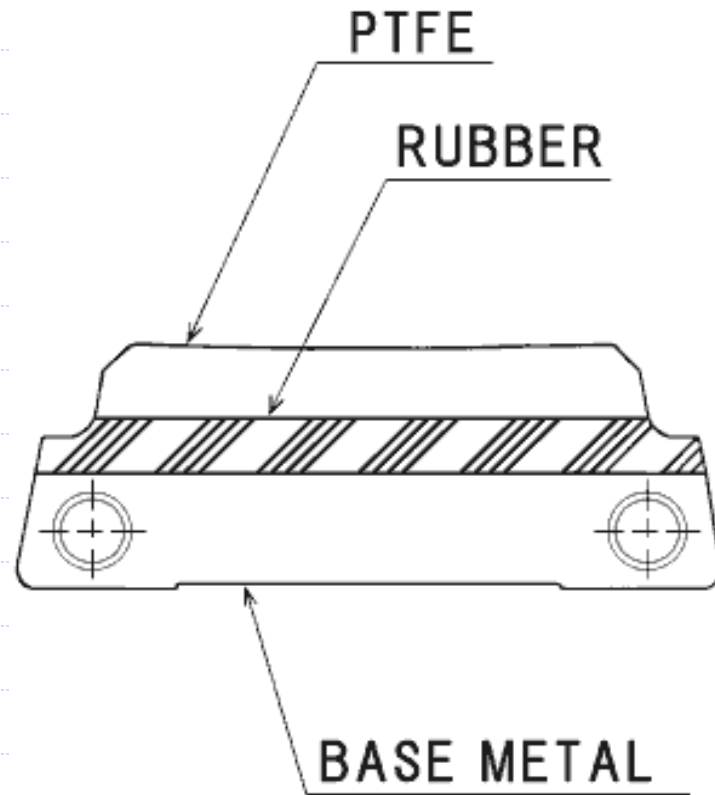

## Table 1 Characteristics of three-layer bearing

Required performance		Rubber	Plastic	Three-layer Bearing
Excellent performance against wear	⇒ Material must be hard.	Soft	Hard	Hard
Flexible against poor alignment	⇒ Material must be flexible to make bearing pressure small.	Flexible	Not-flexible	Flexible

# Fig. 2 Manufacturing equipment of PTFE bearing

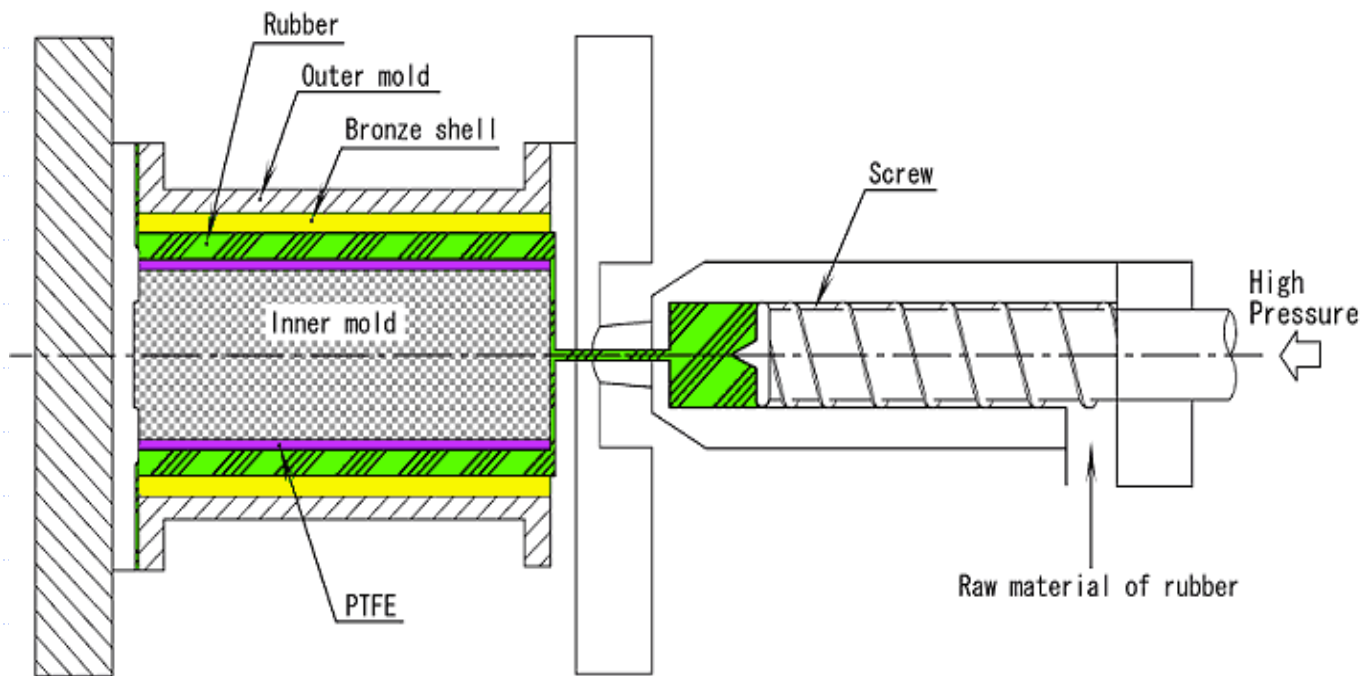

## Fig. 3 Construction of PTFE bearing

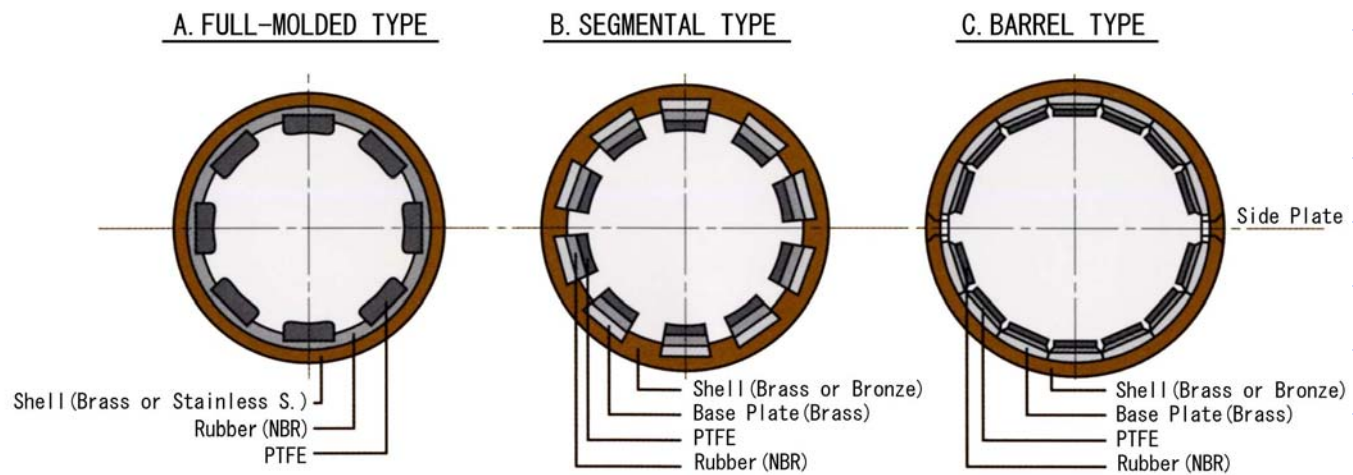

## Table 2 Comparison between rubber bearing and PTFE bearing

Item	Rubber bearing	PTFE bearing
Allowable pressure (Average pressure)	0.25 MPa	0.56 MPa
Max. partial pressure	1.0 MPa	2.5 MPa
Coefficient of friction ( $V > 2.5$ m/s)	0.04	0.01
Operating time in dry condition ( $P = 0.05$ MPa)	0	1 min. 56 sec.
Necessary water supply	3d liter/min. (d cm = shaft dia.)	2d liter/min. (d cm = shaft dia.)

# Fig. 4 Friction characteristics

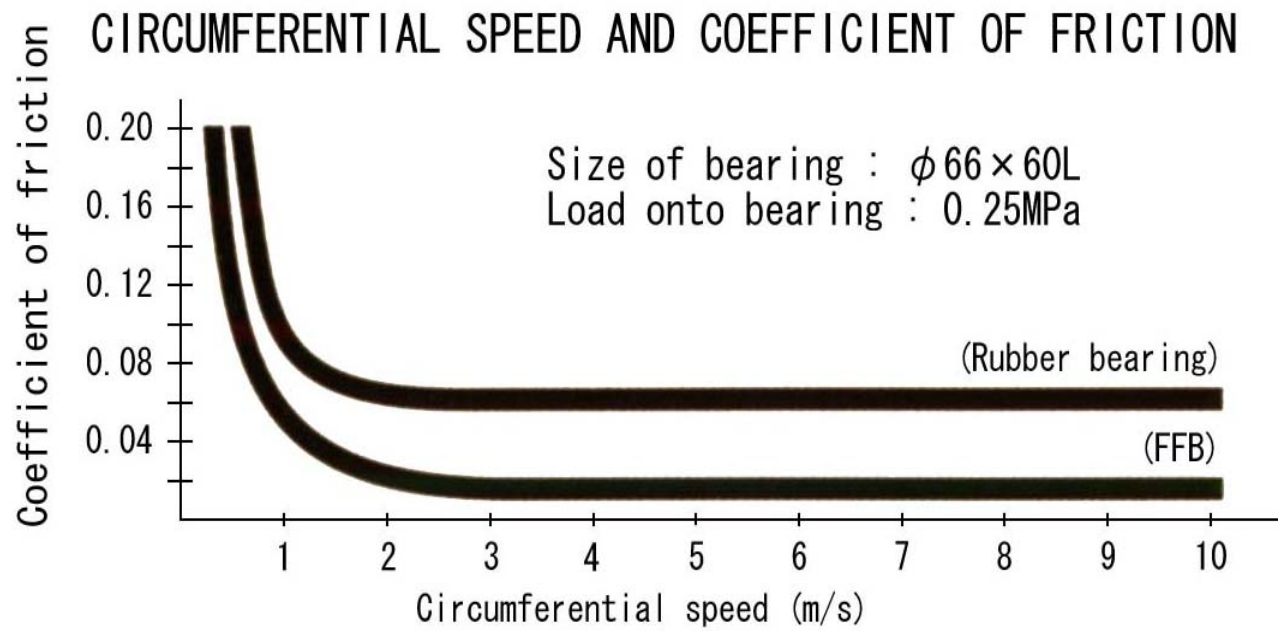

## Table 3 Test condition of friction coefficient test

Item		Condition
Shaft Sleeve	Material	70-30 Copper-Nickel
	Diameter	140 mm (5½ inches)
Bearing	Material	PTFE Compound Bearing
	Diameter	140 +0.5 mm +0.6
	Length	140mm
Shaft Revolution		6~490 r.p.m. (0.04~3.5 m/s)

Fig. 5 Dynamic and static friction coefficients

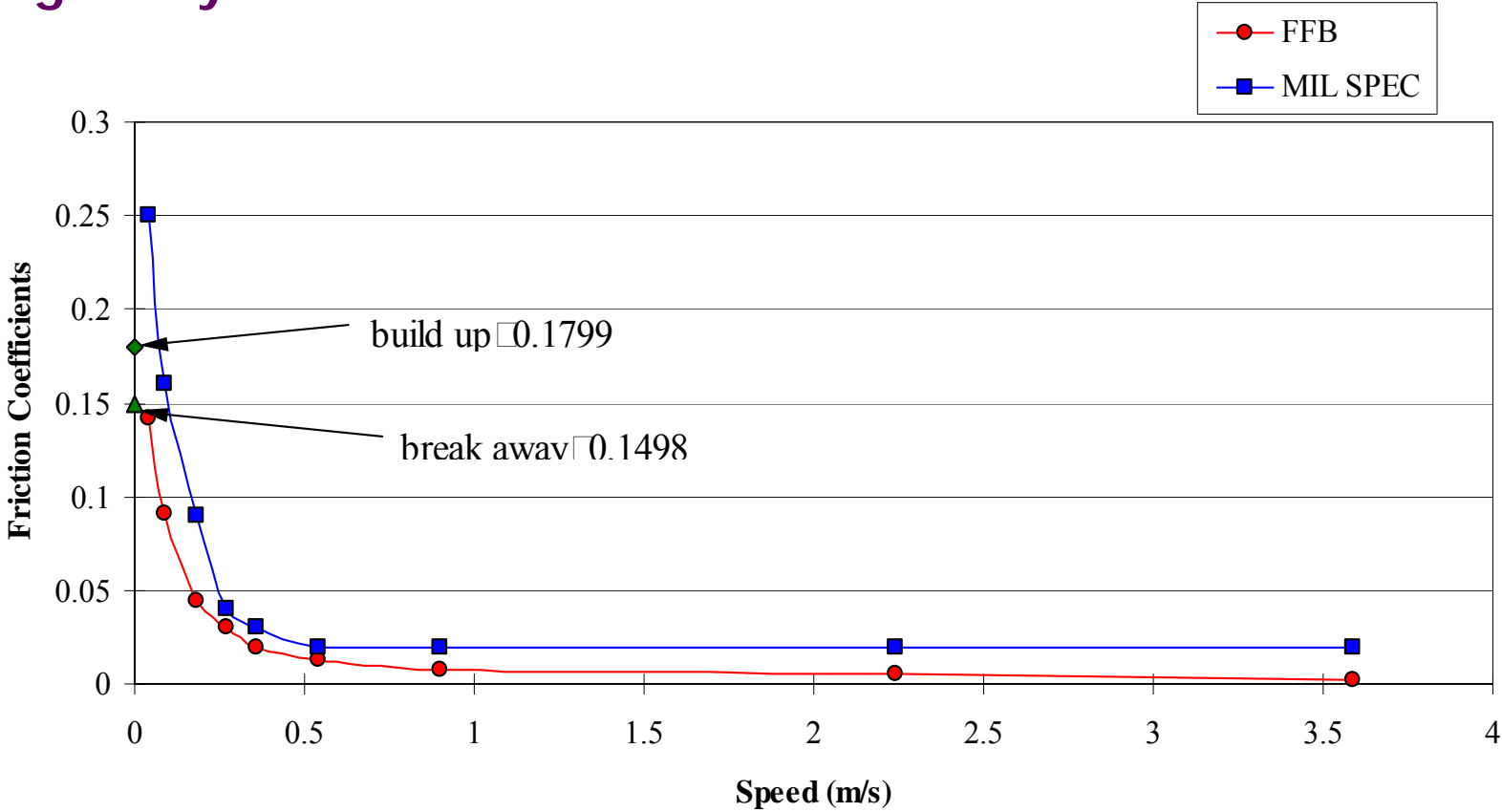

## Table 4 Heat resistance

MATERIAL	HEAT RESISTANCE (DRY)	HYDROLYSIS IN WATER	MELTING POINT
PTFE	260°C	.	324°C
URETHANE	100°C	AROUND 60°C OR MORE	263°C

# Fig. 6 Swelling in seawater

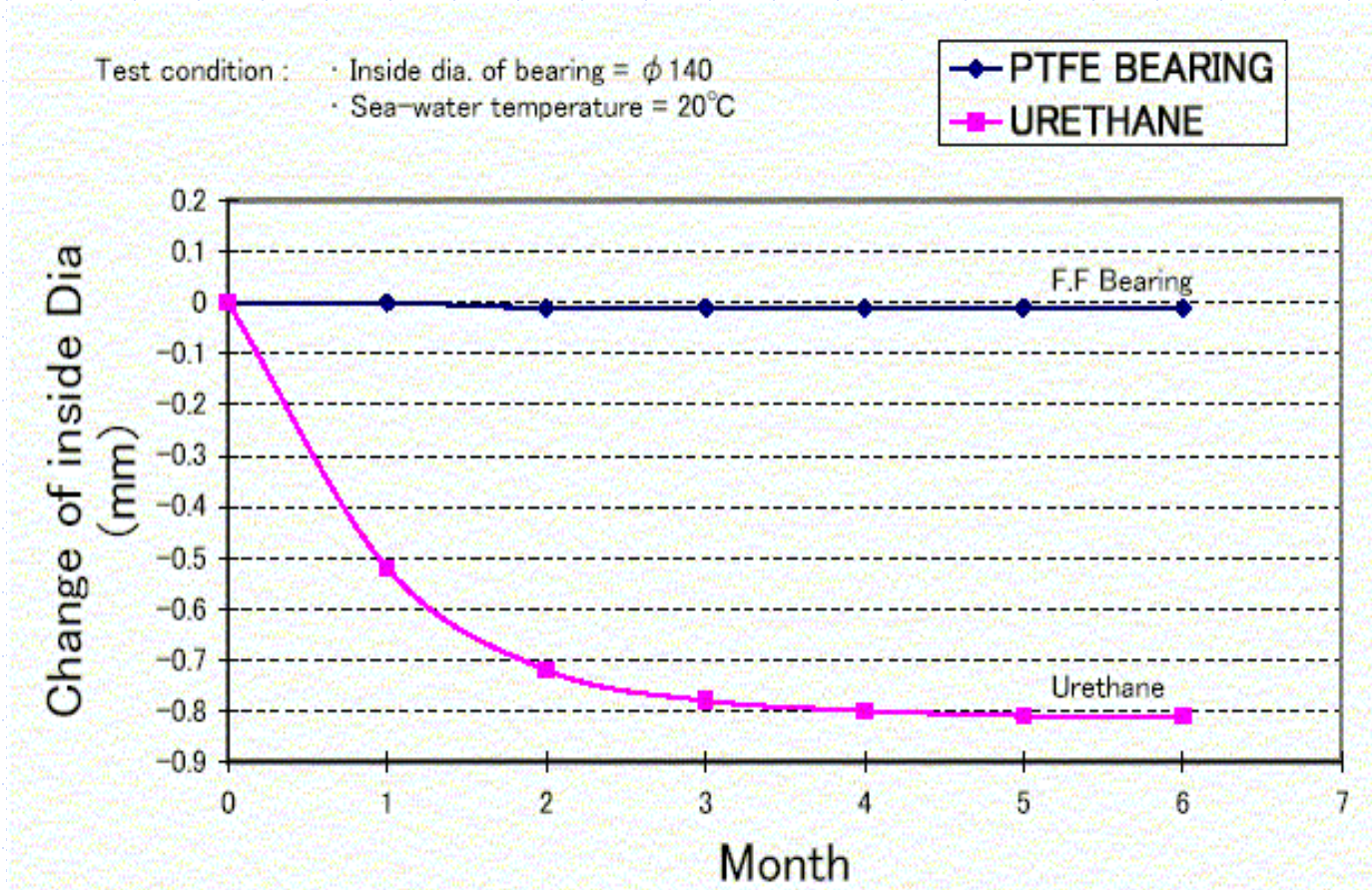

**Table 5 Young's modulus of bearing**

KIND OF BEARING	YOUNG'S MODULUS
PTFE BEARING	50 MPa
RUBBER BEARING	10 MPa
URETHANE BEARING	1500 MPa

**Fig. 7 Bearing pressure on bracket bearing**

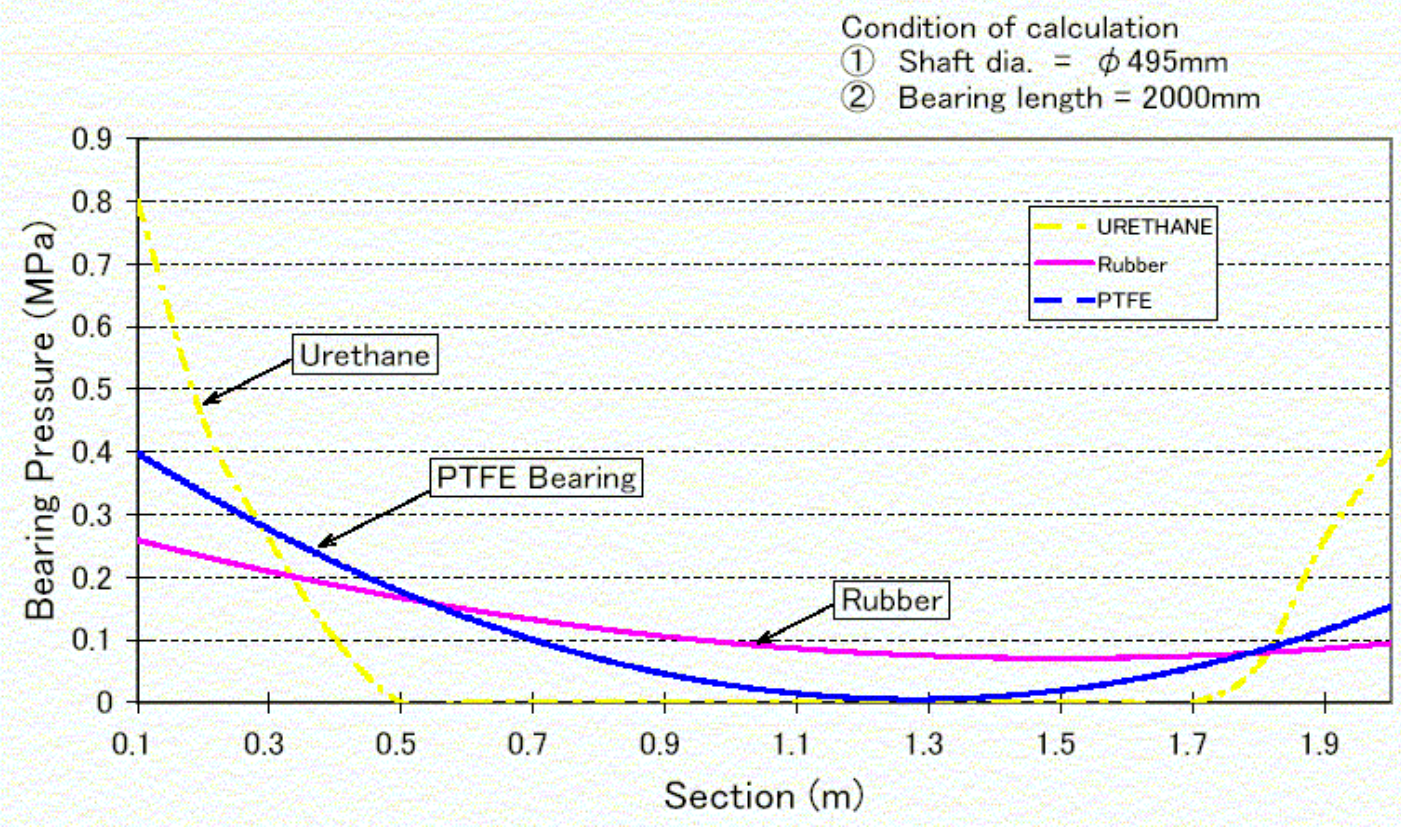

**Fig. 8 Durability in dry condition**

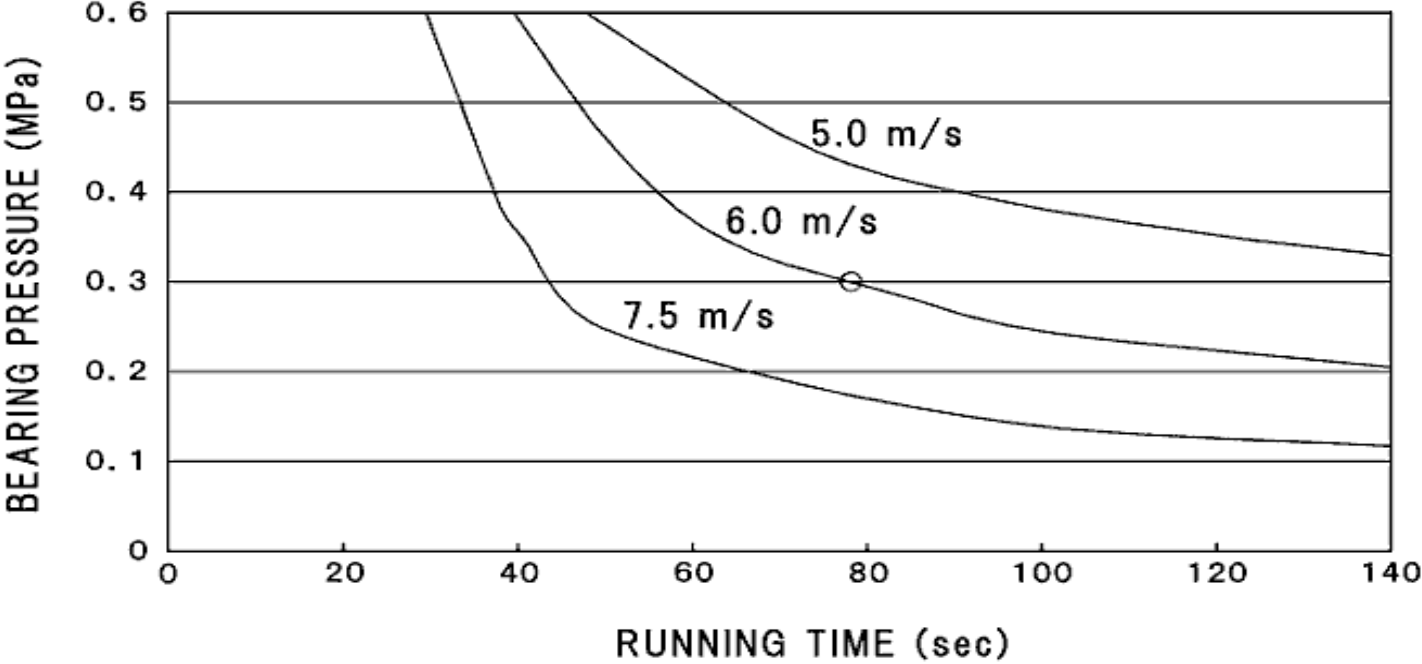

# Fig. 9 No water supply test equipment

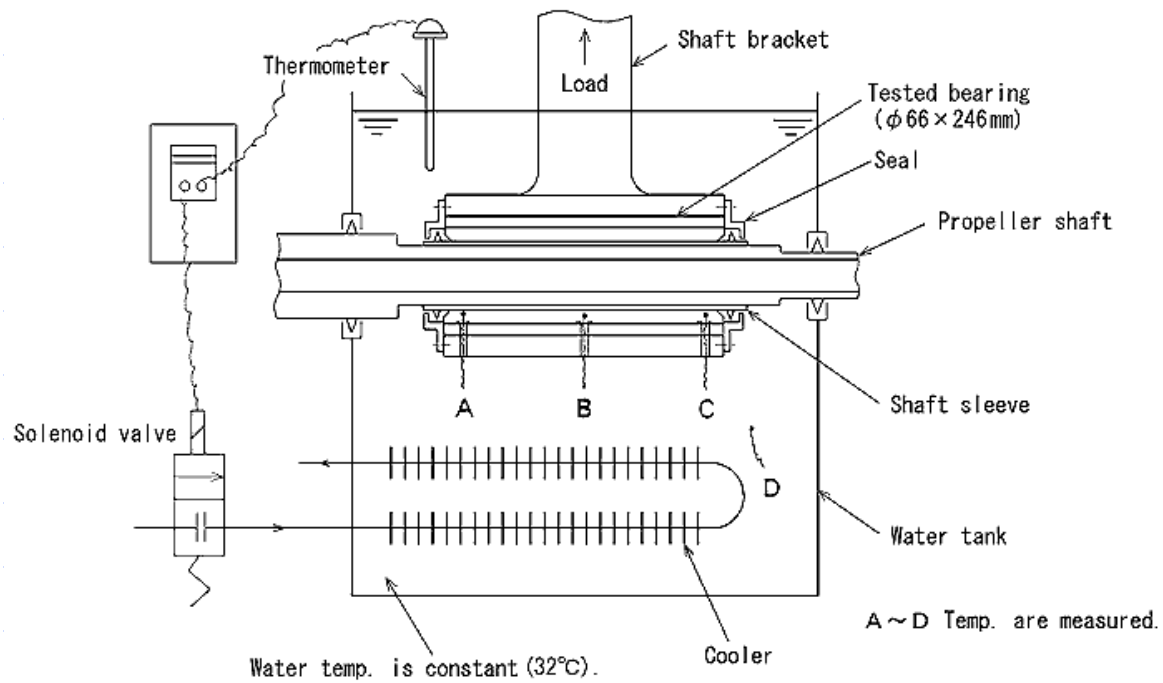

# Fig. 10 Temperature of bearing

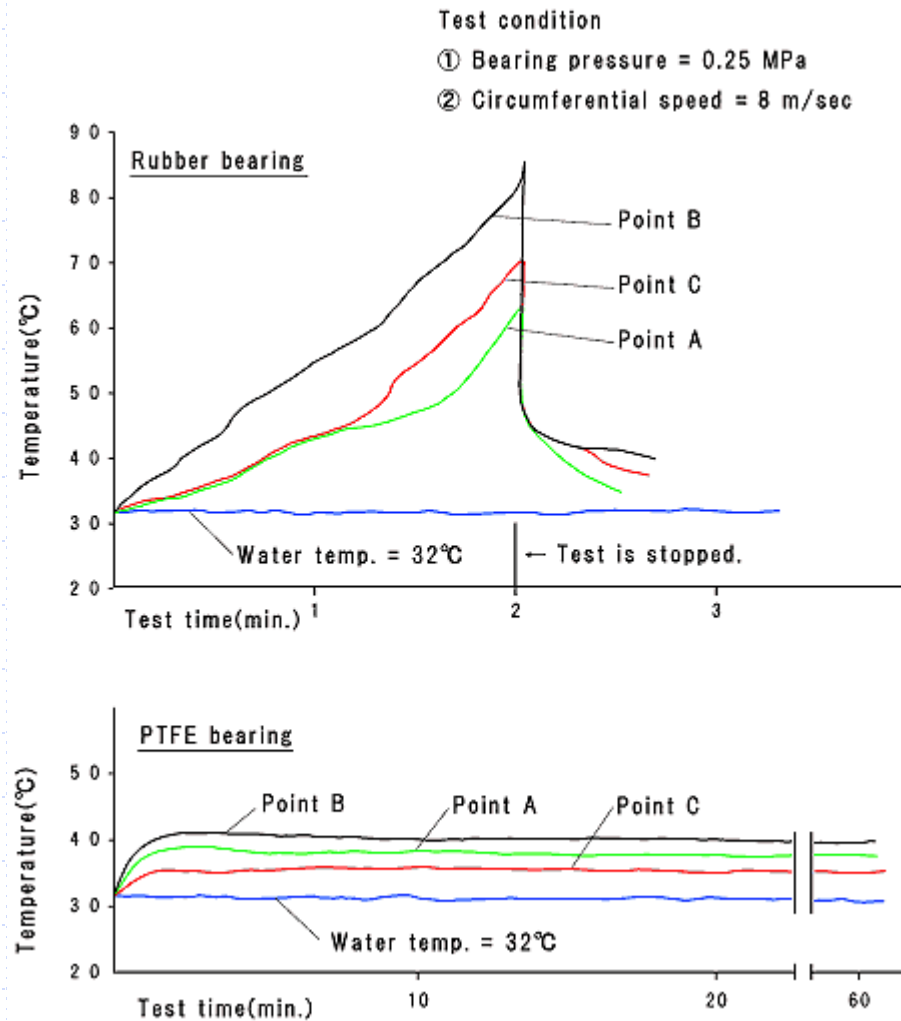

**Fig. 11 Abrasion test equipment (Shaft dia. – 200mm)**

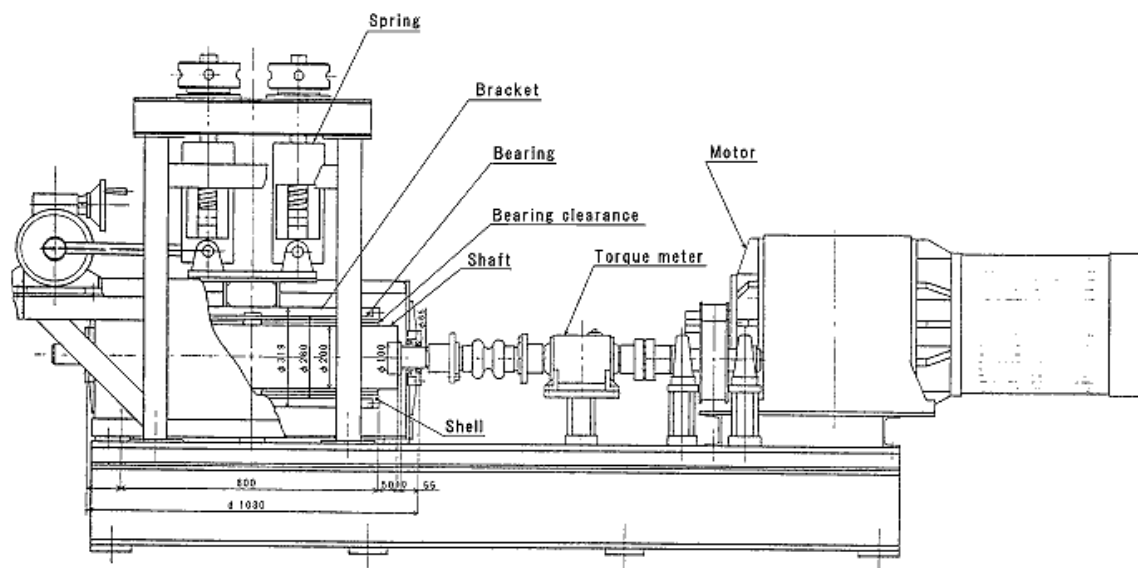

**Fig. 12 Water supply line of test equipment**

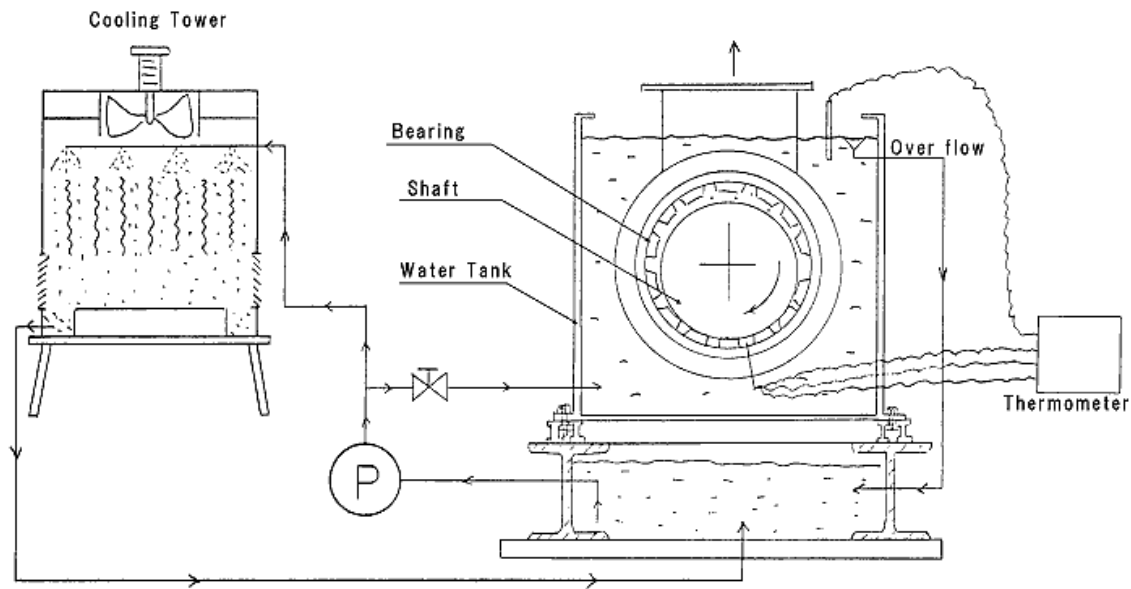

## Table 6 Test condition (1)

Item		Condition
Shaft sleeve	Material	BC2 + 0.5% Ni
Bearing	Type	Barrel Type
	Size	$\phi 200 \text{ mm} \times 400 \text{ mm}$
	Clearance	0.7 ~ 0.8 mm
Test condition	Average pressure	1 MPa
	Revolution	600 r.p.m. ( $v=6.28 \text{ m/s}$ )
	Volume of sand	0.3 % (weight % in water)
	Water temperature	20°C ~ 25°C
	Test hours	1000 Hr

Fig. 13 Wear after 1000 hours

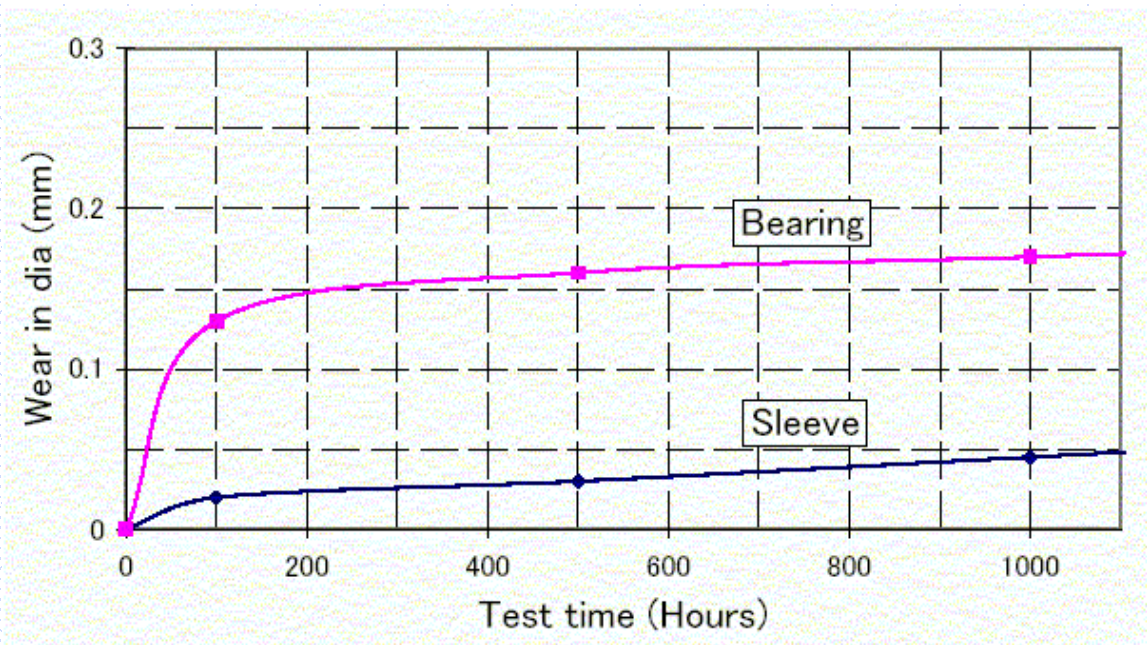

**Fig. 14 Abrasion test equipment (Shaft dia. = 300mm)**

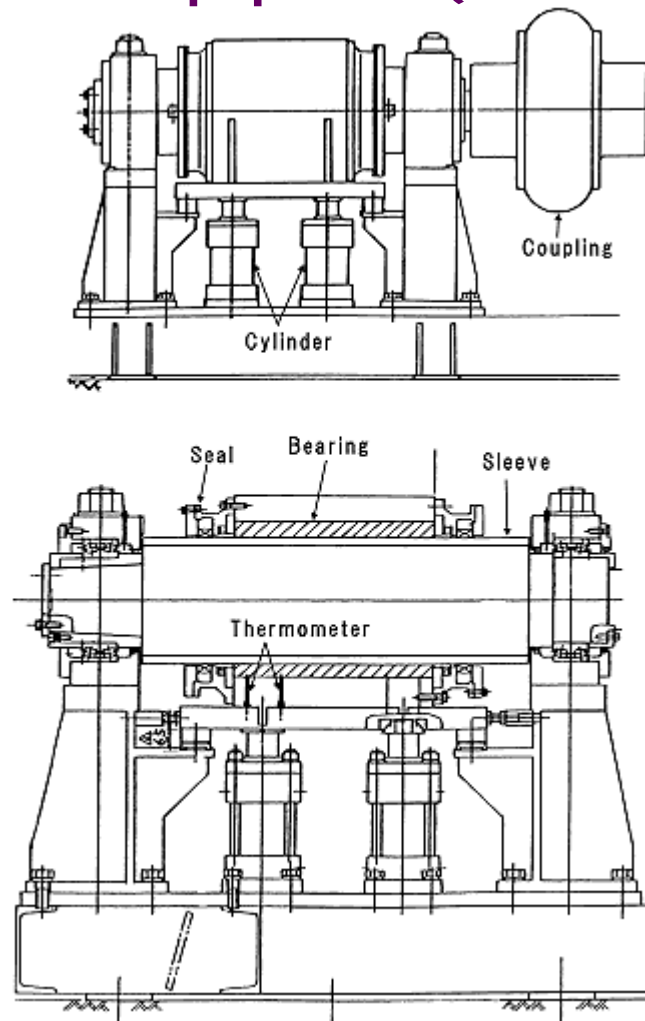

## Table 7 Test condition (2)

Item		Condition
Bearing	Type	Full mold type
	Dimension	L=450mm, Do=φ380mm, Di=φ300mm
Sleeve	Material	BC2 + 0.5% Ni
	Dimension	L=650mm, Do=φ300mm, Di=φ260mm
Bearing Clearance		1.0 mm
Supplied water	Kind	Pure water without sand
	Quantity	2000 liter/hr
	Temperature	24°C~ 27°C
Test condition	Revolution	60 r.p.m.(1m/s)
	Test period	4 months

## Table 8 Load condition

Load	Average bearing pressure	AFT : <u>Center</u> : FWD	Tested period
A	0.5 MPa	$P_{\text{AFT}}=0.7\text{MPa}$ , $P_{\text{CENTER}}=0.5\text{MPa}$ , $P_{\text{FWD}}=0.3\text{MPa}$	1 month
B	1.0 MPa	$P_{\text{AFT}}=1.4\text{MPa}$ , $P_{\text{CENTER}}=1.0\text{MPa}$ , $P_{\text{FWD}}=0.6\text{MPa}$	2 month
C	1.5 MPa	$P_{\text{AFT}}=2.1\text{MPa}$ , $P_{\text{CENTER}}=1.5\text{MPa}$ , $P_{\text{FWD}}=0.9\text{MPa}$	1 month

Fig. 15 Wear test for four months

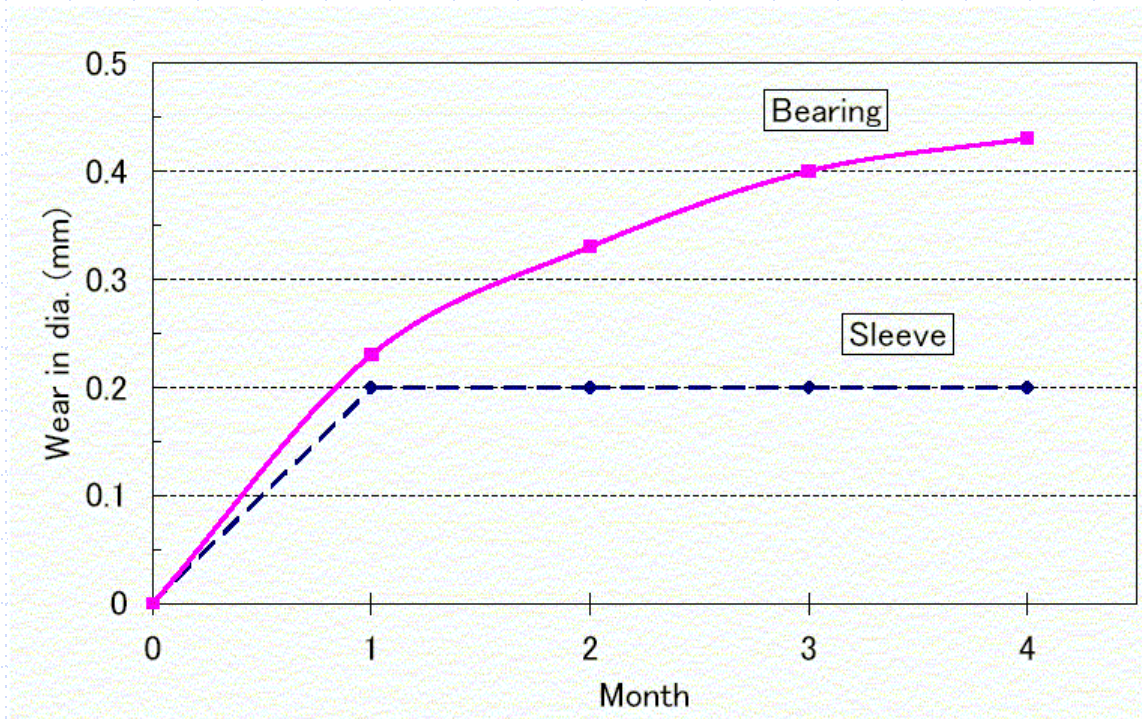

**Table 9 ABS Design Assessment**

<b>Item</b>		<b>Condition</b>
Lubrication		Water Lubricated Stern Tube Bearing
Shaft Diameter (D)		40mm (1.6 inch) ~ 1,000mm (40 inch)
Bearing Length (L)		$L \geq 2 \times D$
Load on Bearing	Average Pressure	Less than 6 kgf/cm <sup>2</sup>
	Max. Local Pressure	Less than 20 kgf/cm <sup>2</sup>

# Fig. 16 Change of clearance on a Destroyer

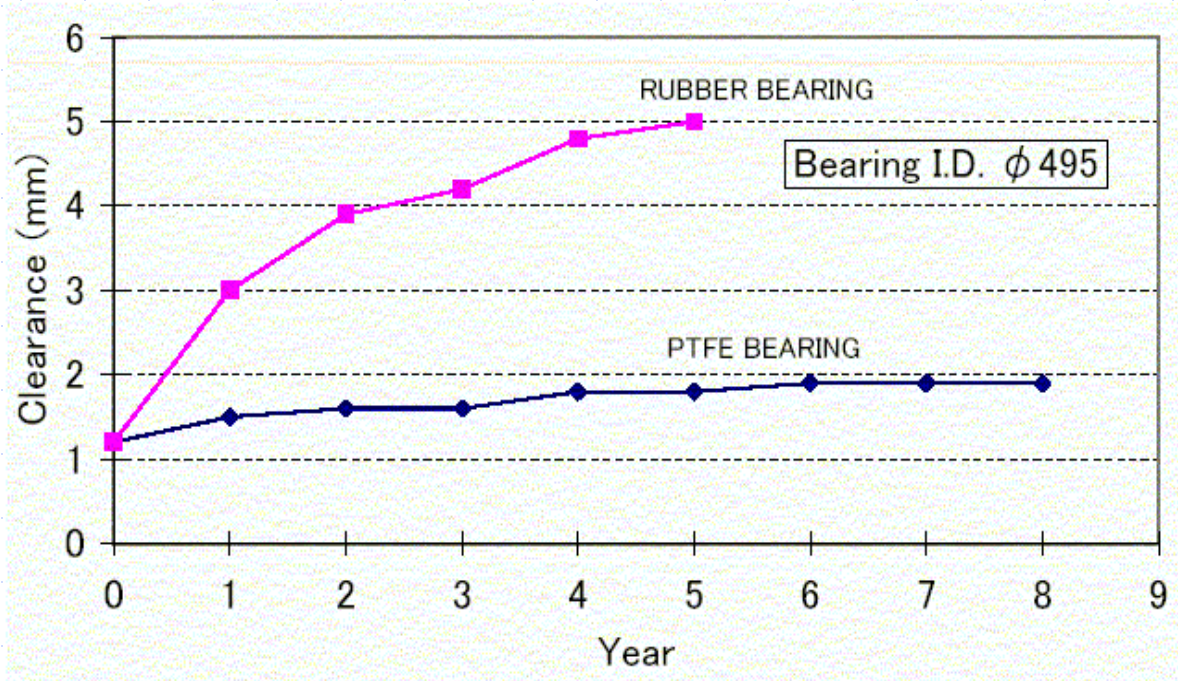

# Fig. 17 Change of clearance on a Guided Missile

## Destroyer

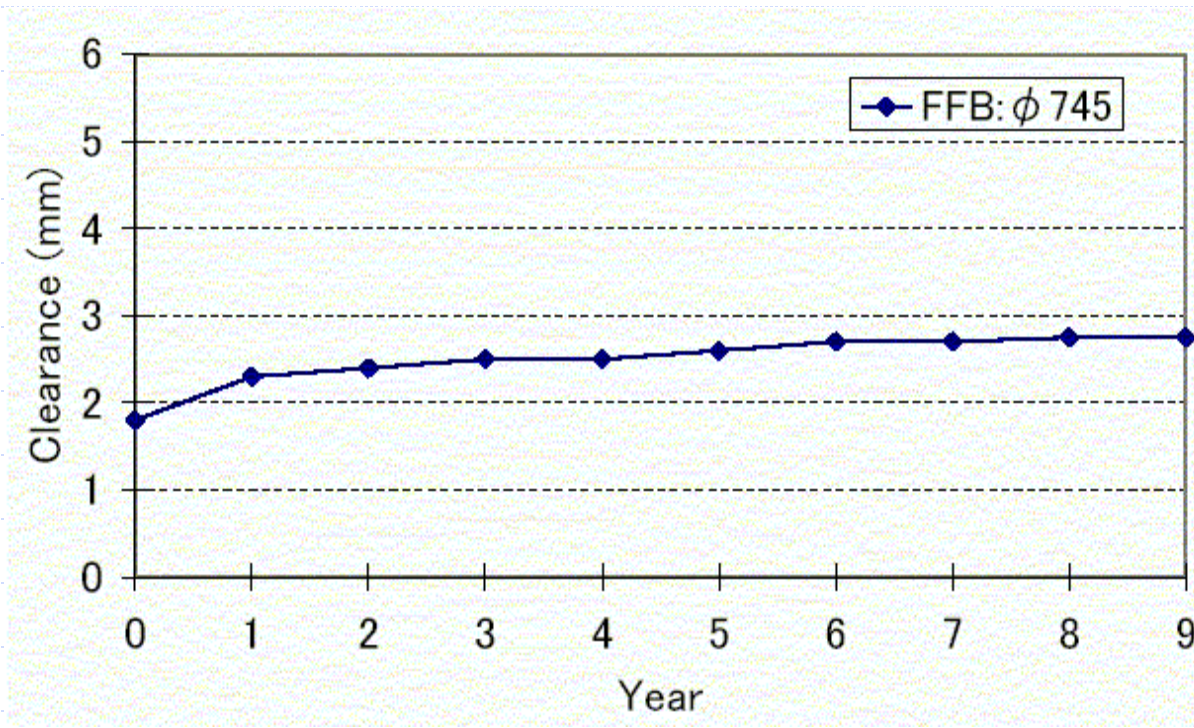

# Fig. 18 Outlook of bearing on a Guided Missile Destroyer



# Fig. 19 Structure of cruising ferry

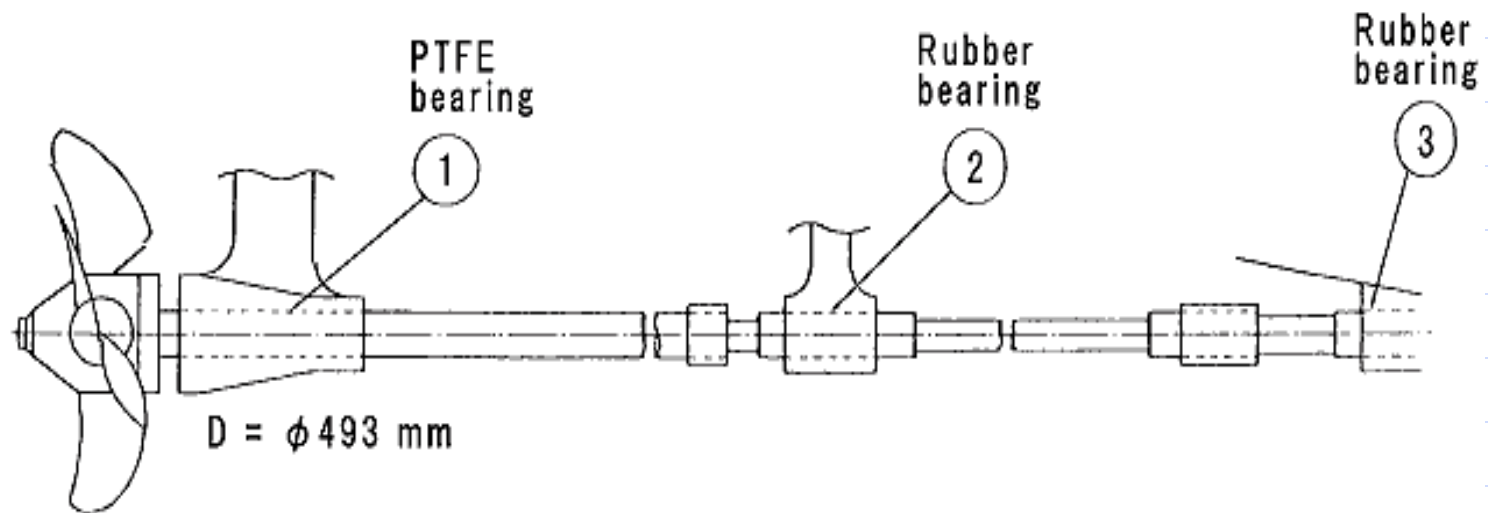

**Fig. 20 Clearance of bearing at position ①**

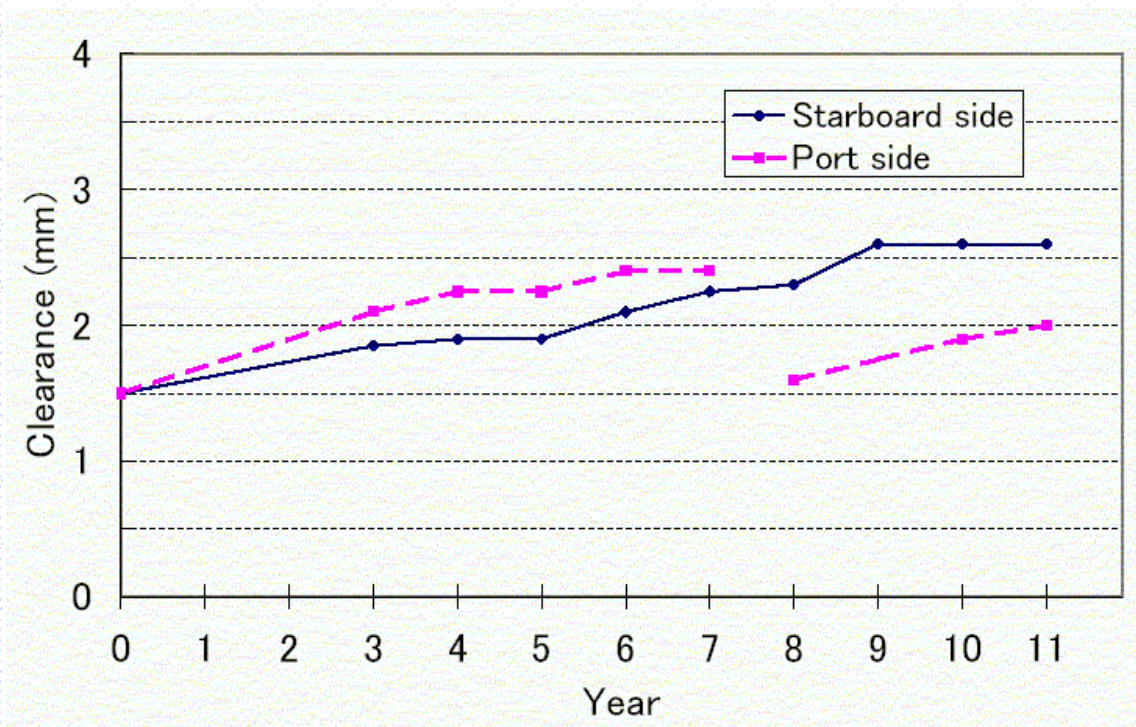

**Table 10 Reference list of PTFE compound bearing**

<b>No.</b>	<b>Type of Vessel</b>	<b>Delivery</b>	<b>Bearing Size</b>	<b>Q'ty</b>
1	Fishing Boat	May-03	Strut ; Ø305 x 1180L	2
			S/T ; Ø305 x 1180L	2
2	Fishing Boat	Jun-03	Strut ; Ø198 x 600L	2
			S/T ; Ø198 x 600L	2
3	Fishing Boat	Oct-03	Strut ; Ø241 x 900L	2
			S/T ; Ø241 x 900L	2
4	Fishing Boat	Feb-04	Strut ; Ø165 x 570L	2
			S/T ; Ø165 x 570L	2
5	Ocean Tug Boat	Apr-04	Strut ; Ø368 x 1300L	2
			S/T Aft ; Ø368 x 700L	2
			S/T Fwd ; Ø367 x 700L	2
6	Supply Boat	May-04	Strut ; Ø203 x 700L	1