



**DYNAMIC POSITIONING CONFERENCE**  
**September 28-30, 2004**

---

**DP Design and Control System**

Status and Inventions in Electrical Power and Thruster  
Systems for Drillships and Semi Submersible Rigs

Alf Kåre Ådnanes, ABB Marine Oslo, Norway  
Brenda Wolak, ABB Marine Houston, USA

---

## Abstract

During the years of 1995-2000, there were ordered a large number of drill ships and semi submersible drilling rigs for operations at deep water, up to 10,000 feet. For the first time, dynamic positioning by use of electrical, variable speed azimuthing thrusters was applied in a larger scale for deepwater drilling. AC drives became state-of-the art motor drive technology also for higher power levels, and AC drilling started to substitute the traditional DC drilling systems.

After several years of low level of new building of DP drilling vessels, there are signs that the new building activity will increase, due to reduced known petroleum reserves and an increasing demand of oil and gas products.

It is now the time to sum up experiences during these years of operation. Also, the solutions used in the late nineties starts to approach ten years of age, and even though there has been limited investment in new building drilling vessels the recent years, the technologies used in such applications have been developed further.

This presentation focuses on the developments within systems and products for electrical power generation and distribution, and variable speed drilling and thrusters drives – the so-called electrical package.

## Introduction

Much has happened in the drilling business since the deepwater drilling activities were started in the mid nineties. More than 25 deepwater drill ships and semi submersible drilling rigs with DP and high station keeping capability are put in operation for exploration, mainly in GoM, Brazil, West Africa, and Canada. In this period, there has also been a substantial merging between drilling companies and contractors, where several technical engineering and operation teams with different backgrounds and technical preferences are melted together in the new companies.

The operation cost and potential loss of income due to off-hire are substantial for deepwater drilling vessels, with day rates in the order of USD 200,000. Reliability and availability of the station keeping system has been of essential importance in the selection of solutions, and the actors in the business ended up at quite different topologies and solutions.

With the diversity in the merged drilling companies' technical solutions, there should be a good opportunity to evaluate the different solutions based on the experiences from years of operation and share this among the players in the field. Some aspects will be raised in this presentation, however, most of the operational experience lies within the drilling operators and contractors, and hopefully, this experience will be made available and shared to the benefit of the whole industry.

Although the level of new building of deepwater drilling vessels has been low during the last 3-4 years, the technical development has continued based on the changing requirements in other marine industries. No major innovation steps have been introduced, the developments have been more incremental, and solutions used in other industries are adapted to marine and offshore requirements, as well as new makers are entering to the market. This presentation aims to describe the recent progress in electric power technologies, available for the users today.

## System description

Deepwater drilling vessels are equipped with a station keeping system. Due to the complexity, costs, and performance of mooring at deep water, dynamic positioning system is normally used for station keeping, Fig. 1.

The station keeping system does not only include the DP controllers and position reference systems and sensors, but also the diesel-electrical power generation plant and electrical distribution system, with electrically driven thruster units as actuators to produce the necessary thrust to stay at the desired position or trajectory. The corresponding auxiliary and control systems must also be considered in the overall station keeping system design.

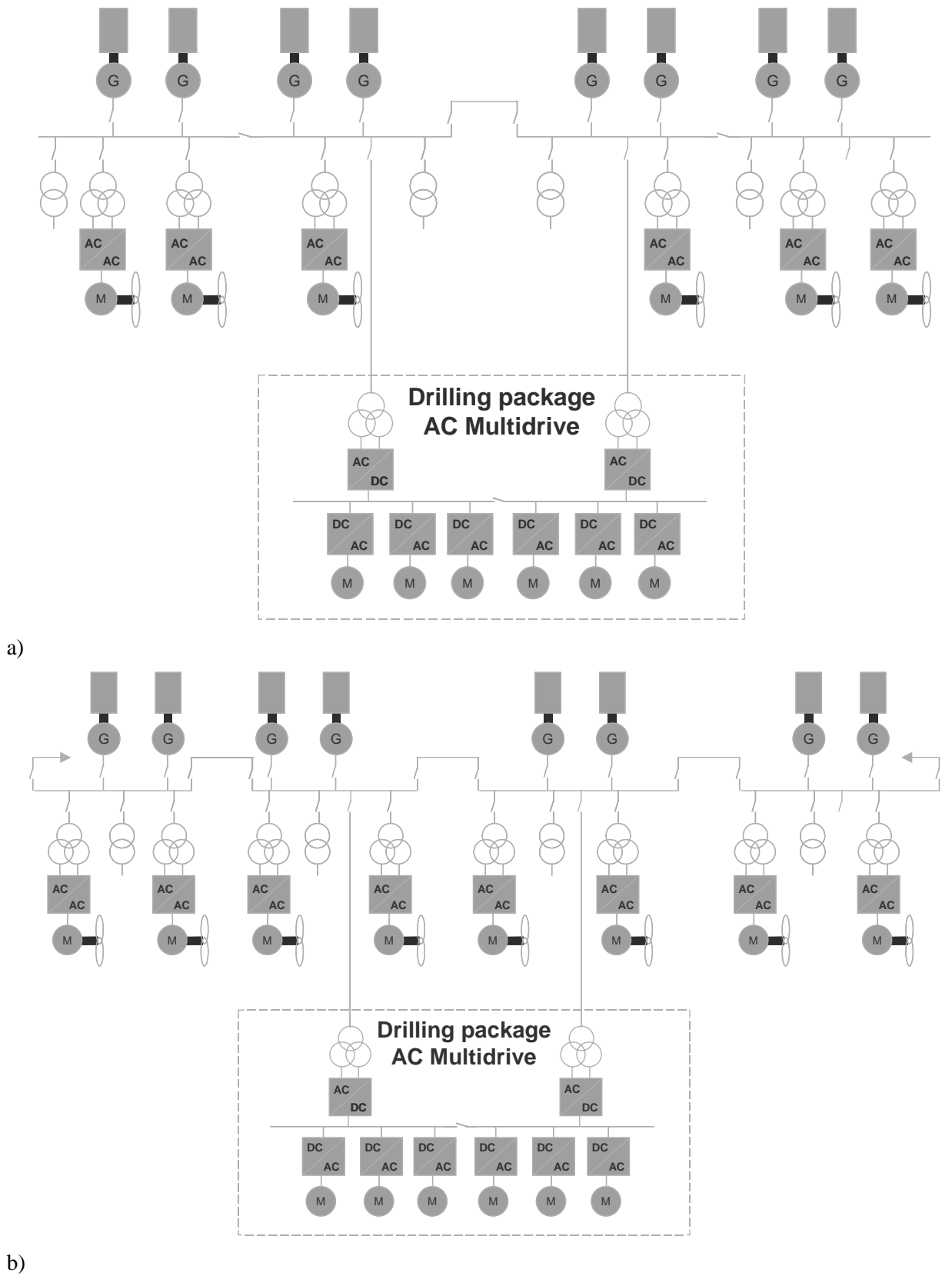

*Fig. 1: The electric power and thruster system is an integral part of the overall station keeping system for a semi submersible rig.*

The electrical power system is characterized by the common power plant for station keeping equipment, drilling equipment, and vessel loads. The power plant is typically split into two or more segments, separated functionally for DP class 2 operations and also physically by fire and flooding segregation for DP class 3 operations. The number of splits is a trade-off between the costs and weights for installed equipment, and the costs of segregation, and the system's ability to meet the operational requirements. The more splits, the less additional or redundant power installation is required to obtain the class notation for a specified weather window, since the rules requires station keeping capacity to be maintained until safe shut-down after any single failure. The worst-case single failure is normally a switchboard short circuit (DP class 2) or a fire and flooding scenario (DP class 3).

For the drilling vessels, mainly two basic concepts have been installed:

- A. Radial main bus, with two or more main power buses either operated with normally open or normally closed bus-tie(s) in a string configuration, Fig. 2a.
- B. Ring main bus; with three or more main power buses possible to connect with bus-ties or feeders, normally with at least one open bus-tie/feeder in a radial configuration but also with all bus-tie/feeder breaker closed in a closed ring main bus configuration, Fig. 2b.



a)  
b)  
*Fig. 2: Example electrical power system configuration a) for a drill ship with radial main bus system, and b) a ring main bus system for semi submersibles.*

As station keeping thrusters, most of the deepwater drilling vessels utilizes fixed pitch, speed controlled azimuthing thrusters /1/. These were selected for most of the vessels in order to obtain high efficiency and low fuel oil consumption. Also, there was at the time a high concern for fixed speed controllable pitch thrusters, which were reported to have high failure rates in DP vessels /2/, which favoured the FPP azimuthing thrusters with less mechanical complexity. Podded thrusters were introduced in the late nineties as thrust units, where the electrical motor is connected directly to the propeller shaft in a submerged, azimuthing podded unit with no gear transmission. This concept was originally derived from podded propulsors for ships, and adapted for station keeping use, Fig. 3.

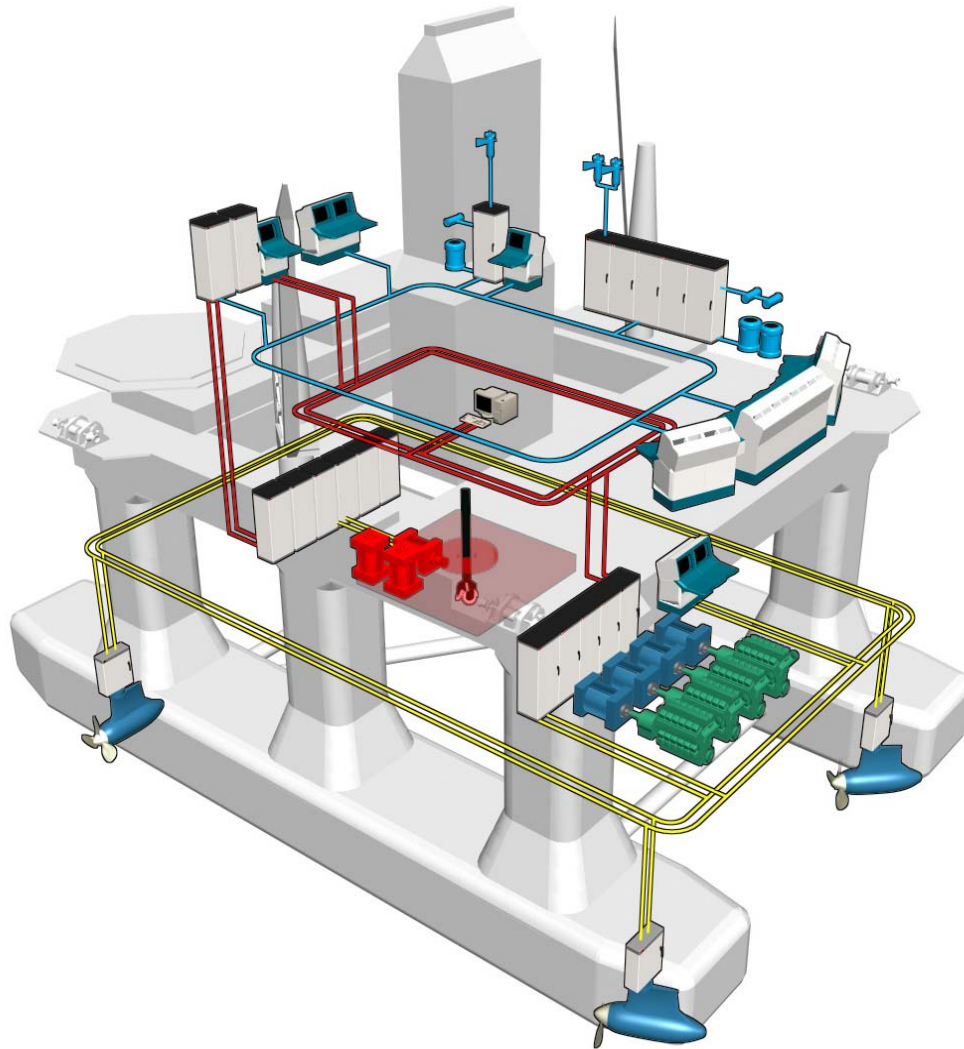

*Fig. 3: Semi submersible drilling rig with four podded azimuthing thrusters.*

## Some Experiences

### General

The generation of drilling vessels build in this period has shown to be efficient for drilling with, in general, a high availability and reliability. This could not be achieved without the competence of operators and crew of the vessels, who has managed to operate these advanced vessels with confidence and managed to resolve technical problems with a minimum of interference with the drilling operations. However, it also shows that the technical solutions in general has proven to be reliable and robust with a high integrity to faults and that the installed station keeping capability has sufficient margins to tolerate faults under normal environmental conditions.

Sooner or later, any technical equipment may and will fail. A failure may give reduced capability of the installation until the fault is repaired and the equipment is put into operation again. In a robust and fault tolerant system the operation can continue without interruption as long as the remaining station keeping capability is sufficient for the prevailing weather conditions.

There are, however, certain topics that repeatedly show up as common concerns, such as:

- Response time and dynamics of load reduction and blackout prevention
- Diesel engine governor and AVR fault tolerance
- Special characteristics of large electrical installations for ships and rigs
- Harmonic distortion
- Fault diagnostics and repair times

### Load reduction and blackout prevention

The diesel-electrical power system has better performance and fuel economy if the power management system controls the number of running engines in the power plant to match the load demand with high loading of the diesel engine. The optimal load with respect to fuel consumption, tear and wear, and maintenance is typically about 85% of maximum continuous rating, MCR.

With a high load at the running engines, the system gets more vulnerable to faults in the system, such as a sudden trip of one diesel engine generator. The remaining, healthy engines will experience a step load increase and possible overloading and in worst case under frequency trip unless the functionality in the system reduces the load power in accordance with the generating capacity.

In a modern drilling vessel, this load reduction and blackout prevention function is distributed and handled by several subsystems, such as:

- Power management's load management and blackout prevention functions
- Dynamic positioning system's power limitation functions
- Thruster drive's load reduction and load phase back functions
- Drilling drive's load reduction and load phase back functions

The ability to withstand such faults is also highly depending on design and engineering methods and solutions, such as:

- Load capability and dynamics of the diesel engine
- Governor and AVR configuration and settings
- Generator and switchboard protection relay settings
- Critical equipment should be fault tolerant with loss of power ride-through functionality

In DP vessels with high efficient speed controlled fixed pitch thrusters, the total load under normal operation is so low that the power plant runs optimal with few, often only two running diesel engines. In order to utilize this saving potential, there challenge is to design and tune the system to be capable of handling fault scenarios within a time frame not compromising the stability of the power supply.

Fig. 4 shows, for illustration, the diesel engines capability to maintain the frequency for the load step associated with the loss of a parallel run engine. In typical installations, it has been seen that the actions of load reduction and blackout prevention must be effective within less than 500ms in order to not compromise power system stability and limit the flexibility of operation.

Several solutions are in use and the operators and owners have different preferences. However, some common conclusions can be made on what is typically required for the blackout prevention functionality:

- Thruster and thruster drives:  
Variable speed FPP thrusters must have a load reduction scheme, either monitoring the network frequency and/or receiving a fast load reduction signal from the power management system, either as a power phase-back signal, maximum power limitation signal, or – if well coordinated – fast RPM reference reduction.  
In order to avoid instabilities in the network frequency, the load reduction should be as precise as possible, and implemented in order to dampen potential oscillations.  
Fixed speed CPP thrusters do not have fast enough response time for blackout prevention. These must be included in the power management's load shedding scheme.
- Drilling drives:  
Similar to the requirements of the thruster drives, with built-in priorities for the individual drilling drives.
- Power management system:  
By class requirements, the power management system must include blackout prevention with load reduction/load shedding functionality. It was observed earlier, that the response time in this system was too long to obtain the desired level of fault tolerance without a fast acting, stand-alone load reduction scheme in the thruster drives. With the knowledge of today, this has been claimed solved by use of fast acting, and possibly event-triggered load reduction algorithms.
- Dynamic positioning system:  
The dynamic positioning system is also equipped with a power limitation function, normally based on a permitted maximum power consumption signal from the power management system. Generally, this has shown to be effective in avoiding overloading of the running plant, but not fast enough to handle faults and loss of diesel-generator sets.  
Of importance is also that the power limitation also is considered in manual and joystick control of the thrusters.

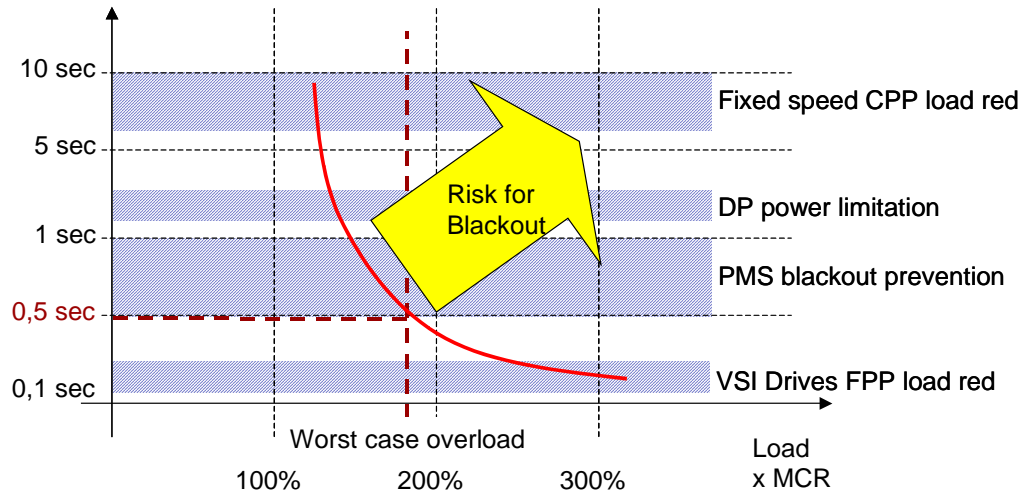

Fig. 4: Regulation time constants for power reduction, with maximum response time in the order of 500ms (Illustrative only).

Based on experience, it is recommended that all load reduction and blackout prevention functions described above are installed and well coordinated, tuned and tested during commissioning and sea trial. Also, the need for retuning and testing must also be considered after modifications in the installation that may affect the coordination.

A typical coordination diagram is shown in Fig. 5. Auto start and auto stop limits shows the level and time settings for load dependent automatic start and shutdown of the engines. Available power will under normal operations be within these limits. Upon faults, and sudden loss of engine, the available power is being reduced. The power reduction functions of the DP can be distinguished between critical or non-critical situations, allowing the DP to take all available power after possible load reduction and load shedding of non-essential consumers or consumers with lower priority.

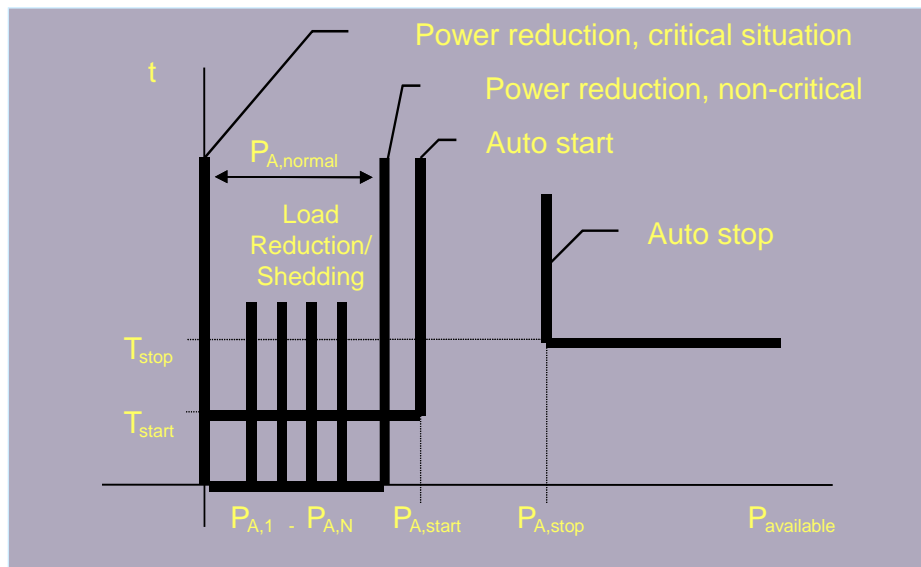

Fig. 5: Coordination of auto start/stop and blackout prevention functions (example).

### Diesel engine governor and AVR fault tolerance

Although the rules and regulations have allowed for DP operations with closed bus ties in the electrical power system and one commonly connected power plant, the practices were until mid nineties to split the network into two or more separated sections in DP 2 or 3 operations.

With the developments on switchboard protection relays, and thruster drives with fast response time and power ride through functionality together with new power management systems with more precise and faster load reduction and blackout prevention functions, this has changed and it is now more common to operate with normally closed bus tie breakers and also with closed ring main bus. This development is motivated by the benefits of better and more flexible utilization of the installed generating capacity and to gain an improved fuel economy. The fuel savings for optimised loading of running engines have shown to be significant.

In such systems, it has been observed that under some load and operating conditions, certain faults in governors and automatic voltage regulators, AVRs, can be difficult to identify with a regular protection scheme. In worst case, faults have shown to interfere with healthy equipment causing undesired shutdowns and in some cases even blackout.

Developments in digital generator protection relays with multifunction and programmable protection logics have enabled a possibility to combine protection functions in new manners, and include logic and algebraic functionality into the protection scheme. This has significantly improved the protection relay's ability to detect governor and AVR faults, and improved the system's fault tolerance to such faults.

Fig. 6 shows a possible monitoring scheme for AVR, including correlation functions of multiple variable and voting functions for multiple gensets. Such functionalities can be installed in the modern, programmable multifunction generator protection relays, or in separate logic controllers for retrofit and upgrades.

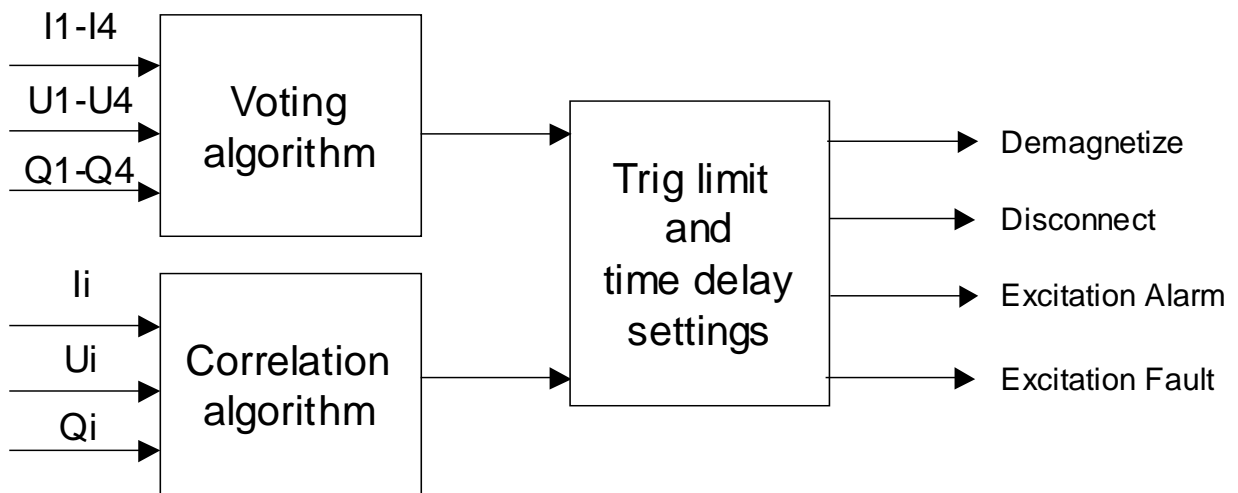

Fig. 6: A monitoring scheme for AVR fault detection.

### Special characteristics of large electrical installations for ships and rigs

The electrical networks in marine systems differentiate from land-based industrial network in several ways. The most obvious difference is that the power installation on ships and rigs are stand-alone systems, isolated from a large power grid. Often, the installation is regarded to be “weak” in respect of transient inductances and transient performance.

In weak networks, the voltage variations due to starting and stopping of large consumers, fault transients, and network stability are of concern. With a few exceptions, as described in section 4.3, the installations generally have shown to perform as expected with high robustness to this characteristic.

However, due to the concentrated installation, and the relatively large volume of cabling, the system capacitance is relatively high and creates a stiff system for sub-millisecond transients. While the rise time of normalized impulse voltage tests for electrical equipment may be up to 1.2 $\mu$ s, measurements have shown that the switching transients in ship networks are significantly faster. Even though the magnitude of the switching transient normally is far below the normalized test amplitude, the steep voltage rise may alter the internal voltage distribution in the windings of the equipment and cause local over voltage and insulation breakdown, see Fig. 7a). There have been observed several equipment faults where such transients are suspected to be the root cause.

The means to reduce the risk of insulation break down are:

- Insulation level coordination of the complete system
- Selection of circuit breakers with low voltage transients
- Selection of insulation material with high tolerance to fast voltage transients
- Selection of winding designs with a better internal voltage distribution for even fast transients, Fig. 7b).
- Over voltage protection, e.g. with surge arrestors

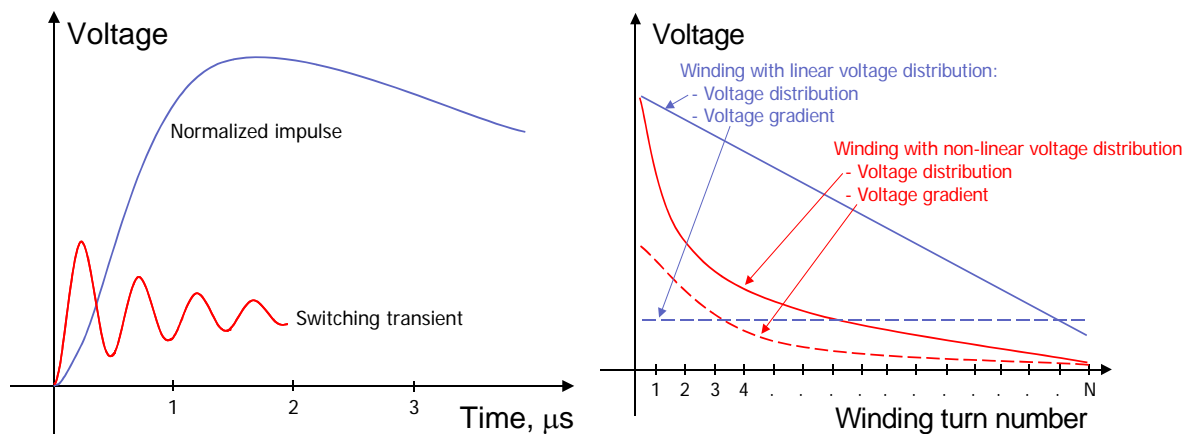

Fig. 7: a) Comparison of switching transient with standard transient for transformers.  
 b) The corresponding voltage distribution in two different electric windings.

### Harmonic distortion

Using frequency converters and other non-linear loads, the load currents are not sinusoidal and will create disturbances to the network voltage. This is called harmonic distortion, and is measured by the content of harmonic voltage components (with frequency in multiples of the fundamental, normally 60Hz, frequency). A common measurement index for the harmonic distortion is the root-mean-square of the harmonic components in relation to the fundamental component, which is notated as the Total Harmonic Distortion, THD. For the earlier generation drilling rigs with DC drilling drives, SCRs, the level of harmonic distortion could be very high, and in the order of 15% THD (voltage THD). At such high levels of voltage distortion, there were in some installations experienced malfunction of equipment, leading to a high attention to management and reduction of harmonic distortion, and also more strict limitations in class rules and regulations.

During the last decade, there has also been a shift in applied motor drives technology in marine applications. Voltage Source Inverter, VSI, type frequency converters with induction machines have been introduced in both drilling applications and in thruster drives applications. The level of harmonic distortion of 12-pulse VSI converters was significantly reduced from the typical installations with DC drives, and there has, with few exceptions, not been reported any problems related to harmonic distortion in these installations. The solutions that were designed for, and installed in the majority of drill ships and rigs appear to be appropriate with respect to harmonics.

Fig. 8 shows the principles of using 12-pulse VSI converters. Fig. 8a) shows a VSI converter with two series connected full-bridge diode rectifiers, which are fed from a three-winding transformer. Series connection is commonly used in medium voltage converters (>1000Vac), in order to reduce the voltage stress on each component. Similarly, the inverter switching elements, here shown IGBTs, are series connected in a neutral clamped inverter topology, resulting in better utilization of the semiconductor components, with reduced ripple in the load current and torque even with moderate switching frequency.

In low voltage converters (<1000Vac), the rectifiers are typically series connected. Fig. 8b) shows a topology where several inverters are connected to a common DC link. The DC link can be split by use of isolators, and each side is connected to a 12-pulse diode rectifier. This converter topology with multiple inverters fed from a common DC bus is called a multidrive, and is used for drilling drives, cargo handling drives, and can also be used for thruster drives and/or main propulsion. The braking resistors are used if the load can produce regenerated power, e.g. under very fast speed reversals or other braking conditions, without sending power peaks back to the network.

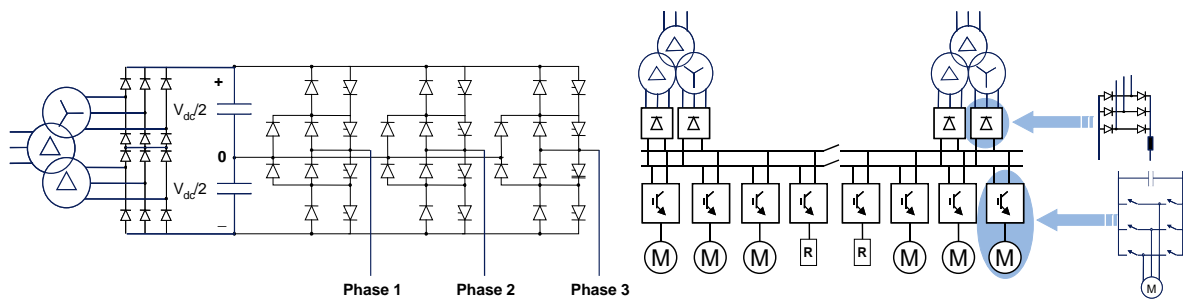

a) *12-pulse Voltage Source Inverter (VSI) in Medium voltage single drive for thrusters and b) Low voltage drilling multidrive.*

## Technology Evolution 1998 – 2004

### Evolution

A continuous evolution, rather than major technology steps has characterized the technology development of electric power systems for use in drilling vessels. One of the reasons is the strict requirements to reliability and availability, giving preference to well proven solutions with track record from other applications.

Technologies applied in other industries and in other marine segments have been adapted and made available to the offshore and drilling applications. Looking at the solutions that are used for new buildings of today, there are obvious similarities, but some important new features have been taken into use and will be highlighted in this chapter.

### Electric Power Generation

The synchronous generators have for decades been used in electric power generation, and the technology is basically unchanged, with exception of adapted production methodology and modernized dimensioning tools.

New technologies, such as fuel cells, high-speed generation, and brushless DC generation are constantly evaluated, but yet no breakthrough is expected in the foreseeable future here.

However, digital programmable automatic voltage regulators, AVRs, have started to be standard for marine generators, enabling more advanced and application specific controls and functionality at low-level generator control. Normally, reactive power sharing between parallel-connected generators is well achieved with voltage droop control, without utilizing the built in reactive power sharing function of most digital AVRs.

The enhanced functionality of the digital AVRs opens for new possibilities in advanced generator protection and controls, stand-alone, or together with the generator protection relays normally delivered as a part of the main switchboard, as described below.

### Electric Power Distribution

The electric power distribution system is normally considered as the main switchboards and distribution panels with auxiliaries and protection relays and the distribution transformers. There has not been any single major technology step in this field, but the solutions available today are generally less spacious, and easier to install, commission, and maintain.

In medium voltage switchboards, two types of breaker technology have been applied; gas insulated (SF<sub>6</sub>) circuit breakers and vacuum insulated breakers. It is reported that the switching characteristics of vacuum breakers are significantly improved with respect to switching transient voltage than experienced some years ago. Since the characteristics of ship networks as described above are of special concern, the switching characteristics of the circuit breaker must be addressed in the insulation coordination and selection of matching equipment.

The protection relays for the power generation and main consumers are normally included in the main switchboard. Multifunction digital protection relays with possibility for application specific programming and protection logics are used in most installations. The programmable protection relays enable the use of more sophisticated solutions for protection and monitoring such as AVR fault monitoring (section 4.3) in parallel operation.

### Variable Speed Drives

In drilling vessels, the high power variable speed drives are used for drilling drives, mooring winches, and thruster drives. Smaller drives can be used for auxiliaries, pumps, fans, etc., to improve the performance and reduce losses.

A technology shift was initiated for offshore and drilling vessels as early as around 1990, where voltage source inverters, VSIs, were installed for thruster and propulsion drives also in high voltage and MW applications. Among the total installed power plants, nearly 70% of the drilling vessels build after 1995 were utilizing this technology, while the remaining are installed with current source inverters (CSI) /1,3/.

This development has accelerated the last years, and VSI converters have now more or less replaced other configurations in the high power applications. Today, they are available for power levels up to 27MVA in medium voltage converters (>1000V).

While the CSI topology was based on thyristor semiconductors, the VSI converters normally have passive diode rectifiers and switching semiconductors in the inverter side. Traditionally, only GTO (Gate Turn-Off) thyristors were available as switching component in high voltage converters. During the late nineties, two alternative components were launched, the IGCT (Integrated Gate Commutated Thyristor) and the medium voltage IGBT (Insulated Gate Bipolar Transistor).

In ship applications, space is often a limited resource, and multidrives (Fig. 8b) are now not only used for drilling applications in order to save space and weights, but also drives for thrusters, propulsors, winches, etc., have utilized similar configurations. A multidrive will reduce the size of the feeding switchboards, transformers, and possibly cabling and supply units of the frequency converter – especially when used in motor drives, which are not utilized simultaneously at full load, such as; thruster/cargo handling drives and winch/drilling drives.

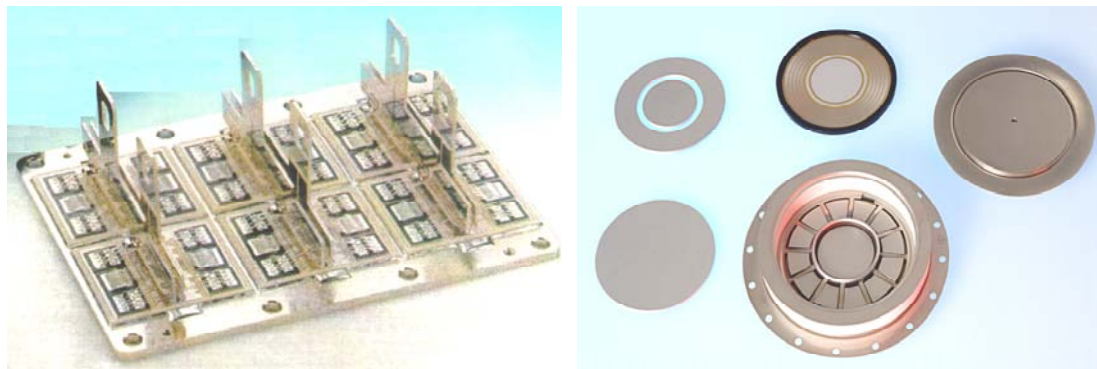

Fig. 9: a) Low voltage IGBT module and b) medium voltage IGCT press pack component.

### Electrical Podded Thrusters

The electrical podded thruster was originally developed as a propulsion unit for ships around 1990. The principle is as explained in Fig. 10, a thrust device where the propeller is directly driven by an electrical motor in a submerged podded house. The pod is capable of rotating freely, giving thrust in 360 degrees without inherent limitations.

The first pods delivered as station keeping thrusters for a semi submersible drilling rig were installed around 1999-2000 /4/ In the first rigs, there were four units, one in each pontoon end that provided the necessary thrust capability /5/. The advantage with using few units is that the power rating of each unit is

higher and this will typically reduce the overall costs, and the thruster interference is reduced. The disadvantage is that with one unit out of operation, a larger portion of the total installed thrust capacity is not available, and the DP maneuverability with only three remaining units may become more difficult.

The smaller size pods were launched as station keeping thrust units later, and is today under commissioning in the first semi submersible rigs. While the overall conceptual design is similar to the installations in the earlier generation semi submersibles, with two units in each end of the pontoons, eight units in total, it has been shown that the podded units may give more thrust with less losses per unit of electrical power /6/. Tilting of the complete motor module instead of the nozzle increases the hydrodynamic efficiency, and the direct motor connection to the shaft eliminates mechanical gear losses in the power transmission.

The direct connection and dry housing of the electrical pod, compared with the oil-filled housing of mechanical azimuth thrusters, also enables bearing and sealing designs with fewer moving parts and less risk and consequence of sealing failures.

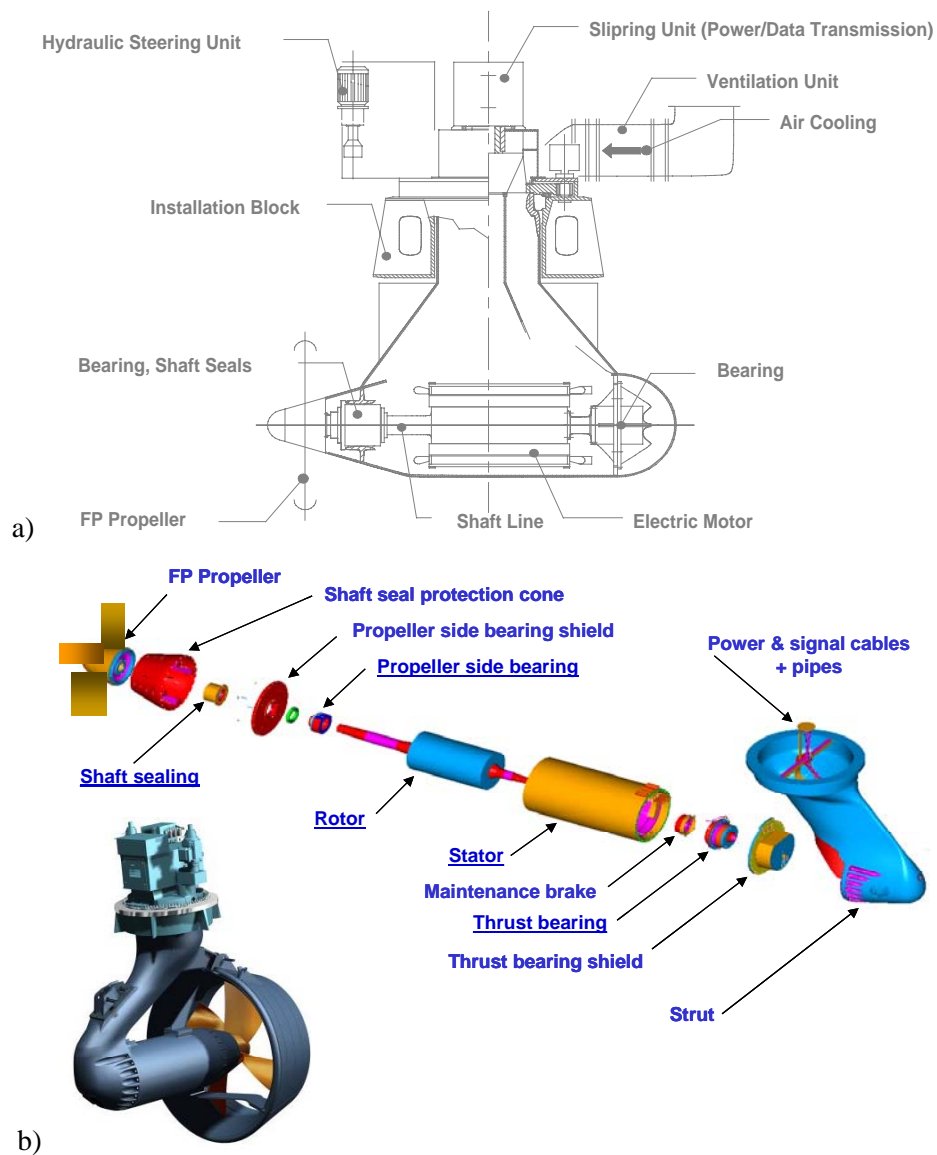

Fig. 10: a) Large podded propulsors (>5MW) with asynchronous or synchronous motor for ships and b) Podded thruster (<4.5MW) with permanent magnet motor for station keeping in drilling vessels /1/.

## Summary

More than 25 deepwater drilling vessels have been put in operation the last 7 years, with several different designs and equipment solutions. Although much of the design principles and basic configuration of the electric power generation and thruster plant is similar on the vessels, there are also distinct differences in selection of technology and solutions. The accumulated experience in the industry is today significant, and if this can be shared and utilized, it would form a good basis for design of next generation deepwater drilling vessels.

It is the general impression that the performance of the fleet has been good, with good availability of station keeping power and thrust capability for the operations. The selection of variable speed AC drive technology in the industry has shown to give low operational costs with the possibility to operate the vessel's engine plant with a high degree of flexibility and in an optimum manner.

From the feedback from owners and operators, and from own support functions, there are certain lessons to be learned, and some issues remain to be solved. New technologies and products are developed and ready to be used in the next generation of deepwater drilling vessels. By combining the best of technologies and utilizing the operational experience, there are good reasons to expect successful designs of next generation of deepwater drill ships and semi submersible rigs.

## References

1. Ådnanes, A.K., Sørensen, A., Hackman, T.:  
*Essential Characteristics of Electrical Propulsion and Thruster Drives in DP Vessels*,  
DPC Houston, Texas, 1997
2. Wilne, T.: *Thruster reliability: The problems and effects of components failures and drive selection*, paper no. 16, 1st international conference on diesel electric propulsion, 20-23 May 1996, Ålesund, Norway
3. English, P.:  
*The evolution of Marine and Drilling Drives in Today's market*,  
DPC Houston, Texas, 2001
4. Nicod, J-P.:  
*Pod concept and its application*, Diesel electric propulsion 26-29 April 1998, Helsinki, Finland.
5. Reynor, S.:  
*The benefit of podded propulsion in the offshore market*, DPC Houston, Texas 1998
6. Mattila, M., Ylitalo, J.;  
*Semi Submersible Rig, "The Reliable Solution with Minimum Thrust Losses"*,  
DPC Houston, Texas 2002