



DYNAMIC POSITIONING CONFERENCE
September 16-17, 2003

FPSOs and Shuttle Tankers

HiLoad, Introducing DP to Standard Tankers

Bjørn Egil Gustavsen
Remora Technology (Houston)

Table of contents

1	Abstract	2
2	Introduction	2
3	Background.....	3
4	System Description.....	4
5	Integrated Control System.....	6
5.1	Machinery Systems	7
5.2	Navigational Systems.....	7
5.3	Dynamic Positioning (DP) System.....	8
5.4	CCTV System	8
5.5	Safety Systems	9
5.6	Operation Command Centre (OCC).....	9
6	Operation Description.....	10
6.1	Operation Sector.....	10
6.2	Tanker Approach.....	10
6.3	Docking.....	11
6.4	Loading Hose Connection.....	12
6.5	Loading	12
6.6	Undocking.....	12
6.7	Idle Condition.....	12
7	Verification of Position Keeping Capability	13
7.1	Weather Vaning and Operational Philosophy	13
7.2	Numerical Simulation Study	15
7.3	Model Test	16
7.4	Wind Tunnel Test.....	19
7.5	Main Conclusion	19
A	APPENDIXES.....	20
A.1	Data Plot Numerical Simulations	20
A.2	Data Plot Model Test.....	30
A.3	3 rd Party Verification	39
A.4	Reliability and Availability	40

1 Abstract

Remora Technology together with ConocoPhillips Inc, has developed the HiLoad technology over the last three years for loading and discharging of oil at offshore locations. The HiLoad has been thoroughly engineered and model tested, and is ready for fabrication.

The HiLoad (i.e. DP-Terminal) is a dynamically positioned Loading Terminal that will be able to connect to any standard tanker that has a relatively flat bottom. It will dock onto the tanker in a similar way as a forklift picks up a pallet by use of a ballast system installed in the unit. After connection, a high capacity friction attachment system is activated in order to transfer forces from the DP-Terminal to the ship.

The DP-Terminal is equipped with three thrusters that will be used to keep the tanker in position during the offloading operation. It is equipped with a DP system, allowing the tanker to weather vane, (i.e. no heading control) this enables the DP-Terminal to hold the tanker in position during offloading with limited thruster forces compared to standard DP tankers. This has been documented with numerical simulations and position keeping tests at Marintek in Trondheim, Norway. The work verified that we are able to keep position errors within required limits without excessive use of thruster force.

The DP-Terminal has been particularly developed for Deep Water applications and requires no mooring lines to the seabed.

The technology can also be used for other applications and developments are ongoing for HiLoad as LNG terminal and crude oil receiving terminal.

2 Introduction

The HiLoad is a newly developed system for offshore loading of hydrocarbons, basically intended for deepwater applications. The development has been carried out by Remora Technology, with technical and financial support by ConocoPhillips Inc.

The development work has been carried out in four steps:

1. Conceptual Engineering and Feasibility Study
2. Scale model testing and Full-scale testing of tanker interface
3. Detail Engineering with 3rd party verification
4. Position Keeping Test (DP-Test)

This paper will give a general technical description of the HiLoad offshore loading system, and with emphasize on the station keeping capability for the system. The paper will describe the tests performed and the results achieved. To obtain correct current drag coefficient data, wind tunnel tests where also carried out at DMI Denmark, this will be seen in relation with the model test at Marintek.

3 Background

Offshore loading of oil has been done for many years. Today's offloading technology needs special shuttle tankers with DP-System (North Sea) or standard tankers with tug assist (i.e. CALM buoy, tandem, etc) The goal was to develop a safe and cost effective loading system that could be used in combination with any tanker of opportunity and at the same time increase the operational limits. The DP-Terminal should also be able to connect, offload and disconnect without any tug assistance.

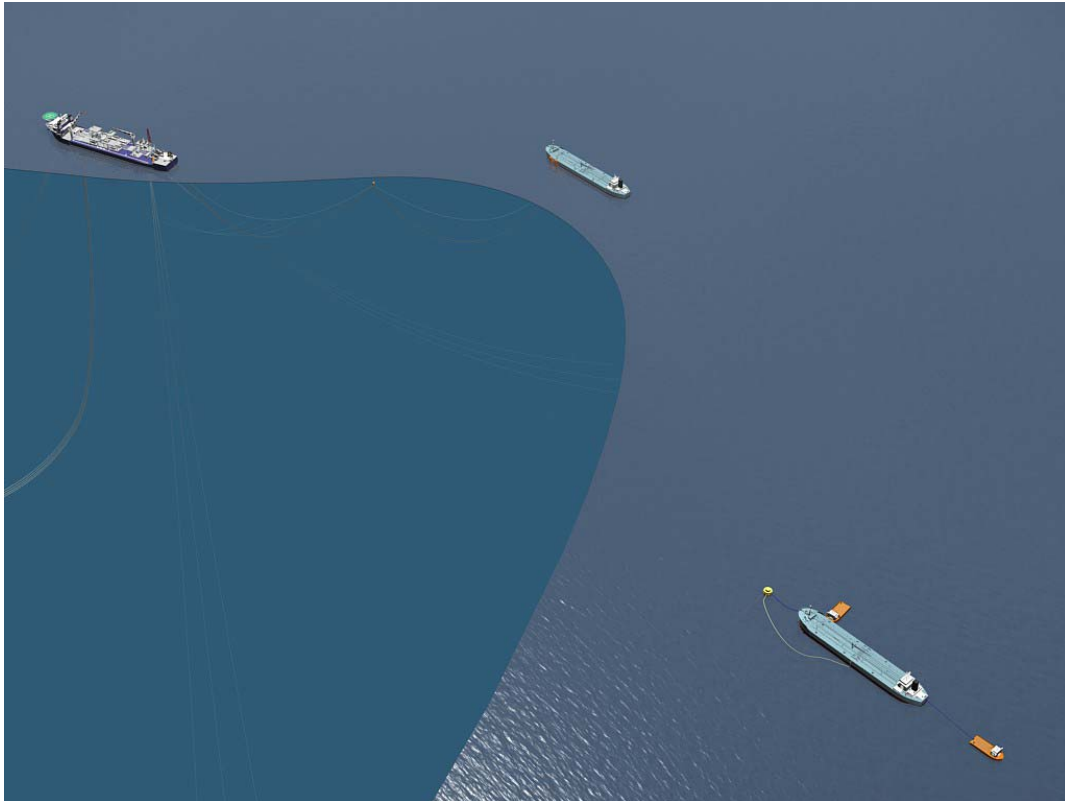

Figure 1 – Architectural Layout CALM and HiLoad

The use of offshore storage using a ship-shape hull permanently moored on location is a very common solution for field developments in most areas of the World. Especially in West Africa this has become a typical approach. Due to very constant wind and current directions, most of the FPSOs/FSOs are installed using a spread mooring system. Offloading is normally done either by use of a CALM Buoy some 2km away, or as tandem offloading from the stern.

The loading rate for such storage offloading is based upon loading of a 1.000.000 bbls tanker in approximately 24h. The DP-Terminal is capable of connecting onto any OCIMF compliant tanker, and keep the tanker within a defined operational area during the loading operation.

Position keeping and disconnecting will be possible in 1-year environmental condition. The DP-Terminal system is site-independent, and will be easy to install and re-locate. FPSO related equipment can be modularized for simple installation and hook-up. Only two parking lines will connect the DP-Terminal to the seabed. All DP-Terminal systems are fully redundant, and no single failure will jeopardize the safe operation of the system.

4 System Description

The HiLoad System consists of the following main components:

- HiLoad Unit
- Oil Transfer Line
- Power and Signal Umbilical
- FPSO Arrangement:
 - Oil Transfer Line and Umbilical Terminations
 - HiLoad Power Supply
 - HiLoad Operation Command Centre
- Parking/Survival System

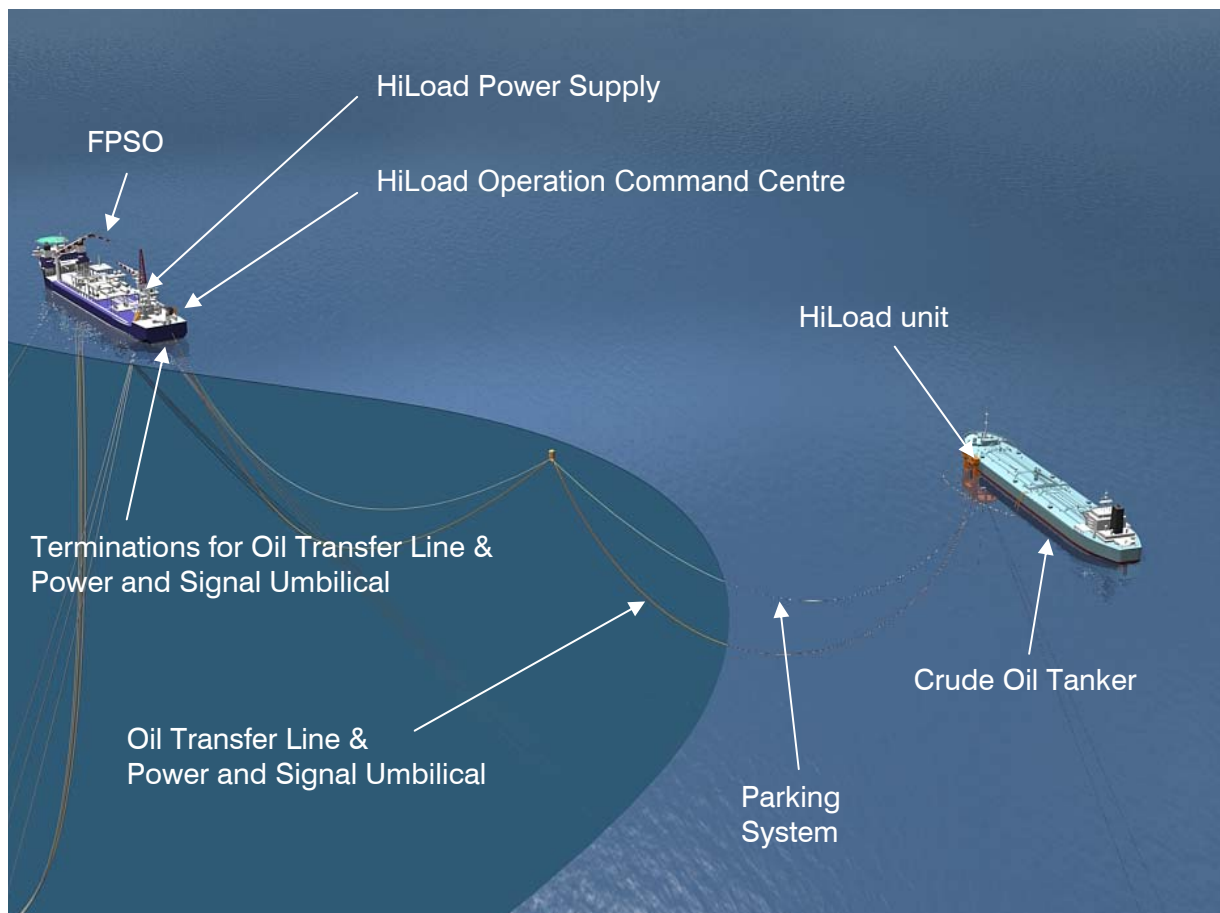

Figure 2 - HiLoad System General Layout

The HiLoad consists of the following main components:

- Steel Hull
- Marine Systems
- Fender and Tanker Attachment System
- Thruster System
- Integrated Control and Automation System
- Hose Reel w/Tanker Loading Hose
- Swivel
- Electrical Systems
- Safety Systems

The DP-Terminal will be hydrostatically stable at all drafts. It carries the weight of the unsupported portion of the transfer hose and umbilical. When disconnected from the tanker, it will be kept at a draft minimizing the environmental loads on the unit. A graphic illustration of the unit is shown in Figure 3.

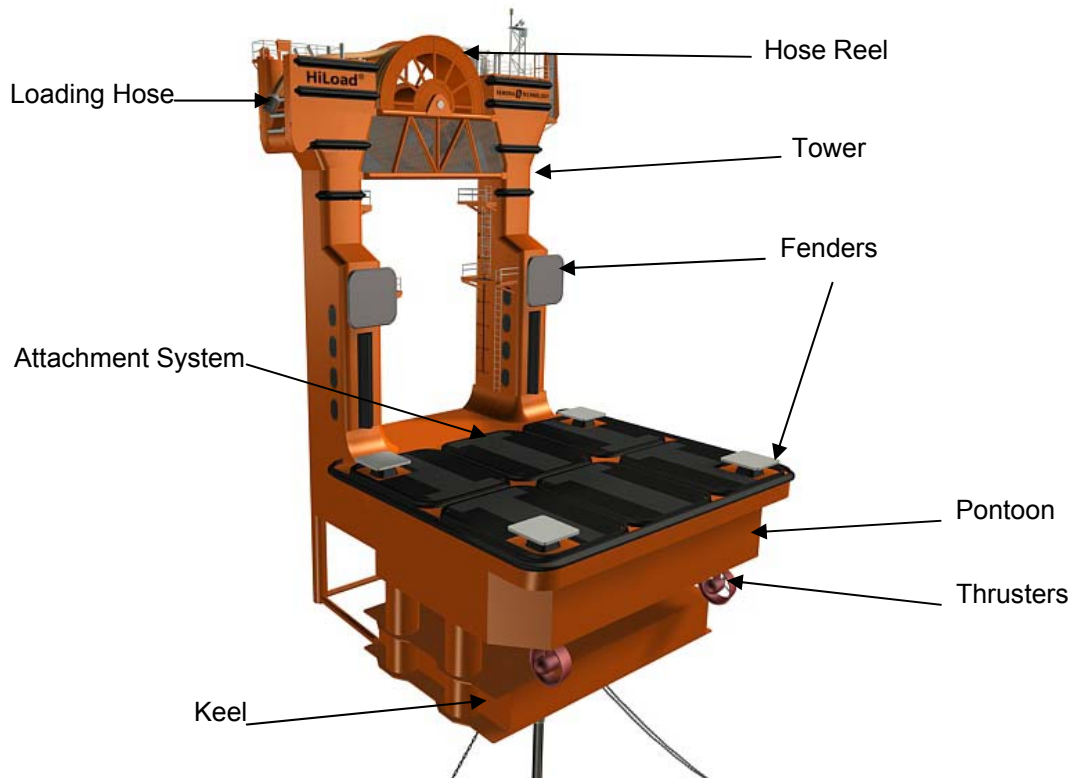
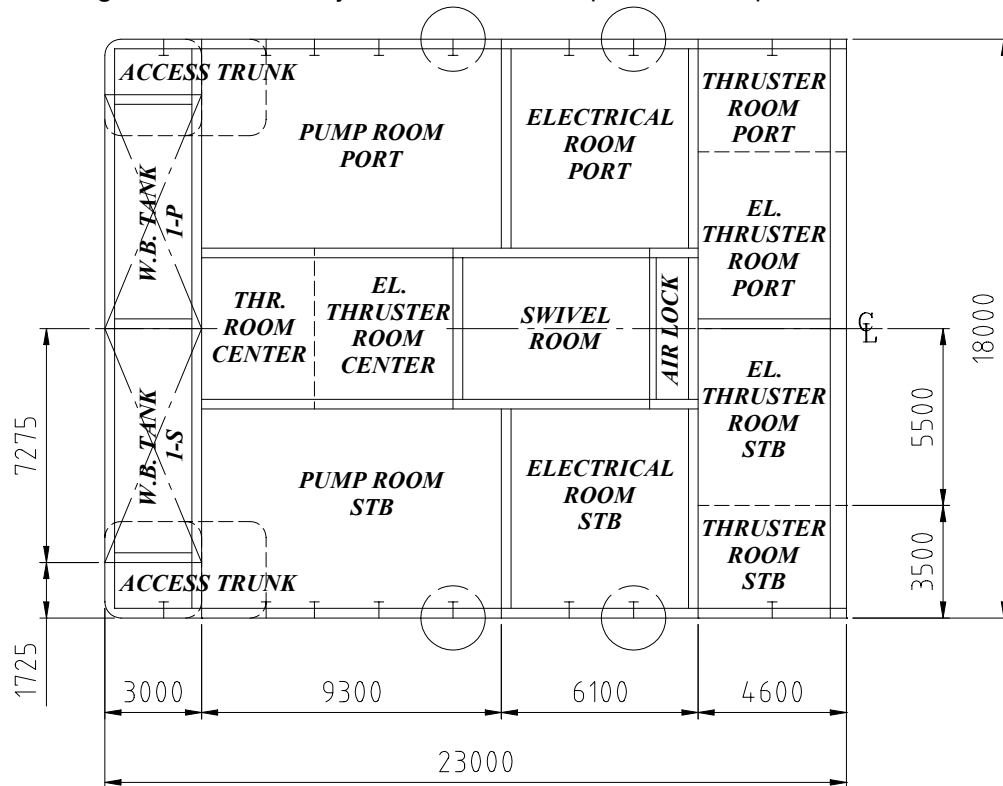

Figure 3 - General Arrangement

General Arrangement

The general arrangement reflects the high level of redundancy that has been put into the DP-Terminal design. All rooms and systems have been duplicated, except from the swivel room.



PLAN

FLOOR 700 ABOVE BASE LINE

Figure 4 - General floor plan

5 Integrated Control System

The integrated control system will make it possible to operate the DP-Terminal unit from the OCC (Operation Control Centre) on the FPSO.

The system is a completely integrated computer based system for safe operation.

The following systems are integrated:

- Machinery systems
- Navigational systems
- Position keeping system (DP-System)
- CCTV system
- Fire and gas systems
- Fire extinction systems
- Emergency shut-down systems
- Other systems related to safe operation of the DP-Terminal

The Integrated Control System (ICS) is based on a dual network system that enables all relevant data to be available to all systems within the integrated system. The complete system will be approved and certified by the classification society for this vessel.

All essential systems integrated in the ICS will be mutually independent, i.e. no single failure in any system will influence on other systems.

Sufficient instrumentation, alarms and control equipment for safe operation of the DP-Terminal unit are included.



Figure 5 - Typical DP-Terminal OCC

5.1 Machinery Systems

Alarm systems, automatic control systems and safety shutdown systems for different machinery systems will be integrated with the ICS.

Alarms for reliable and necessary monitoring and operation of the machinery systems will be provided. Instrumentation will be of known and well-proven technology.

5.2 Navigational Systems

Relevant navigational equipment will be installed and integrated with the ICS according to relevant classification rules for this application. The navigational systems are to give reliable navigational data for the position keeping system and operator of the DP-Terminal unit.

5.3 Dynamic Positioning (DP) System

A fully redundant positioning system (DP-System) will be provided to ensure that position monitoring can be carried out throughout all phases of tanker operation and in the specified environmental condition.

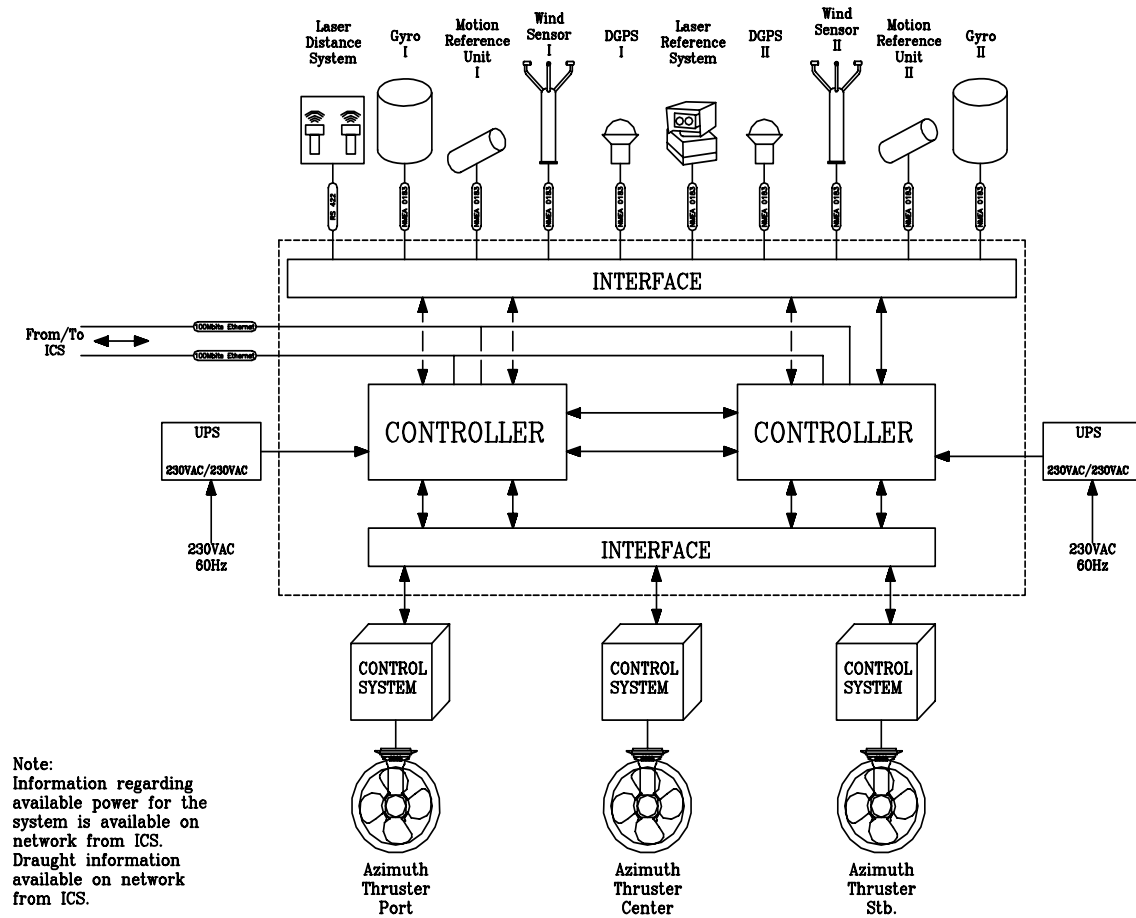

Figure 6 - Principle DP-System

The position system controller and measuring system comprise the following components and subsystems:

- Manual thruster controls
- Joystick thruster controls
- Automatic thruster controls
- Position reference systems
- Sensor systems
- Interface equipment
- Display unit
- Power supplies

5.4 CCTV System

The DP-Terminal will be equipped with necessary cameras for good overview of the DP-Terminal unit, during docking operation. The CCTV system will be integrated in the ICS.

5.5 Safety Systems

Safety systems will be integrated with the ICS.

The safety system comprises:

- Fire and Gas systems
- Fire extinction systems
- Emergency shut-down systems
- O₂ measuring system
- Room pressurisation control system

These systems will ensure the protection of personnel, environment, installation and equipment from accidental and/or uncontrolled hydrocarbon leakage's, and detect and extinguish fires. They will also reduce the effects and minimize the consequences of hydrocarbon leaks and the risk of ignition.

The ESD system shall be integrated in the FPSO ESD system.

5.6 Operation Command Centre (OCC)

The DP-Terminal will be controlled and operated from the Operation Command Centre, a dedicated operator station equipped with monitors, function buttons, joysticks, etc. A typical OCC is shown on Figure 5.

For full redundancy two operator stations will be supplied. From the OCC the operator will have full access to all DP-Terminal systems, sensors and diagnostics, in addition to a number of camera views. A possible solution is shown on Figure 7 below.



Figure 7 - HiLoad Dual Operation Command Centre

6 Operation Description

6.1 Operation Sector

The DP-Terminal operation sector will be decided based upon the following input:

- FPSO excursion
- FPSO mooring system
- Distance between DP-Terminal and FPSO
- DP-Terminal position keeping capabilities
- Flexible riser configuration, length, loads
- Environmental conditions (current and wind)
- Other field structures or equipment
- Safety considerations

A typical operation sector is shown in Figure 8 below. Actual dimensions will be decided based on the above.

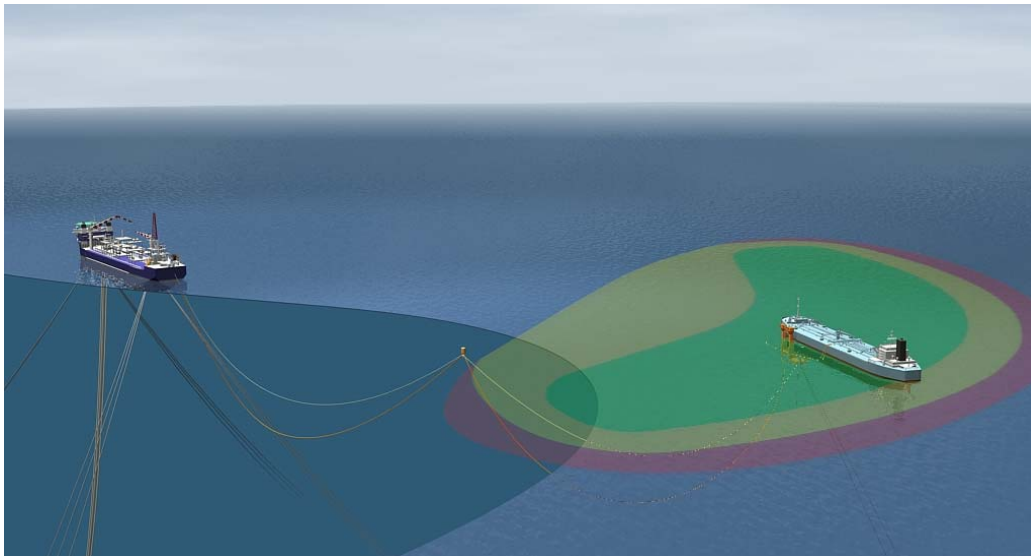

Figure 8 Typical HiLoad operation sector

6.2 Tanker Approach

As the tanker is approaching, the DP-Terminal operator will calculate the optimum mating coordinates with the corresponding heading based on the latest current, wind and wave information. He will inform the tanker master, which will bring the tanker into position with a defined approach route.

The DP-Terminal is monitoring the tanker approach, and will position itself at safe distance from the agreed mating point.

A mooring master will be transferred to the tanker in good time before arriving the meeting point, bringing with him a “docking kit” consisting of:

- ESD telemetry box
- Reflective tape
- Portable UHF radio

The mooring master shall remain onboard the tanker throughout the loading operation, staying in close contact with the tanker master and the DP-Terminal operator.

As the tanker is going dead slow, and finally stopping, the DP-Terminal operator will simultaneously move the DP-Terminal towards the bow of the tanker. A laser reference system will identify the docking position on the tanker using the reflective tape.

6.3 Docking

During the final approach, an “auto-alignment” function on the DP-Terminal will be activated. This function will make sure that the DP-Terminal will maintain correct heading relative to the tanker, simplifying the operator’s task.

With the DP-Terminal in the correct longitudinal position, it is moved towards the side of the tanker. Once the tower fenders will get in touch with the hull side, the deballasting will start. The thrusters will maintain a constant thrust towards the tanker side during deballasting to make sure that the DP-Terminal stays in position.



Figure 9 - DP-Terminal approaching the tanker side

The next part of the DP-Terminal getting in touch with the tanker is the impact fenders on the pontoon. As the deballasting continues, the impact fenders are gradually compressed, and the Attachment system seals and fenders will get in contact with the hull bottom.

By engaging the attachment system, the DP-Terminal will be “locked” to the tanker with several thousand tons of clamping force, making sure that it will not come loose during operation.

Once the attachment system has been activated, the DP system on the DP-Terminal will take control of the tanker position keeping.

6.4 Loading Hose Connection

With the DP-Terminal connected to the tanker, and the position keeping system activated, the loading hose connection can commence. The DP-Terminal is equipped with features so this operation can be carried out on deck level on the tanker, i.e. no assisting vessel required.

6.5 Loading

The DP-Terminal will maintain the position keeping for the tanker during the loading operation. A typical requirement when loading from an offshore storage is 1.000.000 bbls/24h.

If the weather conditions should change during the loading period, it may be necessary to move the mean position due to heading changes for the tanker. The mean position will be located so that the tanker is free to steam forward, or drift backwards without any danger of hitting other structures.

A typical operation sector is shown in Figure 8.

6.6 Undocking

Undocking will be done as a reversed docking operation. The loading hose will be disconnected from the midship manifold, and reeled up on the DP-Terminal. The DP system is deactivated, the attachment system is deactivated and the DP-Terminal ballasted to safe draft and moved away from the tanker. The tanker is then free to steam forward, or back out, whatever is considered to be safest.

6.7 Idle Condition

In between loadings, the DP-Terminal will be kept on location by the passive parking system. Only the most necessary systems will be active, as e.g. fire & gas detection, bilge, ventilation, CCTV, etc. A proper visual inspection of critical components as fenders and seals can be done using the cameras in the CCTV system. Any repairs can be carried out if the weather permits the DP-Terminal to be brought to surface.

7 Verification of Position Keeping Capability

To verify that the DP-Terminal together with the attached tanker had the position keeping ability that was desired, Remora Technology started a position keeping verification study in 2002. Marintek was hired in to do the verification work. Kongsberg Simrad participated during the study as technical advisors.

The scope was to perform both numerical simulations with SIMO and model tests in MARINTEK's Ocean Basin. The idea was that the model testing should be carried out subsequently to the numerical simulations in order to benefit from the experiences obtained during simulations, in particular with regard to controller tuning. Moreover, the improved DP software of SIMO was to be used in model tests. The numerical simulations could also be used to simulate weather conditions not possible to test in the model basin due to limitations related to the directions of current, wind and waves.

The simulations and test were performed with a 150.000 DWT tanker offshore Brazil and a 250.000 DWT tanker offshore West Africa. The tests were performed with a simplified model of the DP-Terminal, where 3 azimuth thrusters were modelled as one representative azimuth thruster.

The simulations and test were carried out in April 2002 in the Ocean Basin laboratory at Marintek.

7.1 Weather Vaning and Operational Philosophy

The DP-Terminal will connect to the Bow Area of the tanker, in the same area as a Mooring Turret normally is located. When the tanker has been connected to the DP-Terminal, it will be free to weathervane around the DP-Terminal Centre, and will take on a mean heading according to prevailing environmental forces.

Because the DP-Terminal is equipped with Thrusters, many of the same features as for a DP tanker will be obtained. Position Reference Systems will constantly measure offsets and velocities, with input to the Position Keeping Control System. Thrust can therefore be applied in the right direction at an early stage, to limit the offset and to bring the tanker back to "Mean Position" in a controlled way.

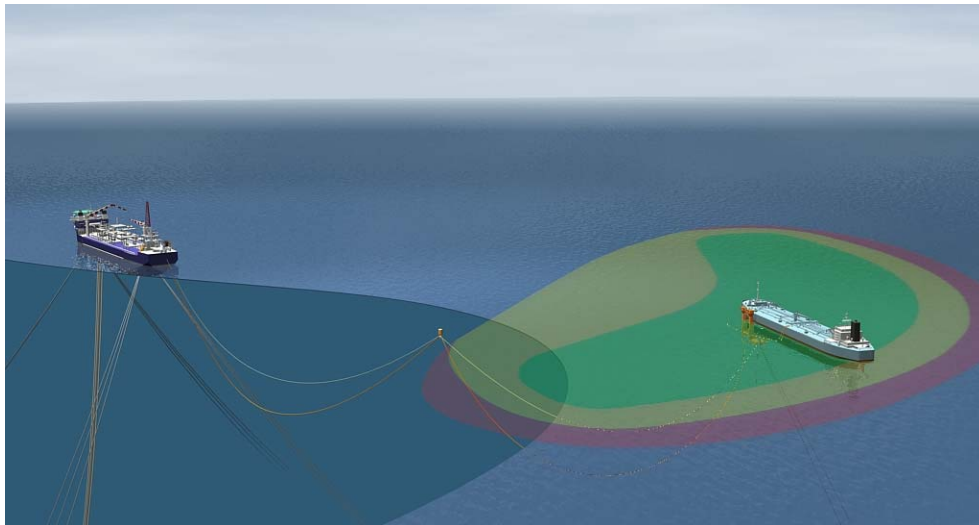

Figure 10 Typical HiLoad operation sector

Since the DP-Terminal position is not restricted by a rigid mooring system, the DP-Terminal is relatively free to operate within a relatively large operating area, ref. Figure 10.

The green area indicates the safe operation area, where no excessive loads are introduced to the risers and umbilicals. If the DP-Terminal and tanker drift into the yellow area, an Emergency Shut-Down I will be initiated automatically stopping the export pumps and closing the crude line valves. If the DP-Terminal and the tanker reach the red area, an ESD II shall be activated, disconnecting the DP-Terminal from the tanker.

Position Keeping Loads

The position keeping with the DP-Terminal is based on letting the tanker weather vane around the DP-Terminal centre. The resulting thrust force and -direction will be governed by the various environmental loads on the tanker, as illustrated in Figure 11.

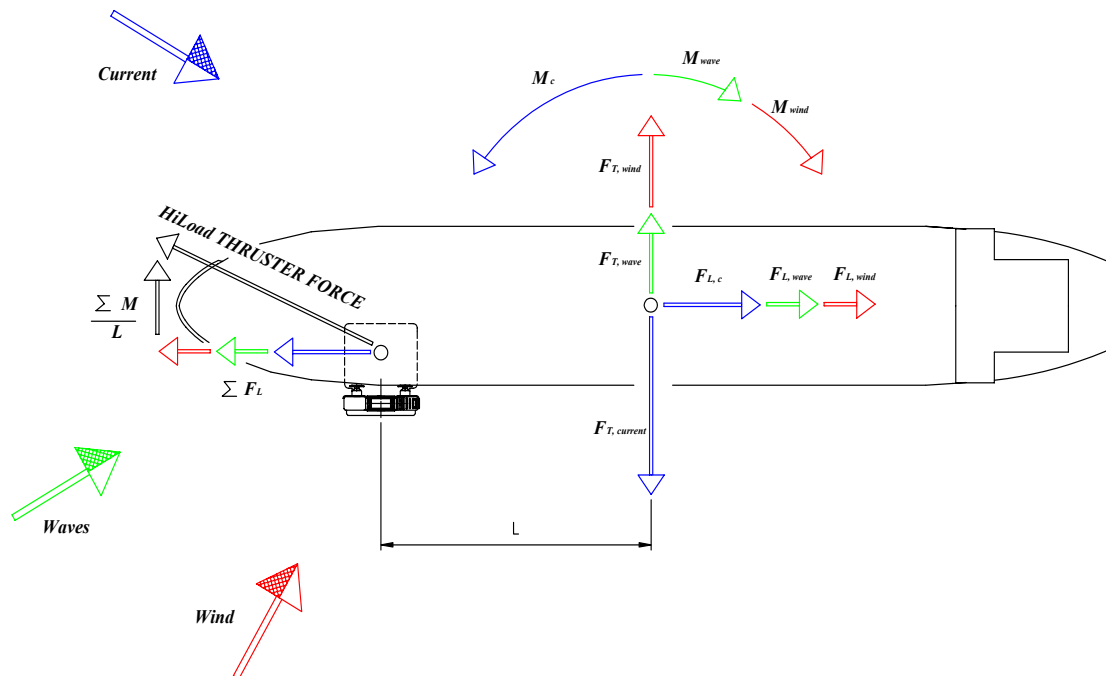

Figure 11 – Principle Resulting thruster force and direction

Traditional DP will control the vessel's motion in three horizontal degrees of freedom: surge, sway and yaw. This requires thrusters at the bow and stern to be able to control the heading. Thus for offloading to standard tankers connected to a HiLoad, there is no need for heading control and this can be neglected. This results in a significant reduction in power consumption, due to that you do not need any thruster force to produce the yaw moment. The DP-Terminal application can hence be able to keep a VLCC in position by use of limited thruster force. This would not be practical with a DP system with heading control that would have required significant more power for a tanker of this size.

The DP regulator used during the tests was modified to only control the vessel motions in two horizontal degrees of freedom i.e. neglecting heading control

The operation of the HiLoad will combine the best features of a weather vaning Turret Moored Vessel with those of a Dynamically Positioned (DP) Vessel.

For the numerical simulation and model test the DP regulator used a combination of proportional action and derivate action (PD regulator). There was a position error since the integrator was not implemented in the regulator. Hence the performance of the control system without integrator was found by subtracting the mean position error from the results. This has been done in the results presentation for all tests.

7.2 Numerical Simulation Study

General

The numerical simulations were performed with the software SIMO, a time domain simulation program developed by Marintek.

The purpose of the work was to study the positioning ability of the DP-Terminal with tankers of various sizes connected. Tankers of three sizes were used – 80.000, 150.000 and 250.000 DWT.

The numerical model for the tanker simulated with SIMO was established by scaling one of MARINTEK's existing numerical tanker models. The data includes wind force coefficients, current force coefficients, wave-to-motion transfer functions and wave-drift coefficients. The same basic model was used for the three ship sizes, only scaled according to their length, using the principle of Froude scaling. The models used did not include the effect of the attached DP-Terminal. It was assumed that neglecting the DP-Terminal would not cause any significant errors, and therefore assumed to be acceptable.

The simulation with SIMO counted twelve cases. Prior to the model testing, seven of the twelve cases to be simulated, were completed prior to the model test. The five remaining simulations were to be carried out after the model tests. The model tests showed significant discrepancy compared to the SIMO results. The differences were found to be due to the current forces acting on the DP-Terminal attached to the tanker, which was higher than calculated with only the bare hull. Using the model test results the original current force coefficients in SIMO were then modified. The seven SIMO simulations that had been carried out were redone with the modified current data.

A check of the wind forces was also done and seemed to be in satisfactory concordance with the physical model compared to the current force model.

SIMO simulation was done with twelve weather conditions representing the climate on the coast of Brazil, the Gulf of Mexico and West Africa. The particulars of the weather conditions are summarized in Table 1 –Case Description of SIMO analysis.

Case	Tanker size DWT	Env. identity	Wave				Wind		Current		Max Thrust (kN)
			Hs (m)	Tp (s)	γ	dir. (deg.)	speed (m/s)	dir. (deg.)	speed (m/s)	dir. (deg.)	
1	150,000	BR-1	4.8	13.0	2.5	270	16.0	180	0.93	180	1000
2	150,000	BR-2	2.5	8.5	2.5	270	7.4	270	1.5	180	2000
3	150,000	BR-1	4.8	13.0	2.5	270	16.0	180	0.93	180	1200
4	150,000	BR-1	4.8	13.0	2.5	180	16.0	180	0.93	180	2000
5	80,000	GOM-1	4.5	9.2	3.0	270	15.0	210	1.0	180	2000
6	80,000	GOM-2	4.5	9.2	3.0	180	15.0	180	1.0	180	2000
7	80,000	GOM-3	4.5	9.2	3.0	270	15.0	210	0.5	180	2000
8	250,000	WA-1	3.1	12.2	6.0	270	8.0	270	0.0	-	2000
9	250,000	WA-2	2.3	13.3	6.0	270	17.3	180	0.65	180	2000
10	250,000	WA-3	2.3	13.3	6.0	270	17.3	210	0.65	180	2000
11	250,000	WA-4	3.1	12.2	6.0	270	17.3	180	0.0	-	2000
12	250,000	WA-5	2.3	13.3	6.0	180	17.3	180	0.65	180	2000

Table 1 –Case Description of SIMO analysis

SIMO Analysis Results

The general impression of the simulated cases was that the DP-Terminal with the chosen principle of control will be able to keep the tankers well inside a circle of 50 m radius.

Conclusion - SIMO Analysis

The positioning principle of the DP-Terminal is unorthodox in that all the thrusters are located on the DP-Terminal unit. The spacing between the thrusters is consequently small. As a consequence it is not possible to control the tanker's heading.

A control principle in which heading was disregarded was modeled in SIMO. The positioning requirements were comparatively slack, so that low controller gains could be used.

Comparison with model tests showed that the longitudinal current force on the tankers was higher than predicted theoretically. This is due to the DP-Terminal unit being attached to the tanker. Based on the model test experience, it was attempted to correct the current coefficients. To obtain good results, however, wind tunnel tests were recommended to be carried out with the DP-Terminal connected to the ship. This is important to get a correct mean heading in the simulation.

Data plot from the WA1-4 SIMO simulations are enclosed in Appendix 1.

7.3 Model Test

General

The model test was carried out on the vessel sizes 150.000DWT and the 250.000DWT, same hull was used with corresponding scale 1:60 and 1:70.

The DP-system used during the test was programmed according to the DP-software in SIMO and with the same control parameters.

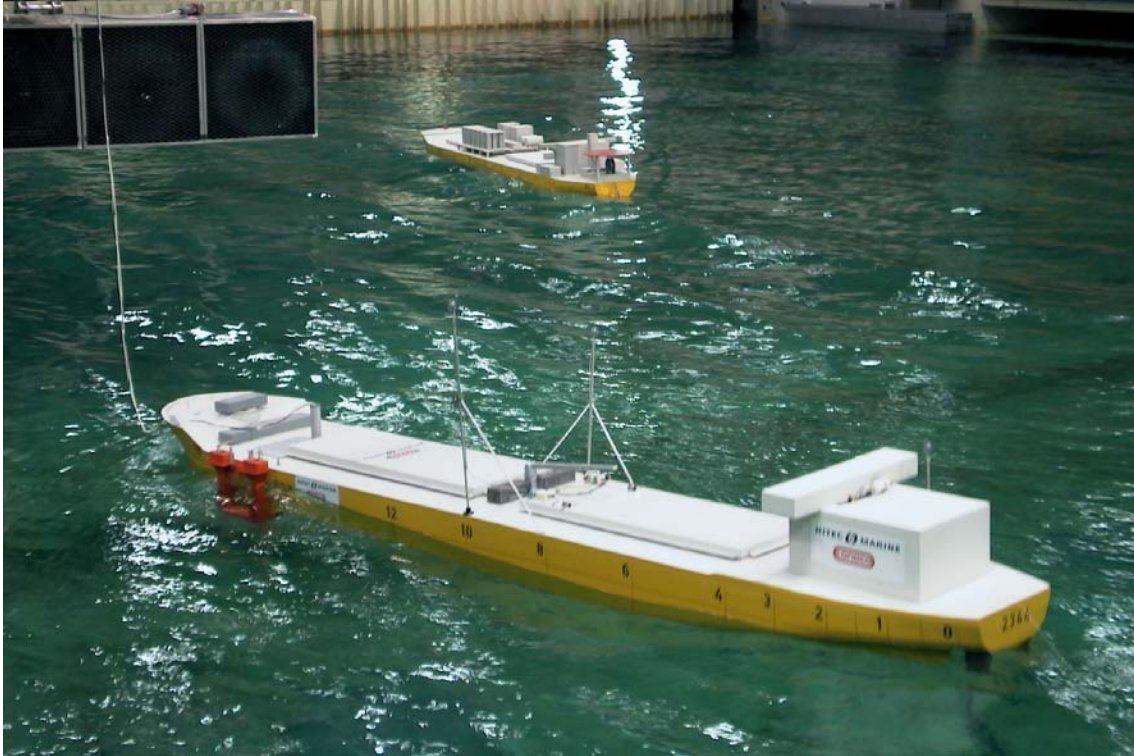

Figure 12 – Snap shot from the test in Ocean Basin Lab

The model test was done with twelve weather conditions representing the climate on the coast of Brazil and West Africa. The particulars of the weather conditions are summarized in Table 2.

Test no.	File head text	Heading deg.	Wave cond.		Cur. C m/s	Wind	
			H _s m	T _p s		W m/s	Dir. deg.
	BRAZIL 150 000 DWT - 1:60						
6010	IRR H4.8 T13.0 C0.93 W16 -90/0/0 BR1 1.5 F1000	-	4.8	13.0	0.93	16.0	0
6020	IRR H2.5 T8.5 C1.5 W7.4 -90/0/-90 BR2 1.5 F2000	-	2.5	8.5	1.5	7.4	-90
6031	IRR H2.5 T8.5 C1.5 W7.4 -90/0/-30 BR3 1.5 F1200	-	2.5	8.5	1.5	7.4	-30
	WEST OF AFRICA 250 000 DWT - 1:70						
7010	IRR H3.1 T12.2 C0 W8 -90/-90 WA1 2.5 F2000	-	3.1	12.2	0	8.0	-90
7020	IRR H2.3 T13.3 C.65 W17.3 -90/0/0 WA2 2.5 F2000	-	2.3	13.3	0.65	17.3	0
7030	IRR H2.3 T13.3 C.65 W17.3 -90/0/-30 WA3 2.5 F2000	-	2.3	13.3	0.65	17.3	-30
7040	IRR H3.1 T12.2 C0 W8 -90/-0 WA4 2.5 F2000	-	3.1	12.2	0	8.0	0

-90/0/-90 = Wave dir./Current dir./Wind dir.

Table 2 – Test Program for Brazil and West Africa Coast

Model Test Results

The results from the DP-tests for WA1-4 are summarized in the table below.

DWT	Test no.	Cond	Thrust (kN)		Thrust hdg. (deg)		Yaw (deg)		R-HiLoad (m)	
			Mean	St.dev	Mean	St.dev	Mean	St.dev	Max.	St.dev
250000	7010	WA1	229	59	-20.0	13.3	-82.0	4.0	13.3	2.8
	7020	WA2	766	49	4.5	8.2	-9.0	2.5	14.4	3.0
	7030	WA3	710	43	2.0	8.2	-17.4	2.0	19.0	3.5
	7040	WA4	615	149	-24.4	15.5	-27.1	6.4	37.2	6.7

Table 3 – Summarized results for WA1-4

It was demonstrated that the DP-Terminal managed to keep both the 150.000 DWT tanker and the 250.000 DWT tanker in position in a very satisfactory way and well within a circle with radius of 50m.

For the tested conditions with the 150.000 DWT tanker offshore Brazil, the maximum offset was about 32 m, with a standard deviation of about 7 m.

For the tested conditions with the 250.000 DWT tanker offshore West Africa, the maximum offset was about 37 m, with a standard deviation of about 7 m.

Data plot from the WA1-4 Model tests are enclosed in Appendix 2.

Conclusion – Model Test

Based on the model tests results, the following conclusions can be drawn:

- During the tests, it was demonstrated that the DP-Terminal system managed to keep both the 150.000 DWT tanker offshore Brazil and the 250.000 DWT tanker offshore West Africa in position very satisfactorily. The maximum horizontal offset measured was well within a circle with a radius of 50m.
- For the tested conditions with the 150.000 DWT tanker offshore Brazil, the maximum offset was about 32m, with a standard deviation of about 7 m.
- For the tested conditions with the 250.000 DWT tanker offshore West Africa, the maximum offset was about 37 m, with a standard deviation of about 7 m.
- For the additional current tests with a current speed corresponding to 1.5 m/s the tests showed that the longitudinal current force increased higher than anticipated with HiLoad attached to the hull. A significant portion of this added longitudinal force was assumed to be due to the scale effect.
- A thrust loss of about 20% was derived from the additional tests in current with a current speed corresponding to 1.5 m/s. This thrust loss depends on the operating conditions of the thruster. Based on earlier model tests and full scale experiments the thrust loss of a thruster operating at full power in an axial current of 1 m/s can be estimated to 10%

7.4 Wind Tunnel Test

General

It was decided to carry out a wind tunnel test at the Laboratory of Danish Maritime Institute (DMI) in Denmark. The wind tunnel test was carried out in October 2002.

As described earlier, the DP-Terminal will give extra drag to the system when it is connected to the tanker because the exposed drag area is increased. In order to determine the correct drag and have an accurate model for numerical simulation, tests were carried out both with and without the DP-Terminal connected to the tanker.

Conclusion - Wind Tunnel Test

The results from the Wind Tunnel Test showed as expected that the current load measured at the DP model test at Marintek was too high.

The results from the wind tunnel test are concluded to be an excellent “tool” in order to calculate and simulate the required thruster force for different environmental conditions. The new current drag coefficients will be implemented in SIMO model in order to run realistic and accurate field specific simulations.



Figure 13 - Test with Helium Bubbles

7.5 Main Conclusion

Main conclusion drawn after the numerical simulation, model test and wind tunnel test are:

- Tests were a success and confirmed that weather vaning with HiLoad performed very well.
- The test showed that HiLoad will be able to keep the attached tanker well within a 50m radius with low power consumption.
- A model for accurate numerical simulation can now be used for field specific simulation.

A APPENDIXES

A.1 DATA PLOT NUMERICAL SIMULATIONS

HiLoad Tanker 1:70
WA-1 Extreme wave

*.
*.

RW	Minimum	Maximum	Mean	Std.dev	Skewness	Kurtosis	Name
7	-2.469	2.670	.7356E-05	1.151	-.1555E-01	2.445	X_HiL_LF(m)
8	-6.658	5.403	-.4490E-04	3.096	-.3138	1.934	Y_HiL_LF(m)
14	-.5678	-.4104	-.5057	.2027E-01	.6640	3.641	Roll_total(deg)
6	81.16	87.97	85.42	1.505	-.3263	2.528	Head_LF(deg)
17	88.60	494.9	220.2	75.02	.8310	3.439	Thrust(kN)
18	6.041	27.83	13.58	3.970	.2089	2.896	Thr_dir(deg)
37	.1136	6.688	2.999	1.383	.2890	2.584	Dist._HiL_LF(m)
38	.1040	359.9	170.0	96.45	.1004	1.510	Ang._HiL_LF(deg)

Data points 5584 - 16384

RW 8 has smallest MIN. and RW 17 has largest MAX.

RW 14 has smallest STD. and RW 38 has largest STD.

New values to Cg, Ch, Ci and Cj. Cg = 8. Ch = 17. Ci = 14. Cj = 38.

HiLoad Tanker 1:70
WA-1 Extreme wave

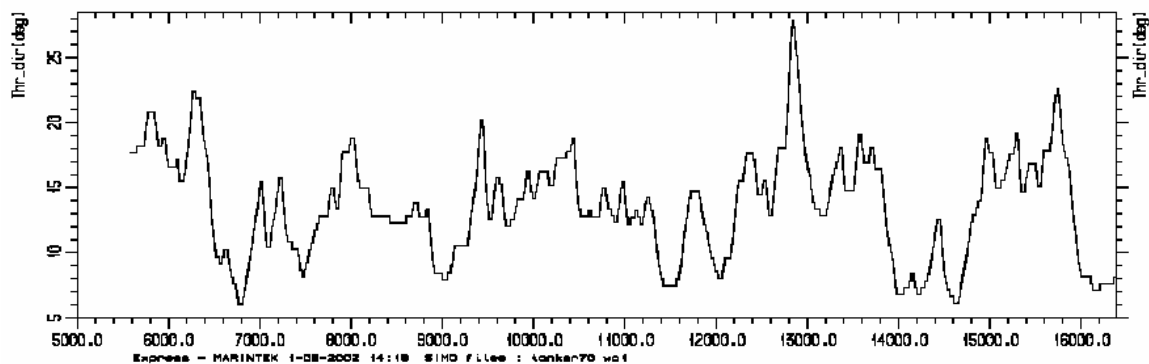
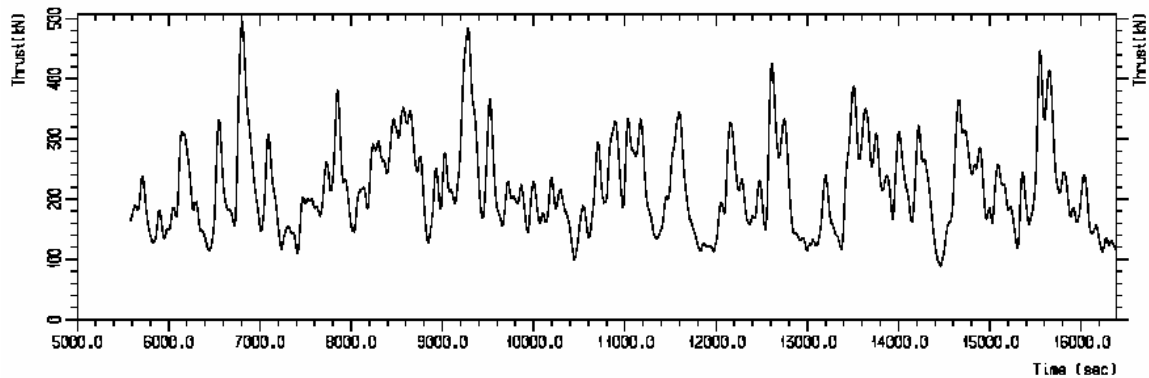

HiLoad Tanker 1:70

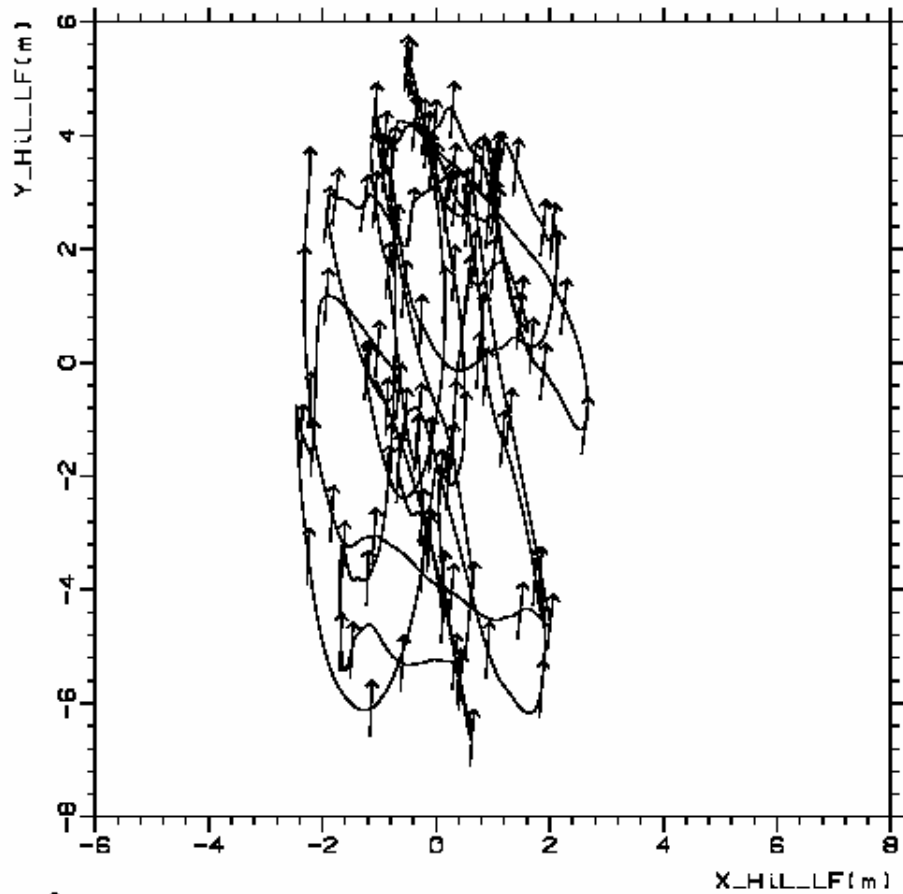

◇ Start position
100.00 sec. between arrows

WA-1 Extreme wave

SINO files : tanker70 wa1
Express - MARINTEK 1-05-2002 14:18

HiLoad Tanker 1:70 *.
 WA-2 Extreme current/wind-I (River-plume) *.

RW	Minimum	Maximum	Mean	Std.dev	Skewness	Kurtosis	Name
7	-6.665	4.045	-.1053E-03	2.357	-.4868	2.821	X_HiL_LF(m)
8	-5.790	5.086	.9285E-05	2.295	-.2223	2.452	Y_HiL_LF(m)
14	-5.5149	.3368	-.1256	.1081	.1550	3.377	Roll_total(deg)
6	13.75	23.55	19.09	2.679	-.3489	1.985	Head_LF(deg)
17	315.8	551.3	422.4	43.67	.3546	3.177	Thrust(kN)
18	-36.63	16.51	-19.82	9.163	.8613	3.444	Thr_dir(deg)
37	.2633E-01	6.671	2.942	1.472	.2498	2.326	Dist_HiL_LF(m)
38	.8322E-01	360.0	178.4	104.8	.2922E-01	1.693	Ang_HiL_LF(deg)

Data points 5584 - 16384

RW 18 has smallest MIN. and RW 17 has largest MAX.

RW 14 has smallest STD. and RW 38 has largest STD.

New values to Cg, Ch, Ci and Cj. Cg = 18. Ch = 17. Ci = 14. Cj = 38.

HiLoad Tanker 1:70
 WA-2 Extreme current/wind-I (River-plume)

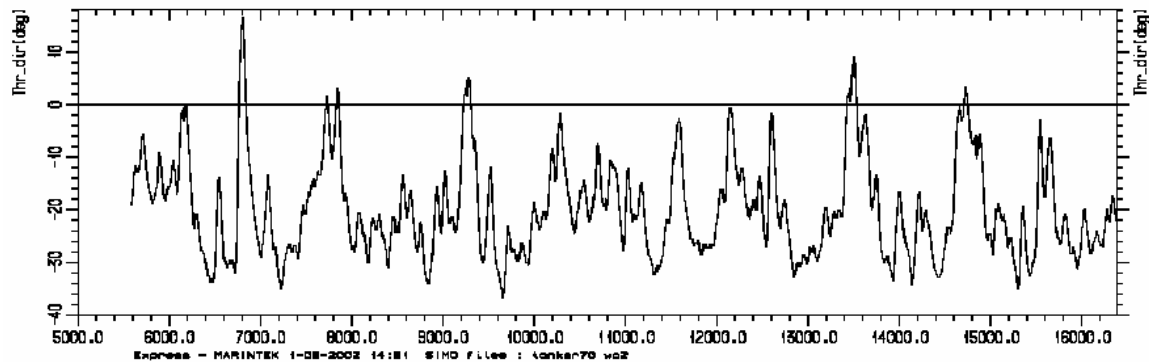
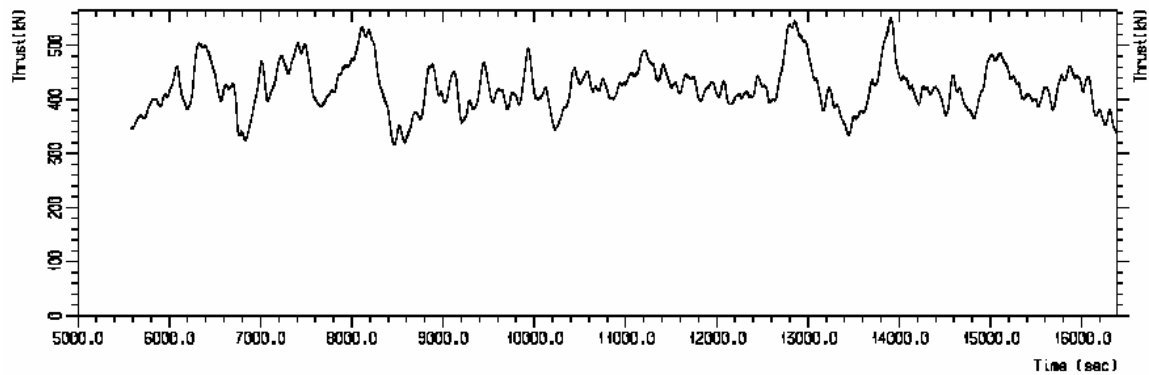

HiLoad Tanker 1:70

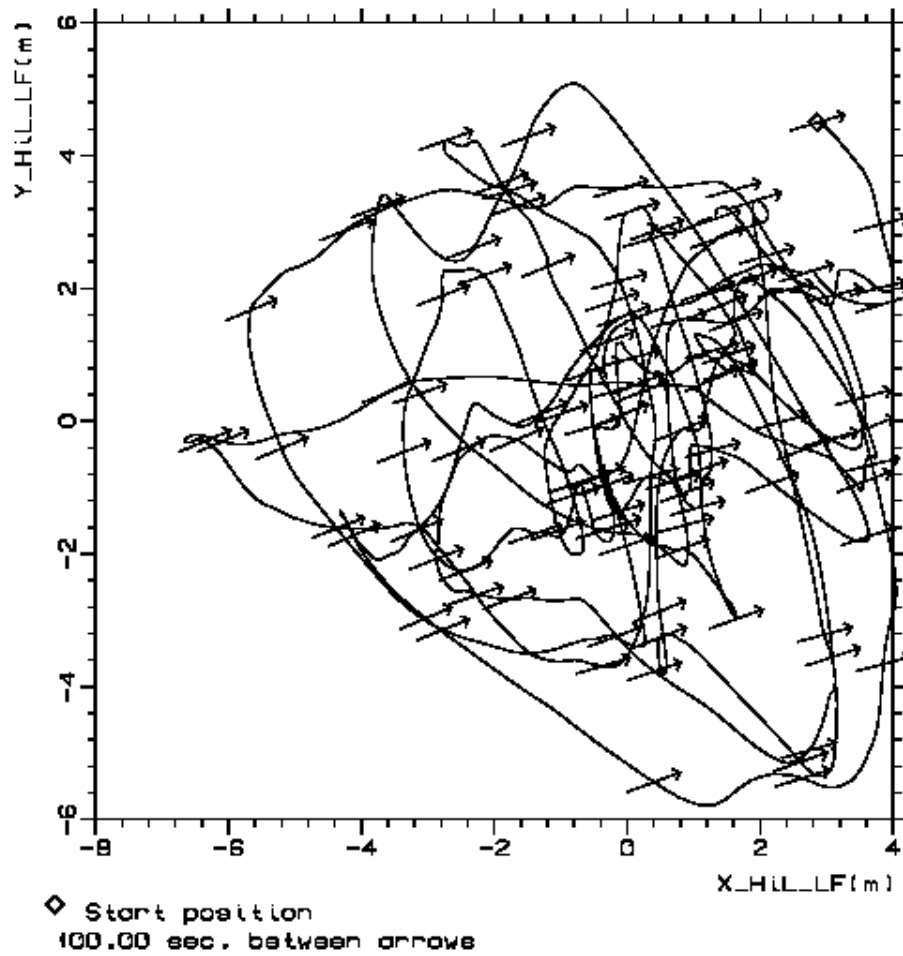

WA-2 Extreme current/wind-1 (River-plume)

SINO files : tanker70 wa2
Express - MARINTEK 1-05-2002 14:51

```

HiLoad Tanker 1:70
WA-3 Extreme current/wind-II

```

RW	Minimum	Maximum	Mean	Std.dev	Skewness	Kurtosis	Name
7	-6.873	4.745	-.1154E-03	2.513	-.1989	2.538	X_HiL_LF(m)
8	-4.869	5.664	-.7641E-05	2.438	.4098E-01	2.024	Y_HiL_LF(m)
14	-.4599	.2341	-.1492	.8927E-01	.1118	3.263	Roll_total(deg)
6	20.28	29.10	25.15	2.177	-.2559	2.322	Head_LF(deg)
17	324.8	538.5	420.4	40.01	.2175	2.993	Thrust(kN)
18	-26.42	20.51	-5.227	9.020	.3473	2.537	Thr_dir(deg)
37	.8026E-02	7.295	3.209	1.399	.1688	2.712	Dist_HiL_LF(m)
38	.3271E-01	359.9	175.3	102.5	-.1978E-01	1.823	Ang_HiL_LF(deg)

Data points 5584 - 16384

RW 18 has smallest MIN. and RW 17 has largest MAX.

RW 14 has smallest STD. and RW 38 has largest STD.

New values to Cg, Ch, Ci and Cj. Cg = 18. Ch = 17. Ci = 14. Cj = 38.

```

HiLoad Tanker 1:70
WA-3 Extreme current/wind-II

```

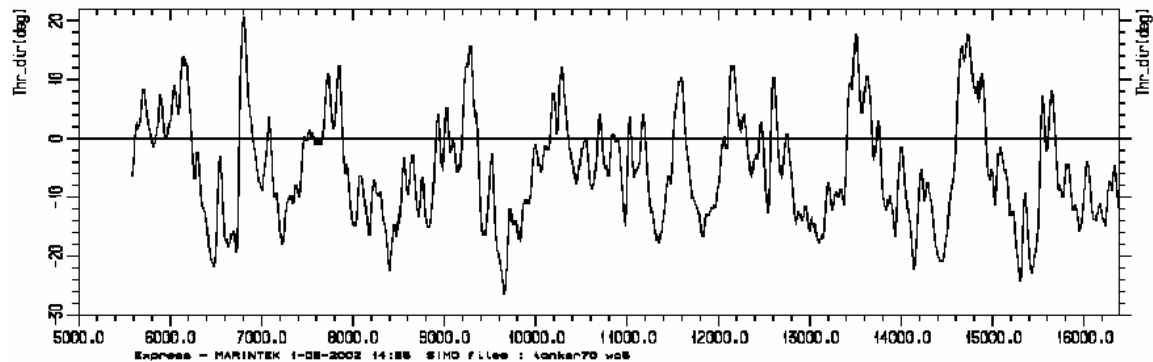
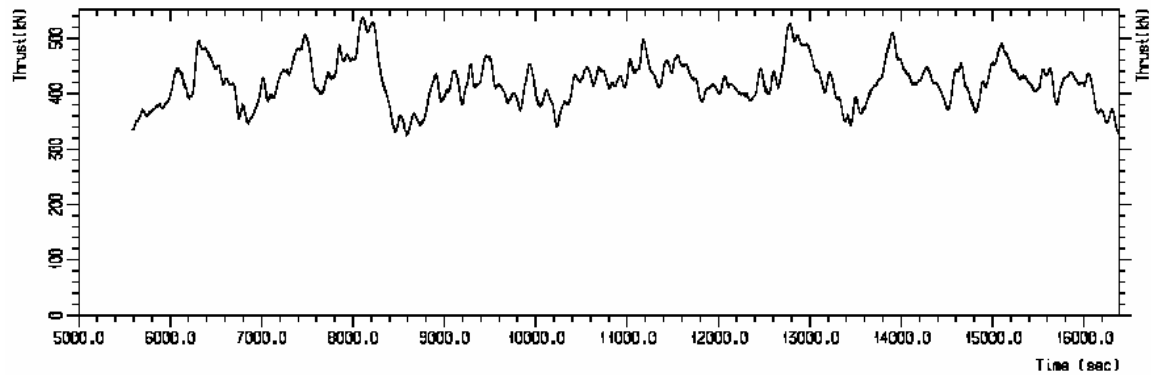

HiLoad Tanker 1:70

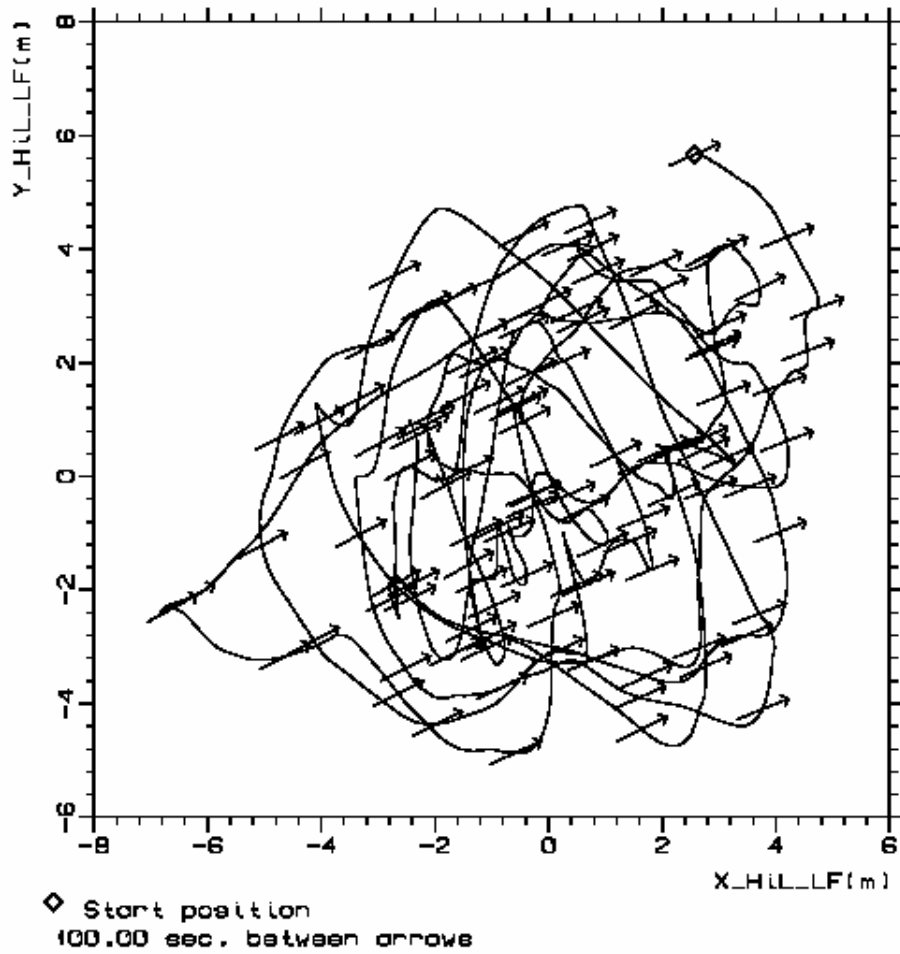

WA-3 Extreme current/wind-11

SINO files : tanker70 wa5
Express - MARINTEK 1-05-2002 14:55

HiLoad Tanker 1:70
WA-4 Extreme wave/wind

*.
*.

RW	Minimum	Maximum	Mean	Std.dev	Skewness	Kurtosis	Name
7	-15.32	15.15	.4042E-04	7.100	-.1128	2.012	X_HiL_LF(m)
8	-24.65	21.23	-.4289E-04	11.37	-.4373E-01	1.942	Y_HiL_LF(m)
14	-.6592	.1480	-.2322	.1150	-.2617	2.862	Roll_total(deg)
6	22.30	57.21	41.08	9.669	-.1146	1.741	Head_LF(deg)
17	270.6	834.6	449.1	106.3	.8018	3.147	Thrust(kN)
18	-17.27	57.29	15.32	14.43	.4194	2.900	Thr_dir(deg)
37	.3975	27.26	12.41	5.070	.3125	2.869	Dist_HiL_LF(m)
38	.1679	360.0	164.7	99.11	.1173	1.621	Ang_HiL_LF(deg)

Data points 5584 - 16384

RW 8 has smallest MIN. and RW 17 has largest MAX.

RW 14 has smallest STD. and RW 17 has largest STD.

New values to Cg, Ch, Ci and Cj. Cg = 8. Ch = 17. Ci = 14. Cj = 17.

HiLoad Tanker 1:70
WA-4 Extreme wave/wind

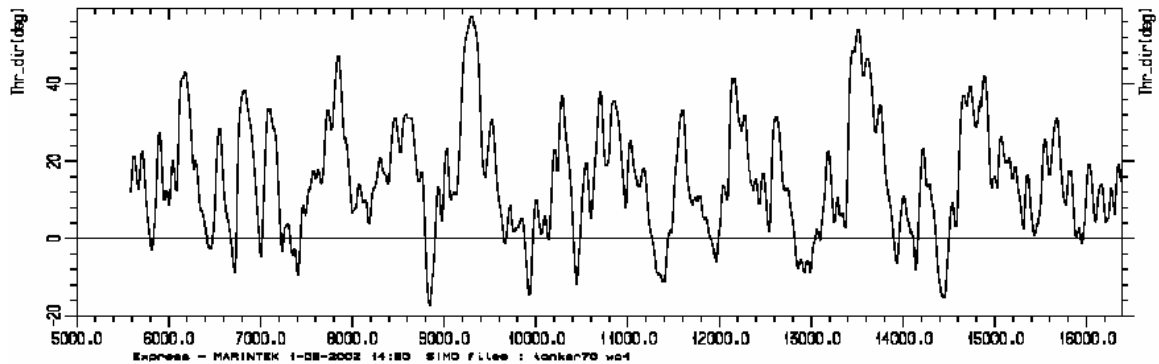
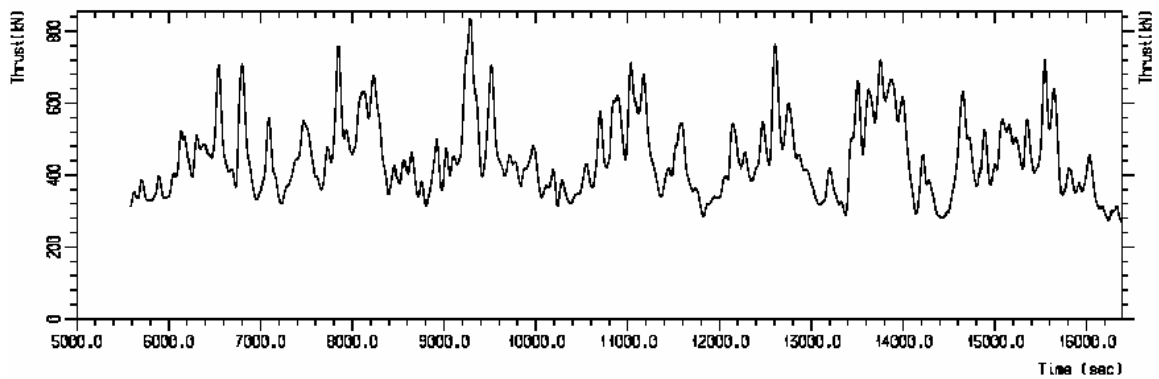

HiLoad Tanker 1:70

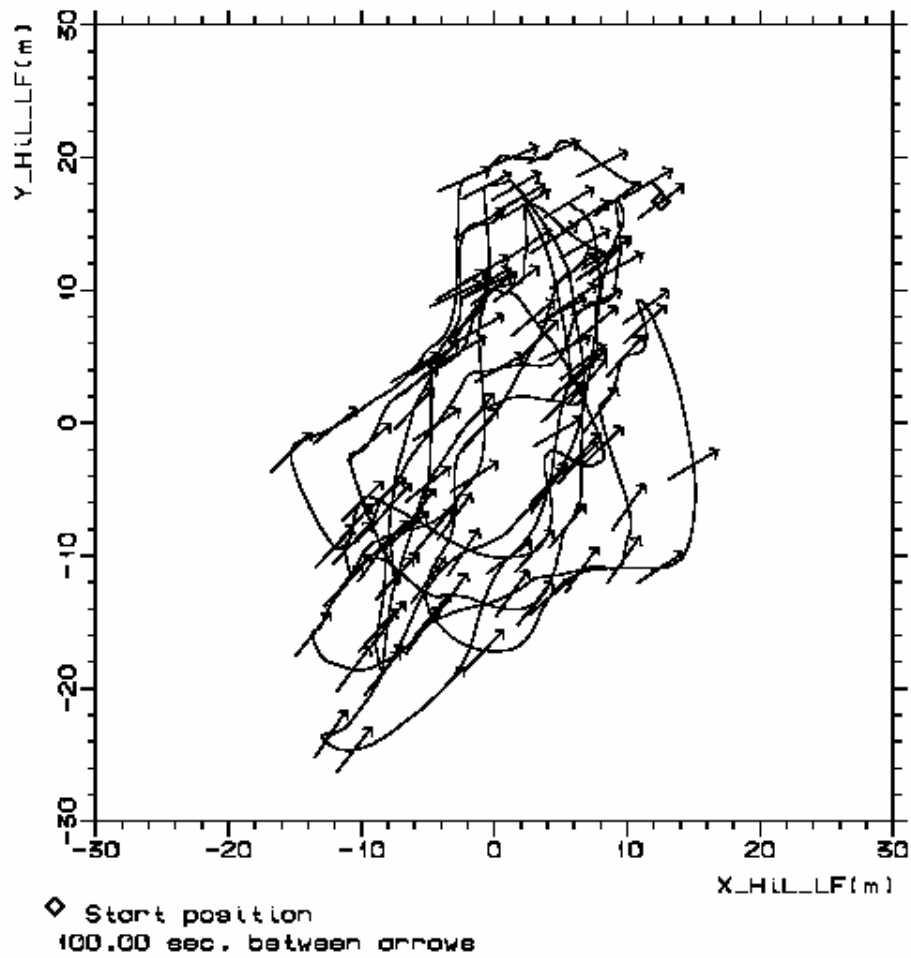

WA-4 Extreme wave/wind

SINO files : tanker70 wa4
Express - MARINTEK 1-05-2002 14:50

HiLoad Tanker 1:70
WA-5 Extreme current/wind

*.
*.

RW	Minimum	Maximum	Mean	Std.dev	Skewness	Kurtosis	Name
7	-4.152	4.026	-.1537E-03	1.764	-.2115	2.392	X_HiL_LF(m)
8	-1.735	1.921	.3062E-04	.9792	.7799E-01	1.934	Y_HiL_LF(m)
14	-.2294E-01	.2100	.8706E-01	.3380E-01	.6117E-01	3.009	Roll_total(deg)
6	-11.43	-8.751	-10.09	.5558	.7975E-01	3.186	Head_LP(deg)
17	420.6	664.9	520.8	43.47	.2413	2.772	Thrust(kN)
18	27.40	33.99	30.79	1.282	.7605E-01	2.512	Thr_dir(deg)
37	.7977E-02	4.476	1.774	.9605	.5768	2.793	Dist._HiL_LF(m)
38	.8837E-01	359.9	165.2	106.5	.1920	1.915	Ang._HiL_LF(deg)

Data points 5584 - 16384

RW 6 has smallest MIN. and RW 17 has largest MAX.

RW 14 has smallest STD. and RW 38 has largest STD.

New values to Cg, Ch, Ci and Cj. Cg = 6. Ch = 17. Ci = 14. Cj = 38.

HiLoad Tanker 1:70
WA-5 Extreme current/wind

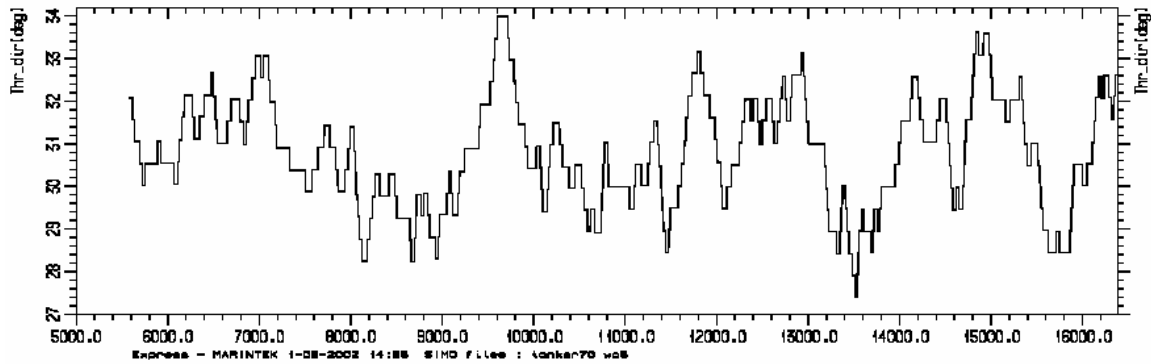
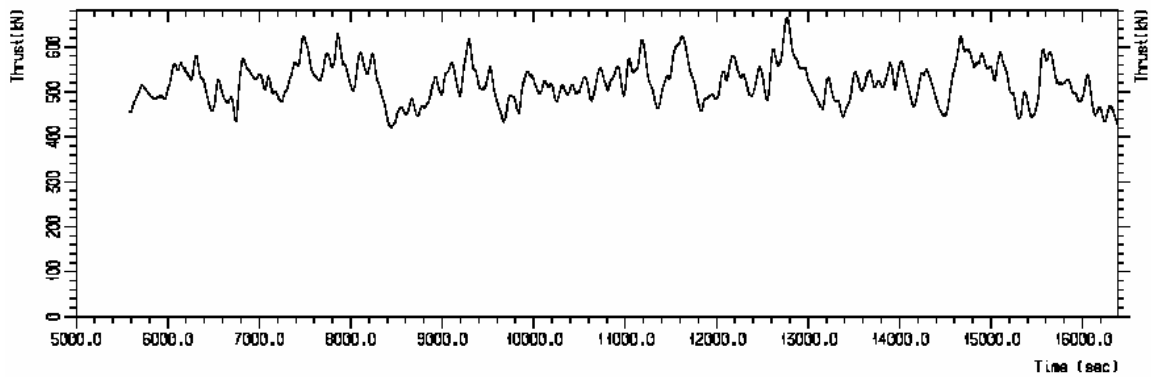

HiLoad Tanker 1:70

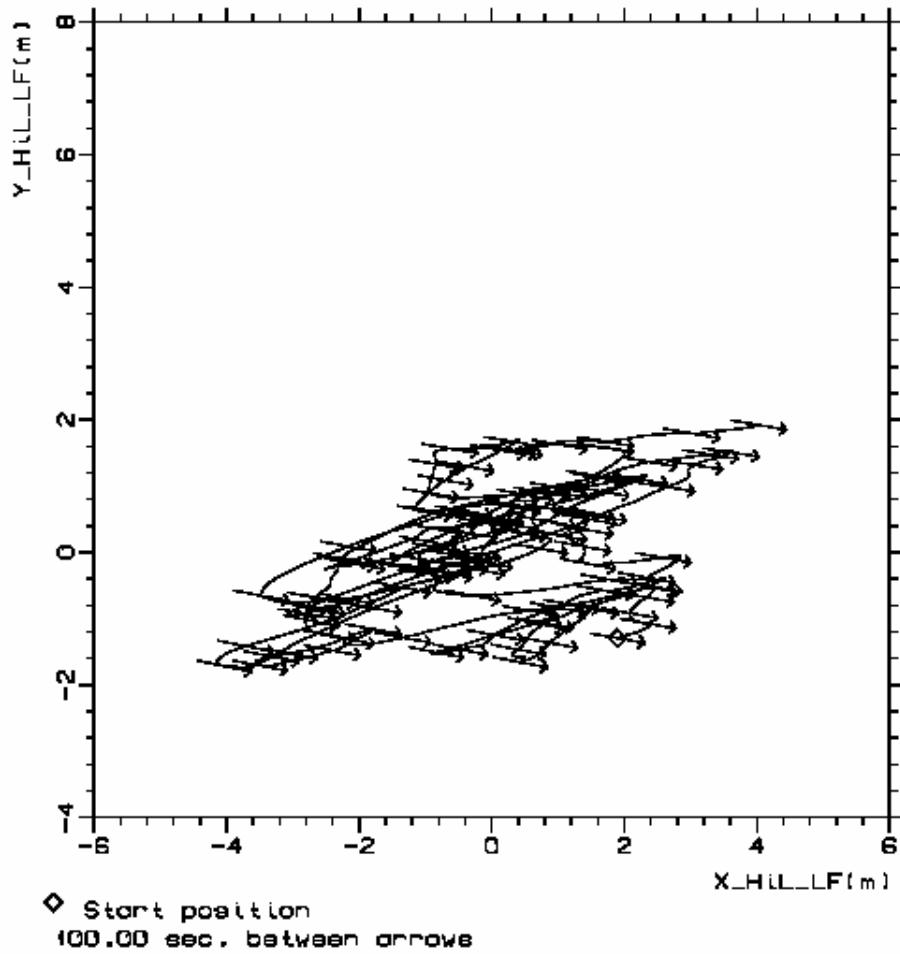

WA-5 Extreme current/wind

BIND files : tanker70 wa5
Express - MARINTEK 1-05-2002 14:55

A.2 DATA PLOT MODEL TEST

Scale	Test	Hs m	Tp s	C m/s	W m/s	Dir deg	Hodetekst
70	7010	3.1	12.2	0	8.0	-90	IRR H3.1 T12.2 C0 W8.0 -90/-/90 WA1 2.4 F2000
70	7020	2.3	13.3	0.65	17.3	0	IRR H2.3 T13.3 C0.65 W17.3 -90/0/0 WA2 2.4 F2000
70	7030	2.3	13.3	0.65	17.3	-30	IRR H2.3 T13.3 C0.65 W17.3 -90/0/-30 WA3 2.4 F2000
70	7040	3.1	12.2	0	8.0	0	IRR H3.1 T12.2 C0 W8.0 -90/-/0 WA4 2.4 F2000

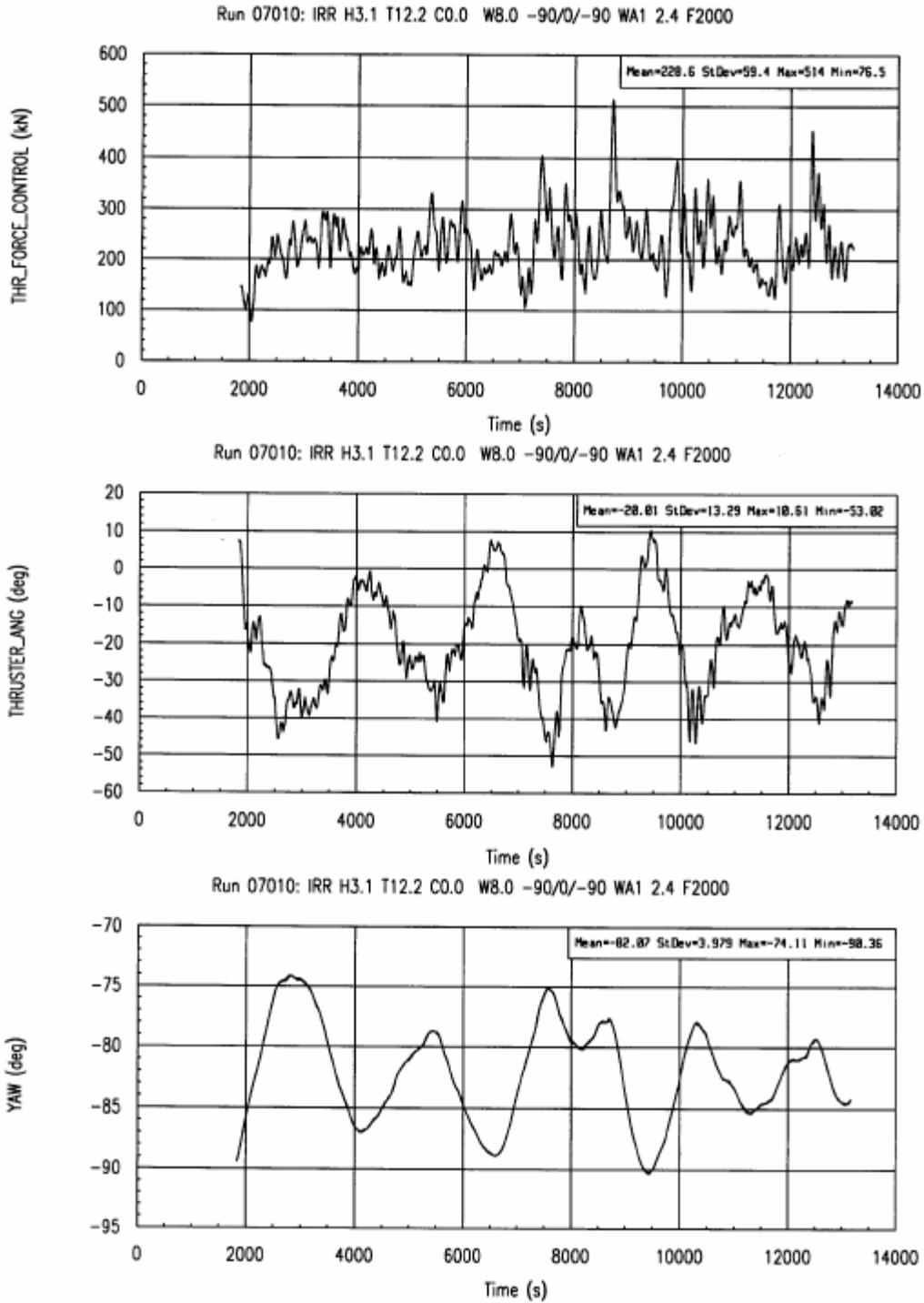

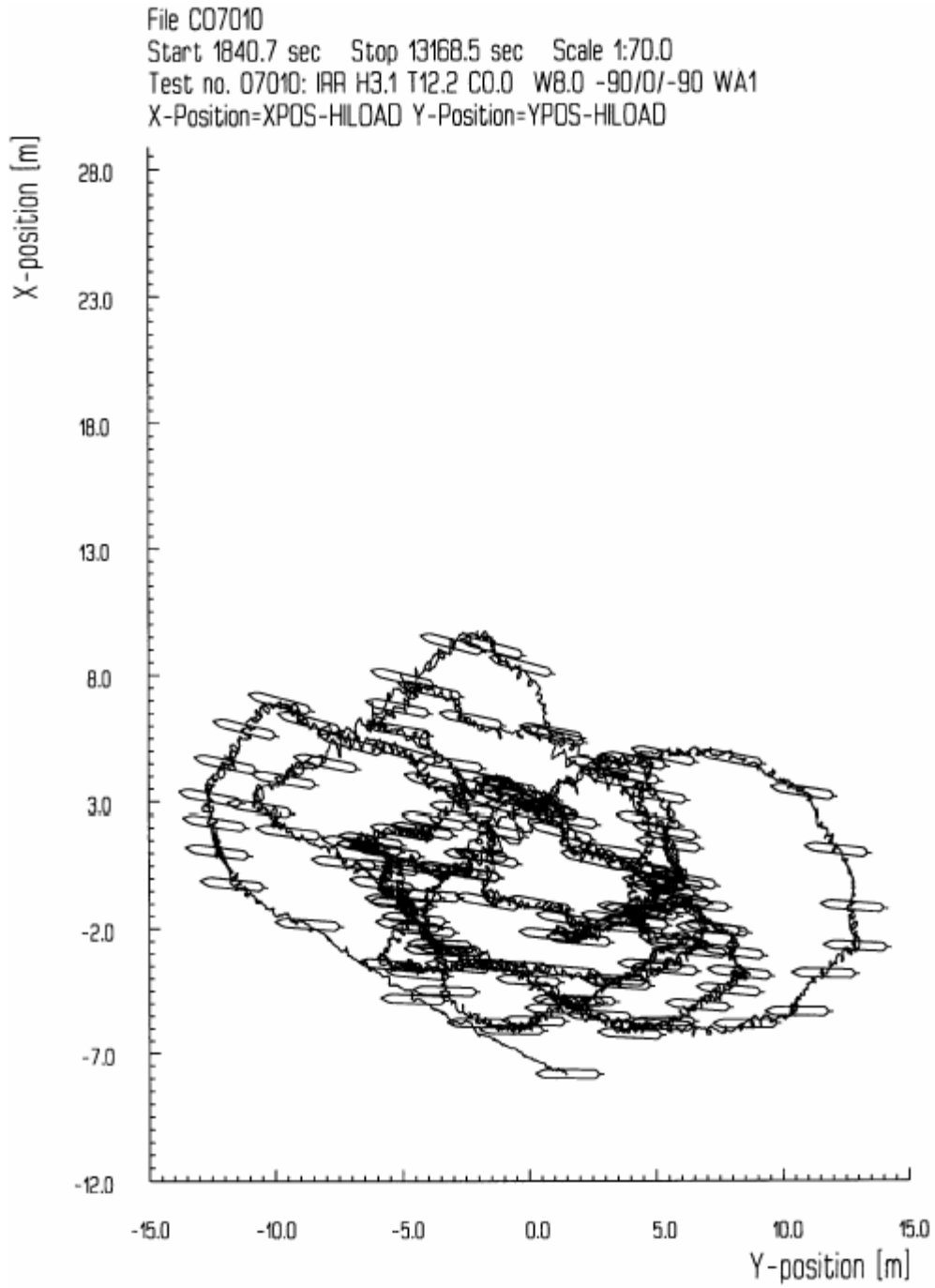

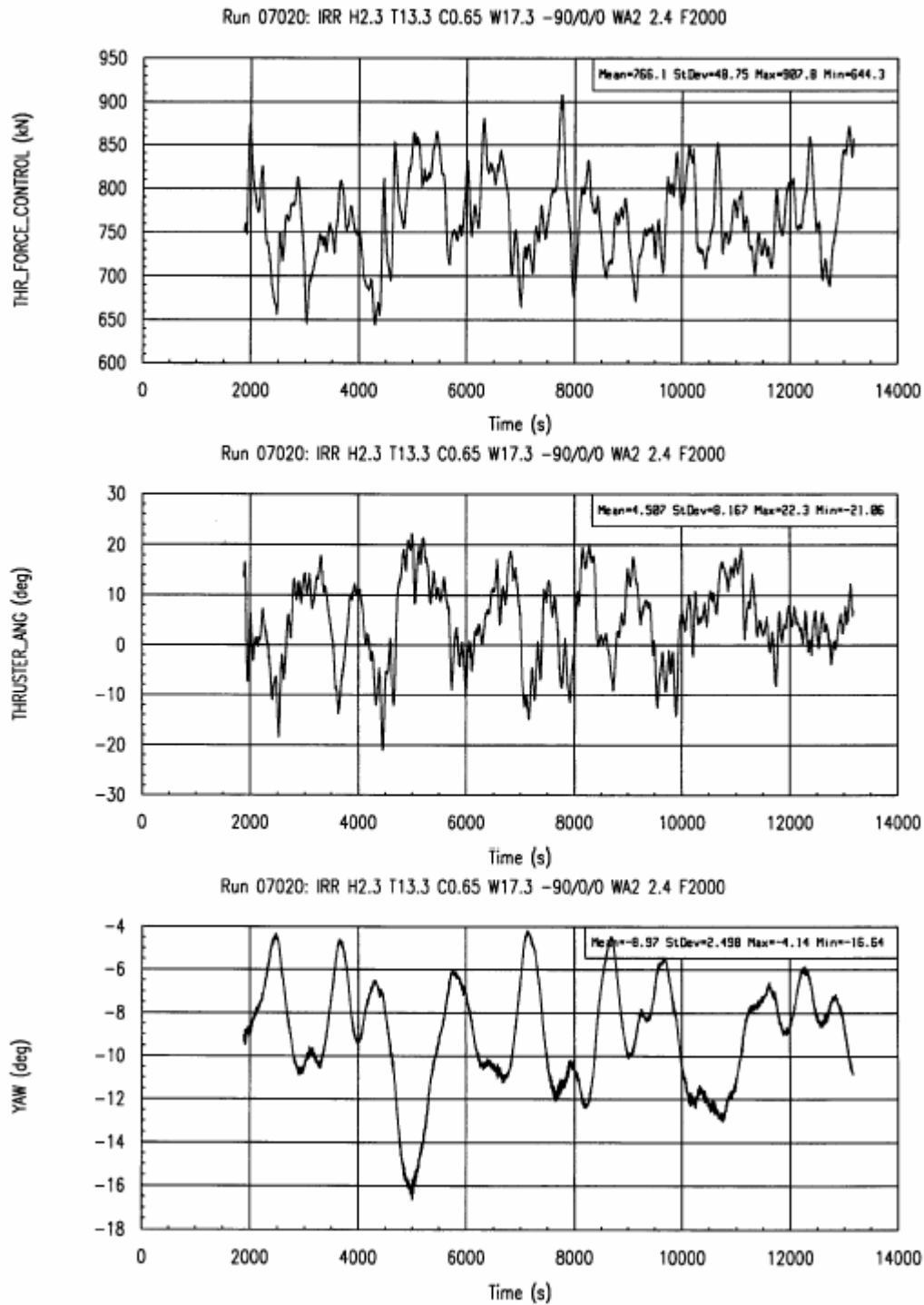

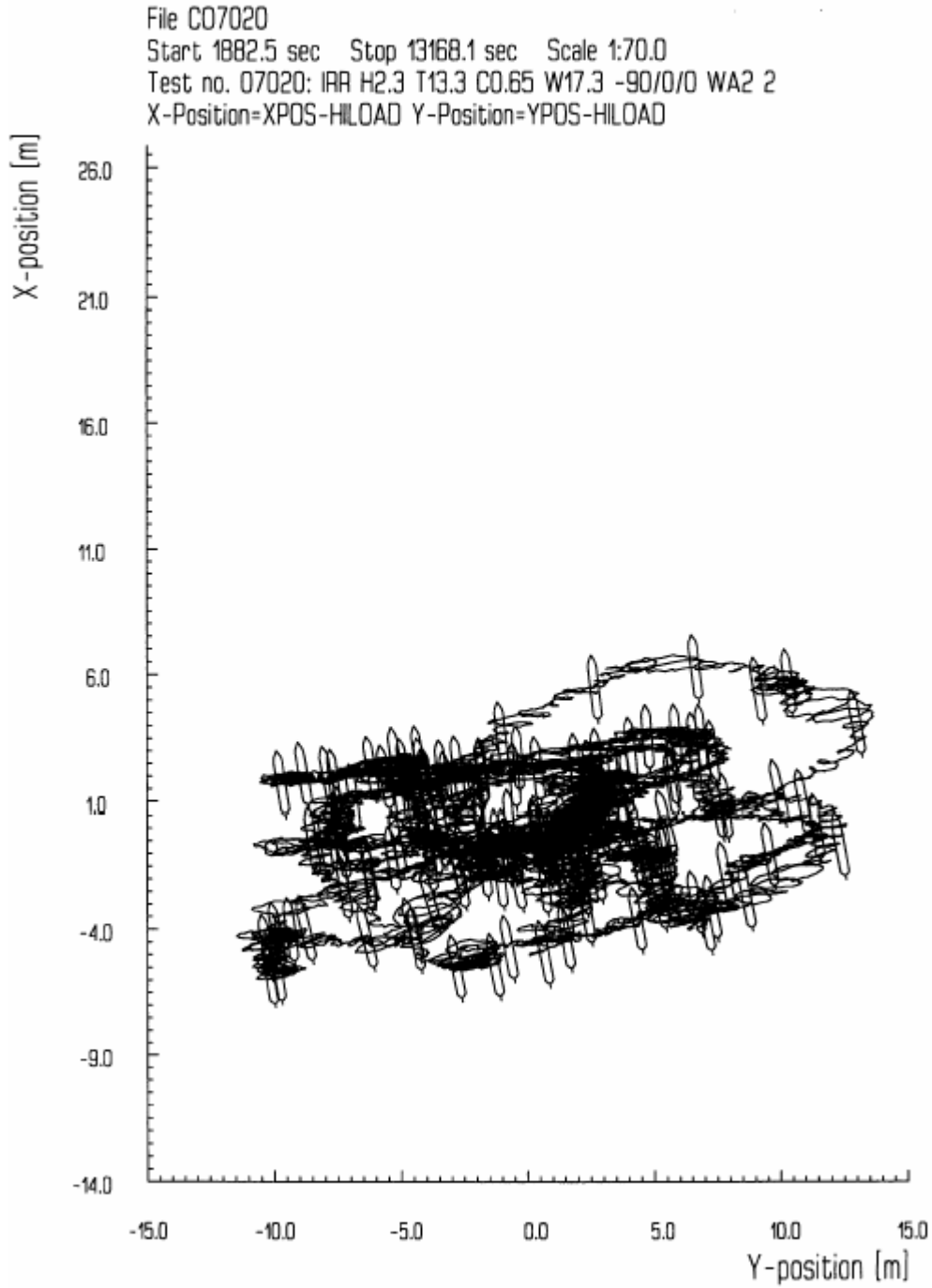

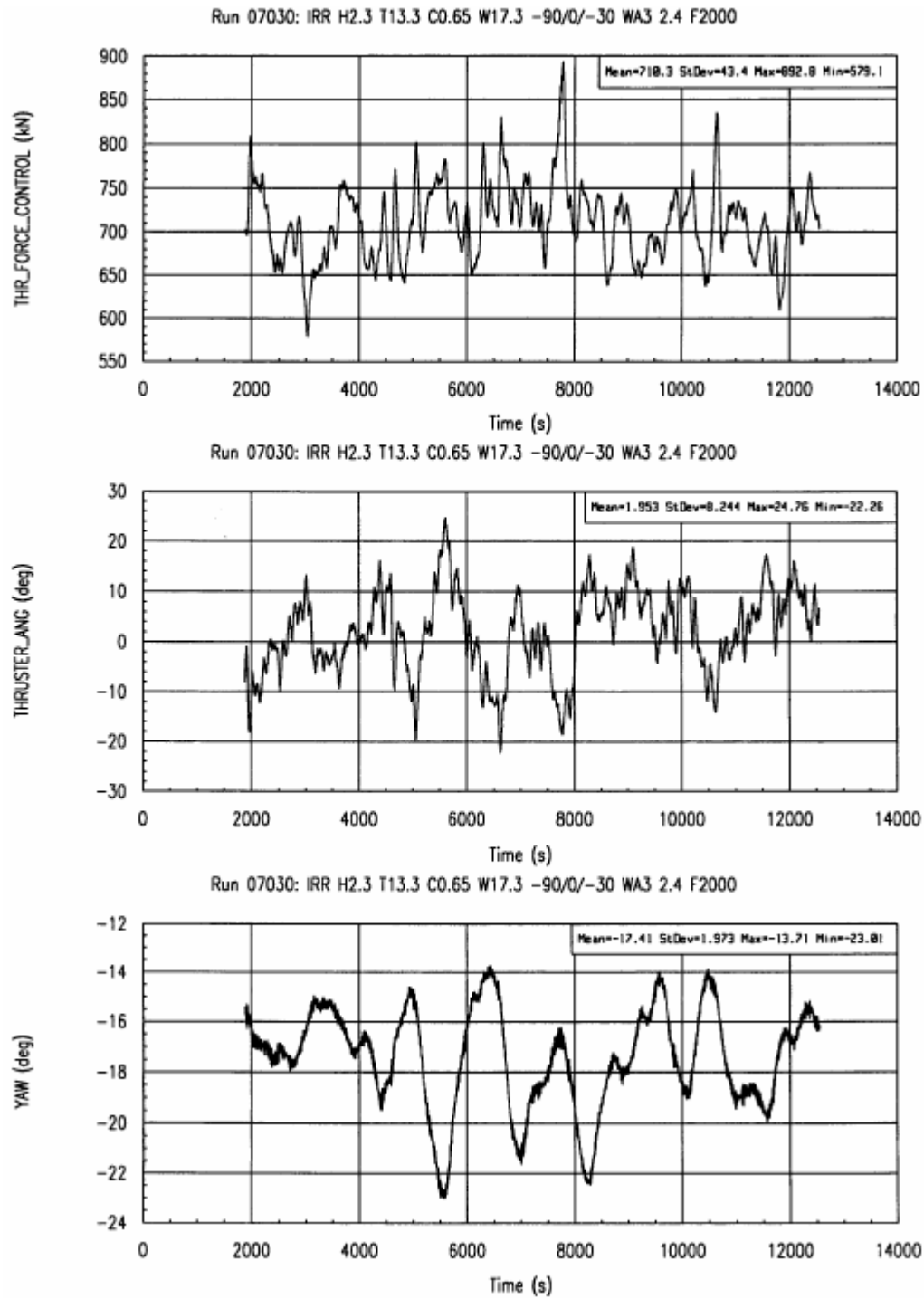

File C07030
Start 1882.5 sec Stop 12549.8 sec Scale 1:70.0
Test no. 07030: IRR H2.3 T13.3 C0.65 W17.3 -90/0/-30 WA3
X-Position=XPOS-HILOAD Y-Position=YPOS-HILOAD

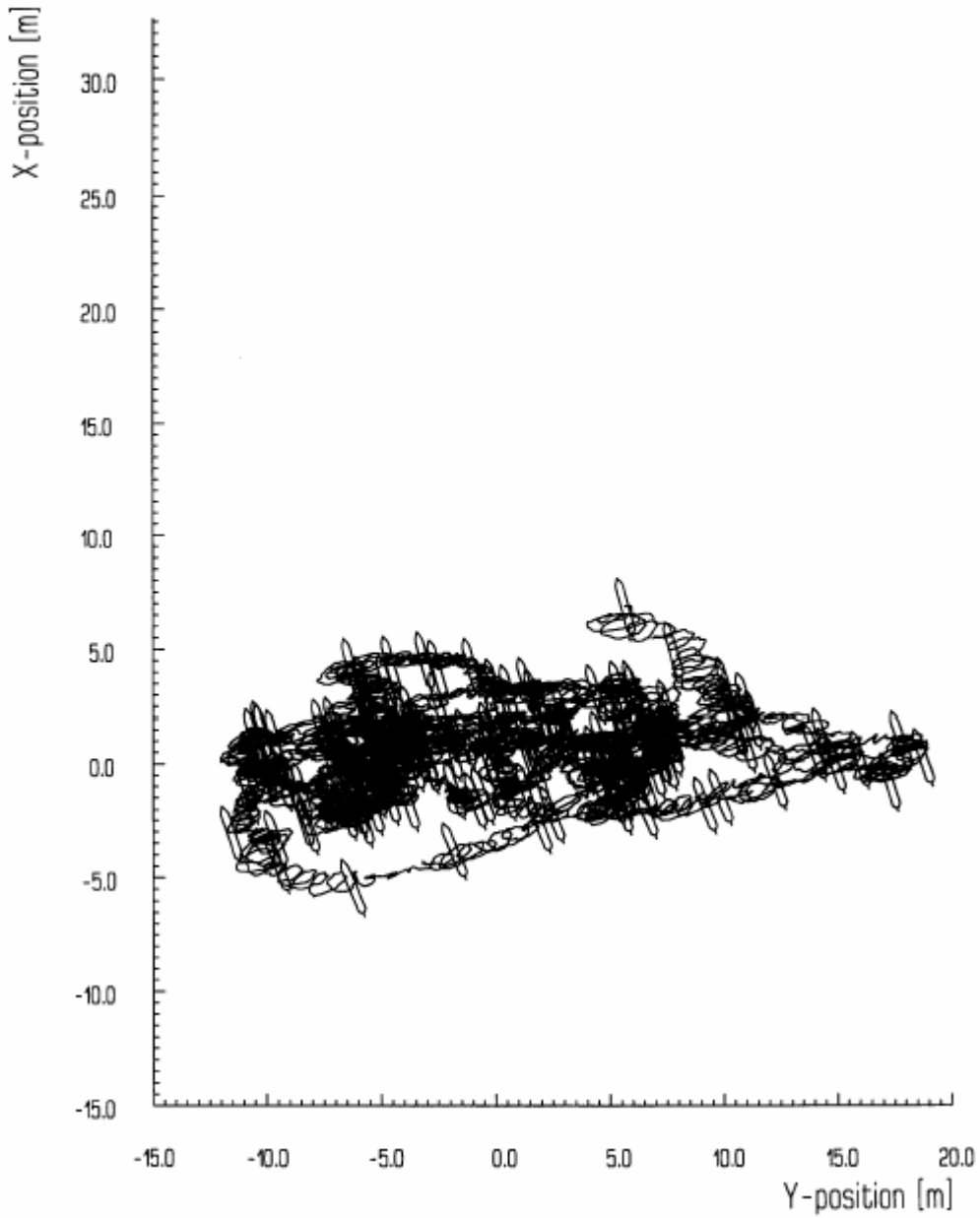

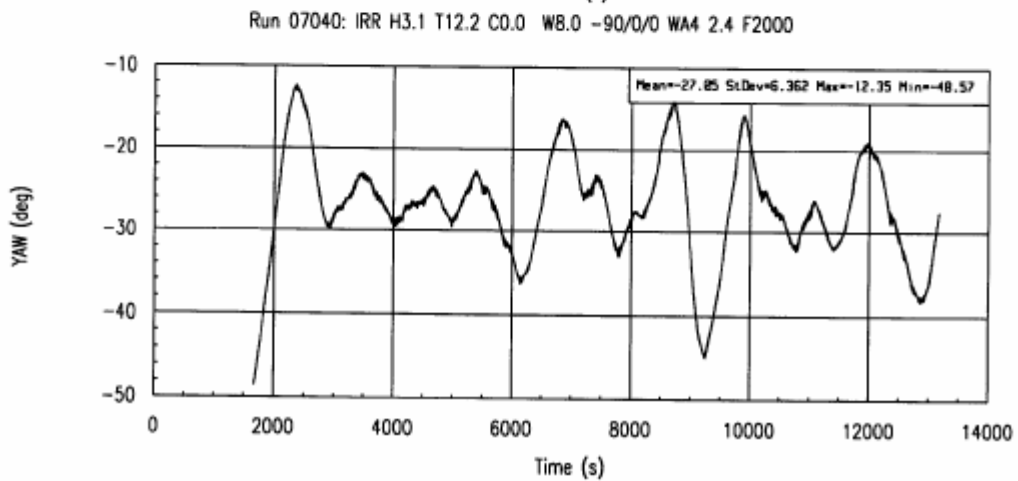
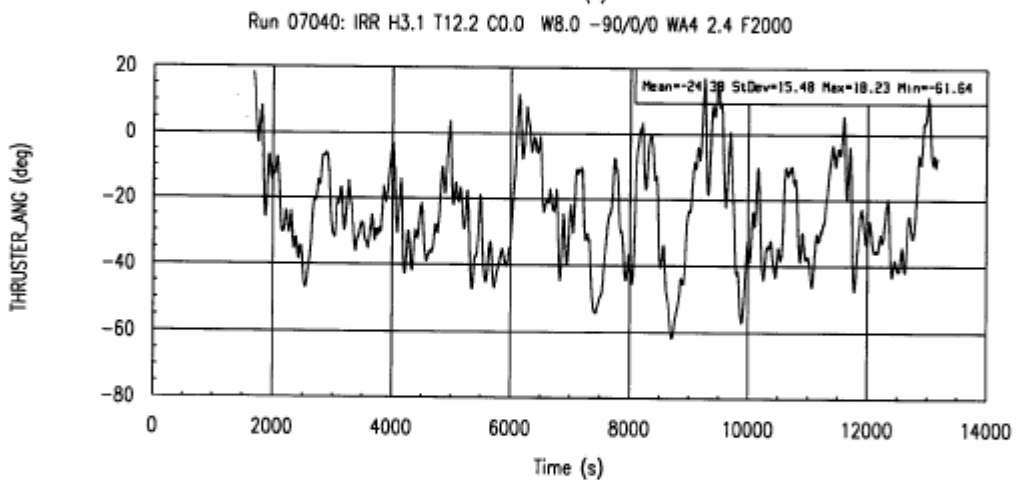
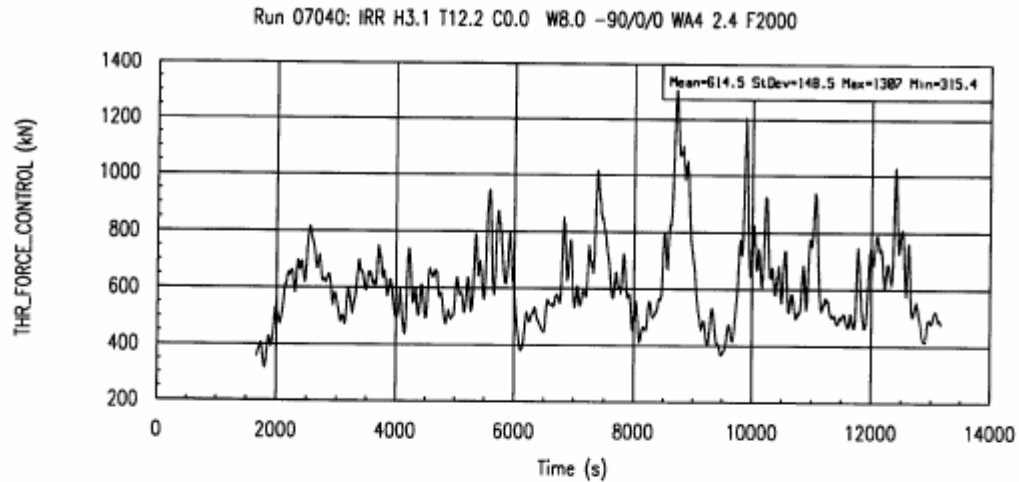

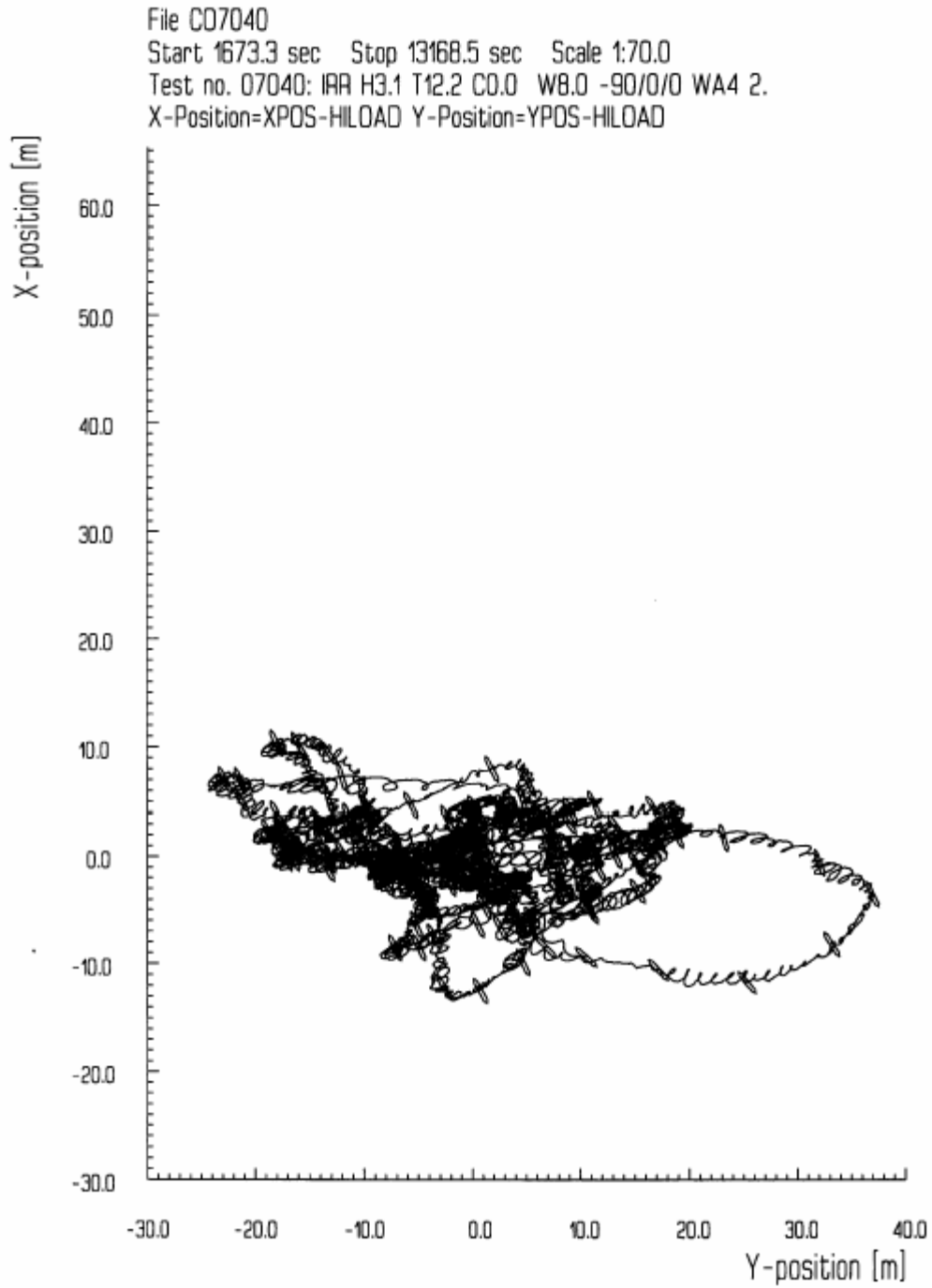

A.3 3RD PARTY VERIFICATION

DnV has carried out a 3rd party verification. Based on the review, they have issued an "Approval In Principle", ref. copy of letter shown below.

DET NORSKE VERITAS

HITEC MARINE AS
Vikaveien 85

4816 KOLBJØRNSVIK
Norway

Att: Claes Olson

Your ref.:

Our ref.:

OCT730P/STOR/73000000-J-4272

Date:

2001-09-18



DET NORSKE VERITAS AS
Offshore Classification &
Technical Services
*Offshore Systems, Equipment and
Arrangements*
Veritasveien 1
1322 Høvik
Norway
Tel: +47 67 57 99 00
Fax: +47 67 57 99 11
<http://www.dnv.com>
Org. No: NO 945 748 931 MVA

HiLoad - Approval in Principle

Reference is made to request by Hitec Marine as pertaining to "Approval in Principle" of their Hiload Offloading System concept. DNV has on the basis of this request, and in commercial confidence, reviewed input and participated in meetings with Hitec Marine. From the review conducted, DNV have no principal objections, and regard the Hiload Offloading System concept presented as being feasible.

On this basis, an "Approval in Principle" is granted, subject to the critical and unresolved design issues being addressed and resolved in accordance with relevant Classification Rules, recognised codes and standards.

The objective is to provide a safe and efficient means of Crude Oil transfer to the offshore industry, and the success is contingent on reliable operation for all relevant design conditions.

At this stage of the concept development, these include the elements listed below which are further described in the attachment to this letter:

- Global behaviour and station keeping
- Power supply
- Behaviour of pipe and connecting joints
- Marine systems
- Safety systems

DNV will be happy to assist you in providing qualification and verification services with regard to further development of supporting documentation and detailed design.

Yours faithfully
for DET NORSKE VERITAS AS

Svein Svarstad
Head of Department
Offshore Classification and Technical Services

Walther Storesund
Group Leader
Piping & Equipment

Head Office: Veritasveien 1, 1322 Høvik, Norway

1704277/DNV

A.4 RELIABILITY AND AVAILABILITY

DNV has carried out Regularity and Availability Analysis for the overall DP-Terminal System, see front page of report below.

DET NORSKE VERITAS



Det Norske Veritas (U.S.A.), Inc.
Region North America
16340 Park Ten Place, Suite 100
Houston, Texas 77084 USA
Telephone: 281-721-6600
Facsimile: 281-721-6906

<i>Client Company:</i> Remora Technology	<i>Project No:</i> 230-11799, Rev. No. 0
<i>Location:</i>	<i>Total Pages:</i> 7 + Appendices
<i>Client P.O. No:</i>	<i>Date:</i> April 14, 2003
<i>Report Title:</i> HiLoad Availability Analysis	
<p><i>Summary:</i></p> <p>Det Norske Veritas (U.S.A.), Inc. ("DNV") was contracted by Remora Technology to undertake a Reliability, Availability and Maintainability (RAM) study of the HiLoad System. This report documents the analysis for the HiLoad System. The main findings and conclusions are:</p> <ul style="list-style-type: none"> • The overall availability of the HiLoad System is estimated to 99.8%. • The largest contributor to unavailability is the Main Ballast Pumps. It must be noted that the overall availability is high and that even if the Main Ballast Pumps are the largest contributors, it represents only 0.14% overall unavailability. • Given the appropriate attention in the inspection planning, it is believed that the system will fulfill its required function with a high degree of availability. <p>The above result is due to the high degree of redundancy in the HiLoad systems. Practically all functions, where feasible, are redundant.</p> <p>Another important factor is that, even if the HiLoad is a completely new concept with respect to offloading, it is based on the use of established technology and materials that have a documented performance in similar conditions. One exception is the Suction Attachment System; however, this system has been the subject of thorough full scale testing.</p>	
<i>Keywords</i>	<i>Prepared By:</i> Bjorn Nilberg
<i>Project Type:</i>	<i>Verified By:</i> Stein Jemås
<i>Equipment:</i>	<i>Approved By:</i> Stephen J. Shaw
<i>Material:</i>	
<i>Damage:</i>	
<i>Other:</i>	
<i>Miscellaneous:</i>	