



POWER

Power Generation Stability and Response in DP Applications An Overview of Modern Diesel Engine Performance

Magnus Miemos, Wärtsilä Finland Oy

Session Chair – Don Wilkes, GlobalSantaFe

September 16-17, 2003
Houston, Texas

*Power Generation Stability and Response
in DP Applications - an Overview of
Modern Diesel Engine Performance”*

DP Conference 2003
by
Magnus Miemois
Director, 4-Stroke Systems

Topics Discussed in This Paper

1. Frequency control & load sharing
2. Interaction between speed governor and external systems (PMS)
3. Diesel engine performance
4. Potential methods of enhancing loading performance
5. Load sharing; symmetric vs. asymmetric

1.

Frequency Control & Load sharing

Frequency Control - Mission

- Maintaining a desired absolute frequency (isochronous) or frequency range (droop mode), using a speed governor or speed control unit to control the rpm of the diesel engine prime mover.
- Traditionally, mechanical - hydraulic governors
- Today, electronic speed control units with either hydraulic or electric actuators.

Frequency Control - Control Loop

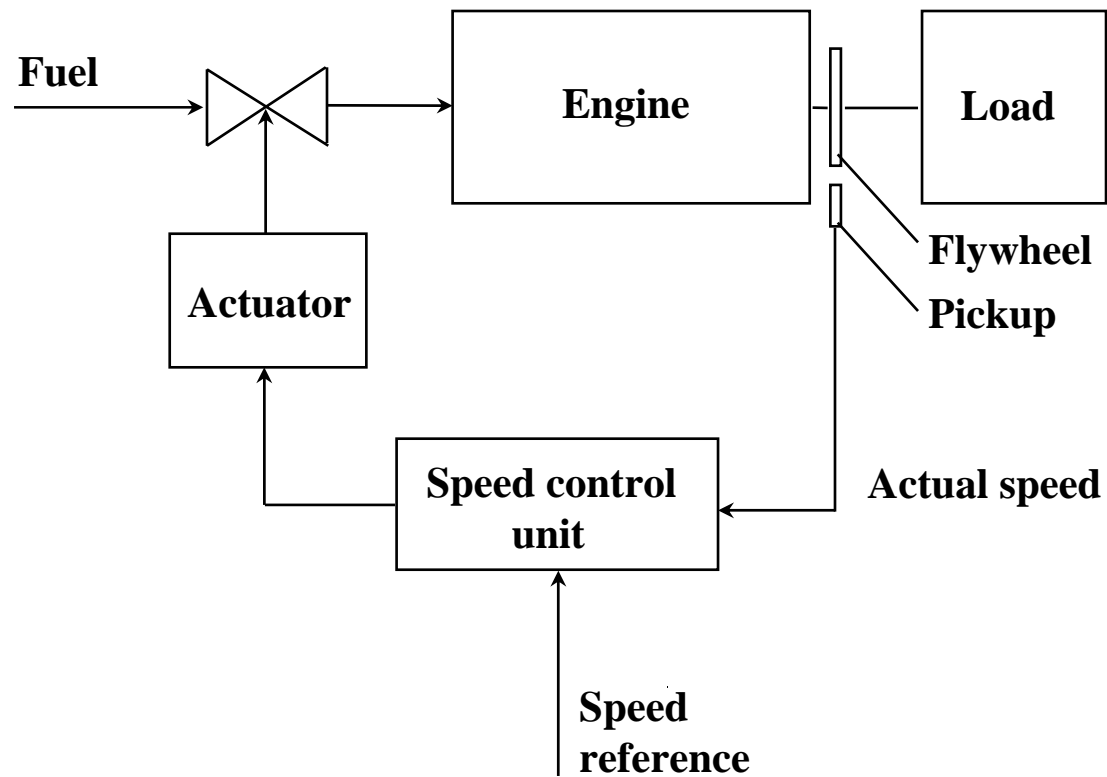

Frequency Control - Main Elements

Increase/Decrease Speed



Engine Load



Average Engine Load



Engine Speed



Control Output
0 - 200mA



Actuator
Position 0 - 10

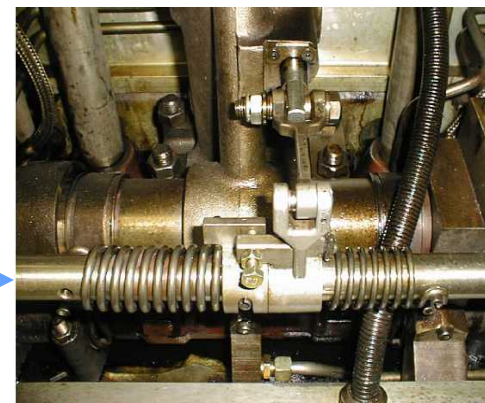

Fuel Rack
Position
0 - 56 mm



Signals, Example of Relationships - Example

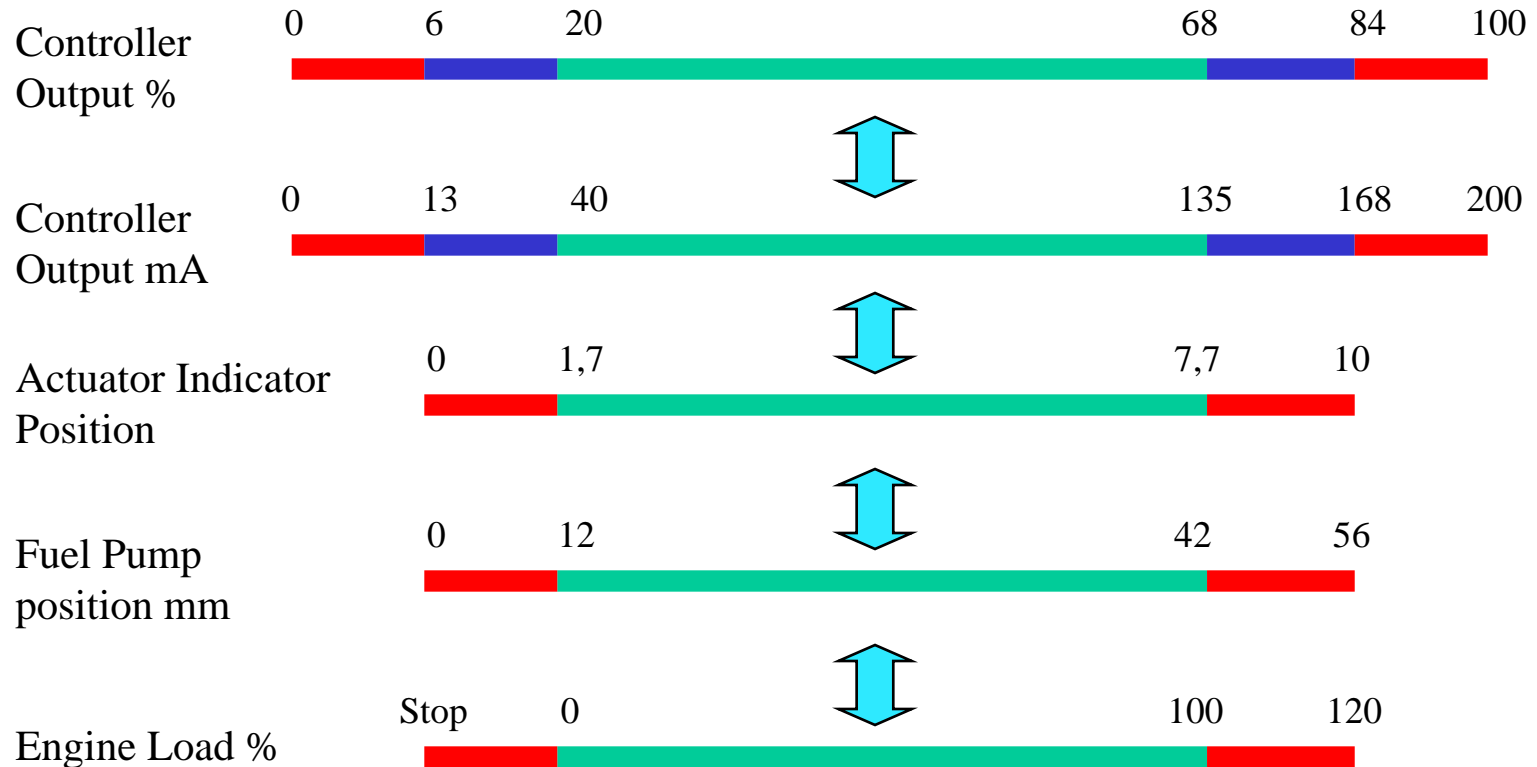

Load Sharing - Droop Mode

Frequency Hz

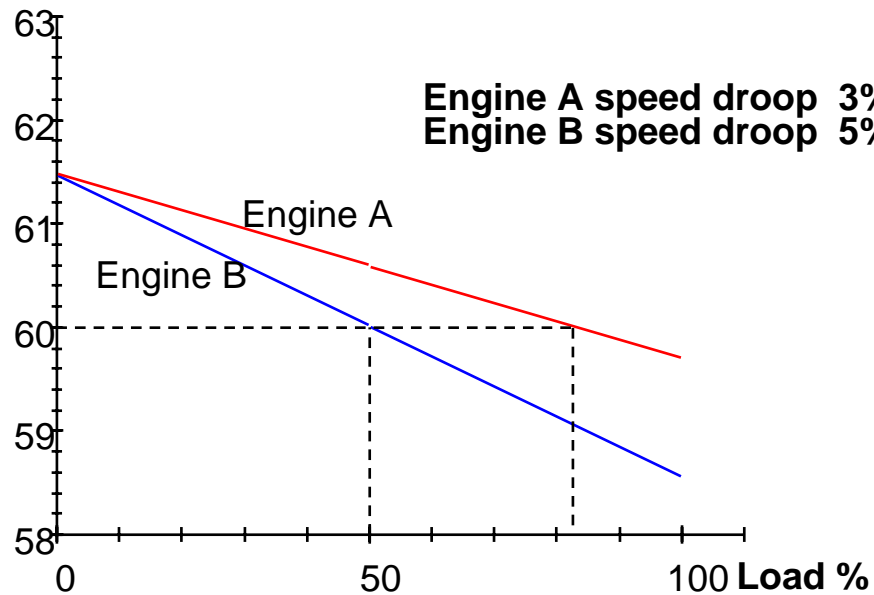

Frequency Hz

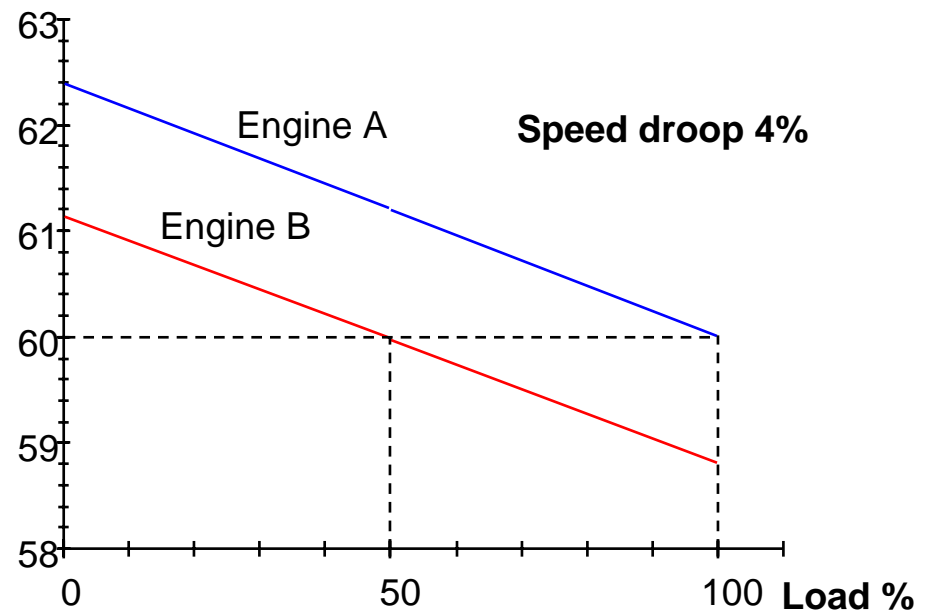

Engines which are connected to a common load must have the same speed reference and the same speed droop % in order to share the load equally.

Load Sharing – Isochronous Mode

- Load sharing lines between speed control units.
(-Voltage signal proportional to average load level)
- No speed droop, fixed frequency.

Some issues:

- Short circuit on load sharing lines paralyses load control
(but gensets resort to independent droop mode operation. –not fatal).
- Wire break more critical. Will lead to unstable situation.
- Today's speed control units do not have galvanically isolated load sharing lines. –A voltage induction could (in theory) knock out the speed controllers.

Coming technology:

- Digital load sharing lines.

2.

Interaction Between Speed Control and External Systems (PMS, etc.)

Speed control & PMS

- Distinguish between *Load Sharing* and *Load Balancing*.
- The governors *share* the load, both in speed droop systems and in isochronous systems, while the PMS can *balance* or *offset* the load.
- The PMS should ideally adjust the load balance only when a generator is recently connected, or before disconnecting a generator in a speed droop system.
- The governors work to eliminate short term frequency fluctuations (seconds).
- The PMS should correct only long term frequency changes due to changed network load (minutes).

Speed control & PMS

In Droop Mode:

- PMS does not control load directly, governors load share.
- PMS performs *frequency correction and load balancing* by adjusting the load reference signal to the speed control unit (ref. droop curve)

Remember:

- Speeding up the PMS update (control) rate does not increase system response. (It rather makes it unstable).

In Isochronous Mode:

- PMS does not control load directly, governors load share on load sharing lines.
- PMS does not balance the load. The load is normally shared equally.
- PMS cannot affect frequency after synchronizing.

3.

Diesel Engine Performance

Diesel Engine Functions/Features Critical for Performance & Response

- Turbocharging System
- Fuel injection system
- Brake Mean Effective Pressure
- Acceleration value (a-value)

Little or no influence:

- Bore & stroke
- Number of cylinders
- RPM
- V-engine vs. in-line

Turbocharger

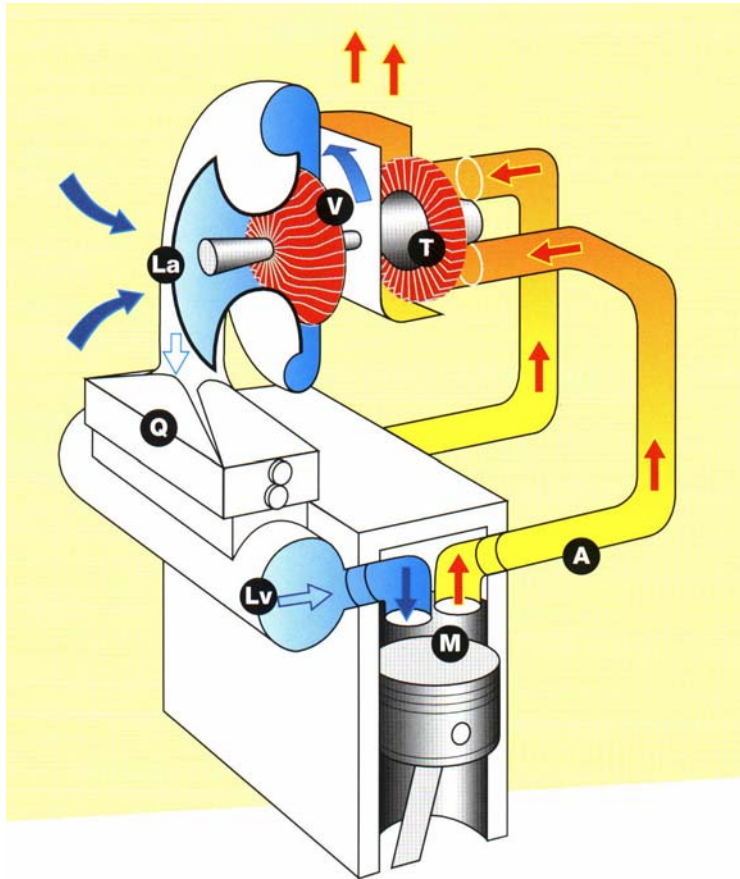

Modern diesel engines:

The turbocharger stands for 75-80% of the rated power.

Development of charge air pressure ratio

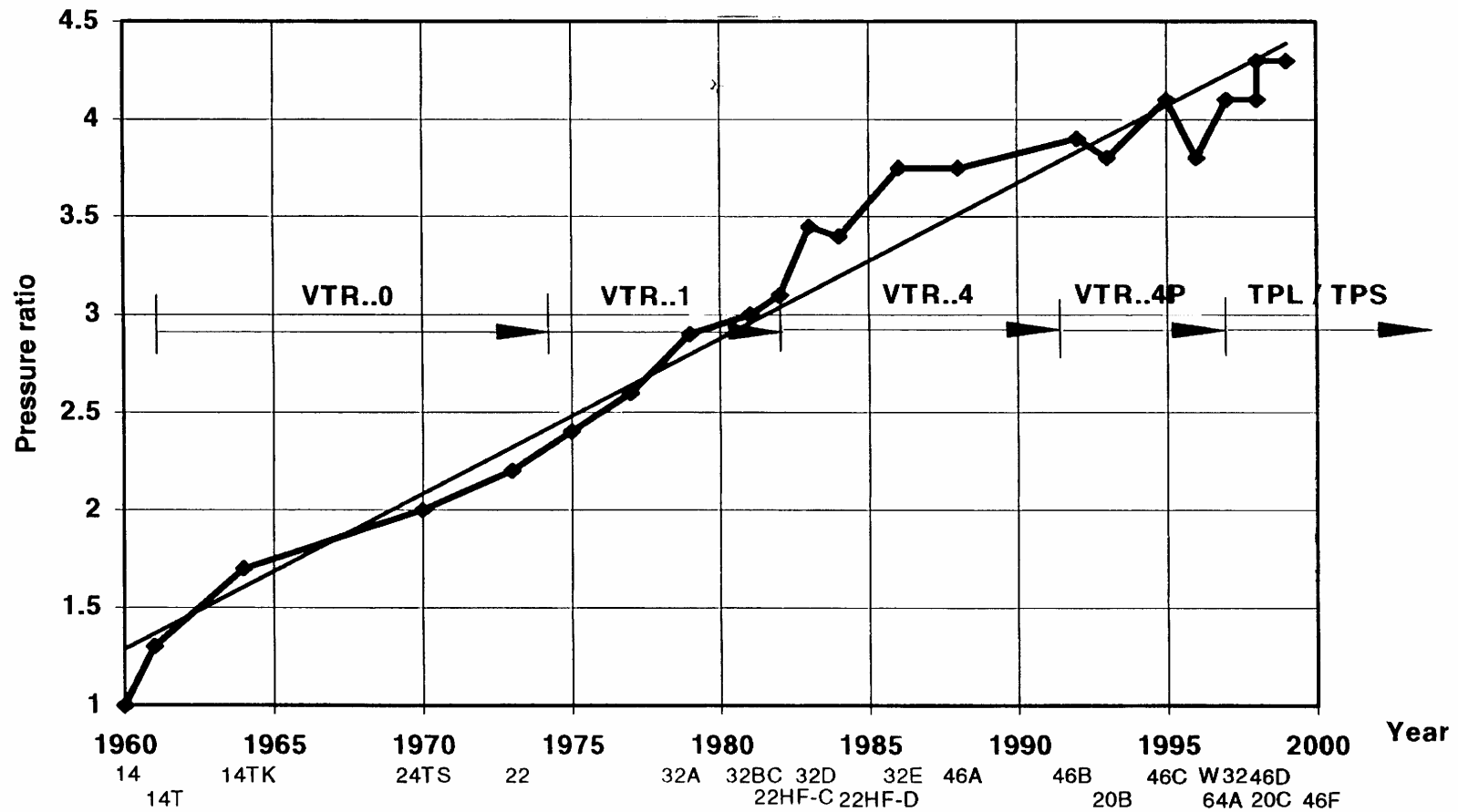

Efficiency Development of Wartsila Engines

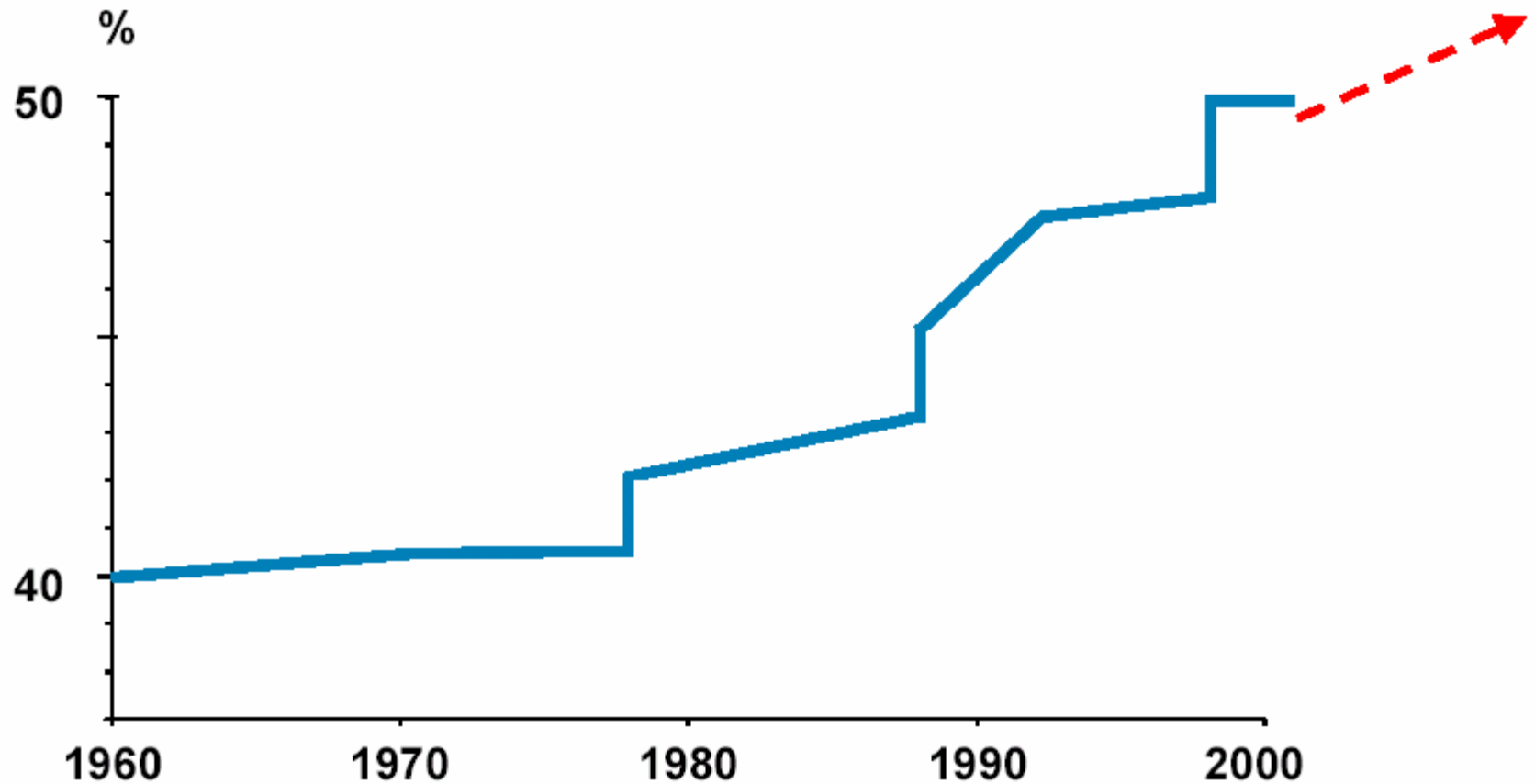

Charging systems

Pulse charging systems, cylinder numbers with multiple 4 (4L, 8L, 8V, 16V).

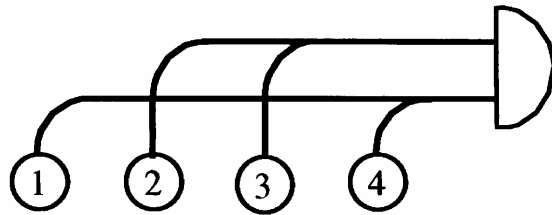

2-Pulse

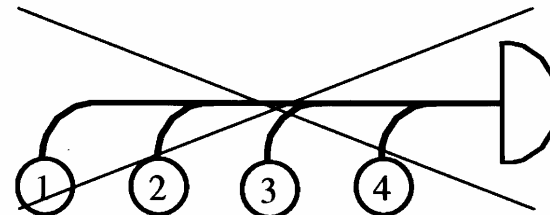

4-Pulse

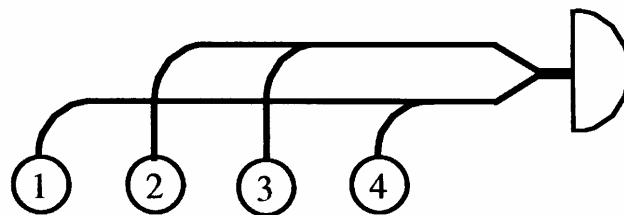

Pulse Converter (PC)

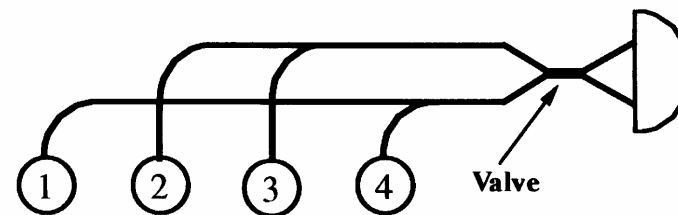

Combi (2-Pulse / PC)

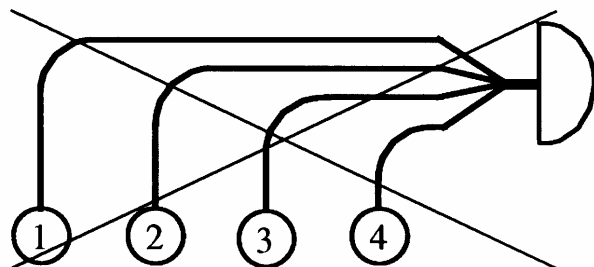

Multi Pulse Converter (MPC)

Charging systems

Pulse charging systems, cylinder numbers with multiple 3 (6L, 9L, 12V, 18V) and 5 (5L, 10V, 20V).

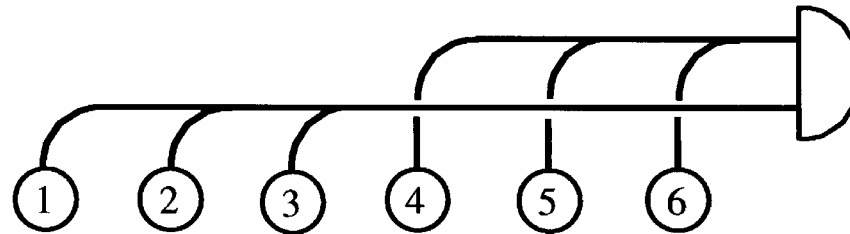

3-Pulse

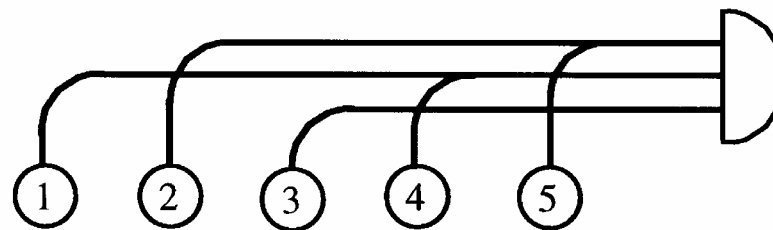

"2 - 1 - 2 Pulse"

Charging systems

Pulse Charging

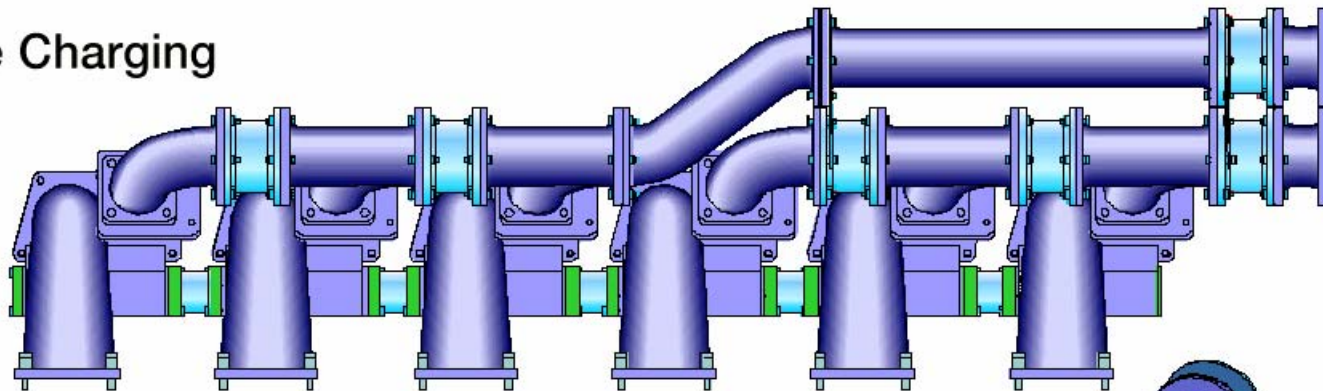

Spex Charging

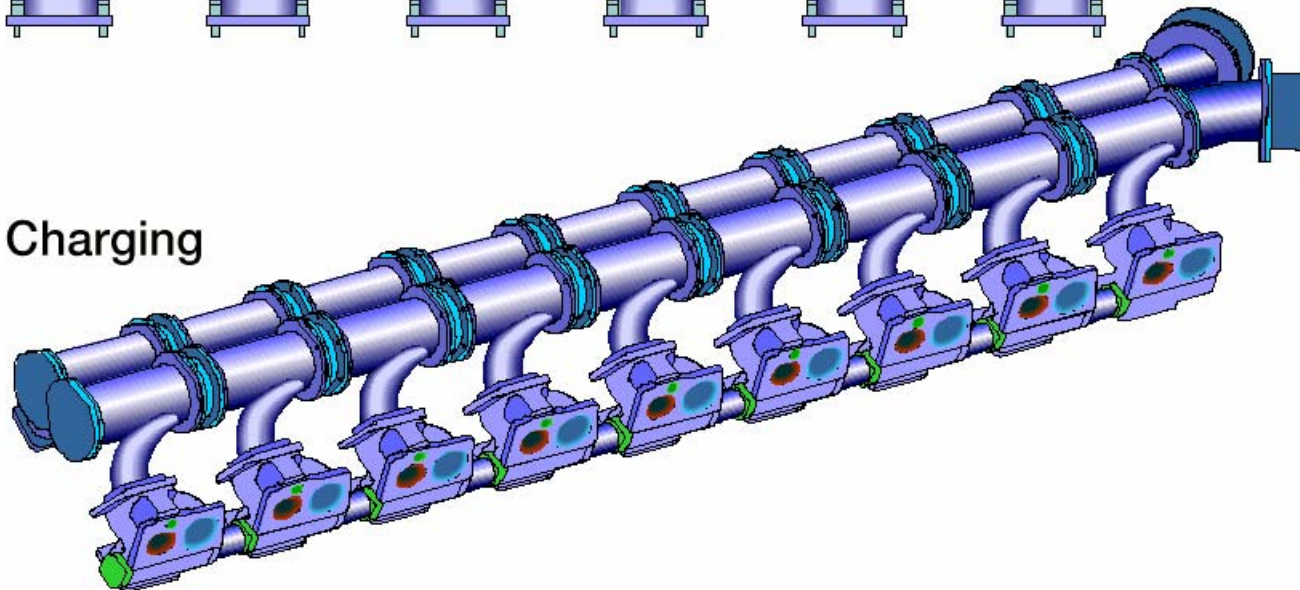

-Avoid "constant pressure" turbocharging.



Technology advancements - Turbochargers

- Variable Geometry Turbochargers
 - Variable nozzle ring vane angle
 - Today used on gas engines
 - Improves performance envelope, but will not dramatically improve the situation in rapid transients.
 - Mechanically more complex

Technology Advancements - Fuel Injection

Conventional injection system

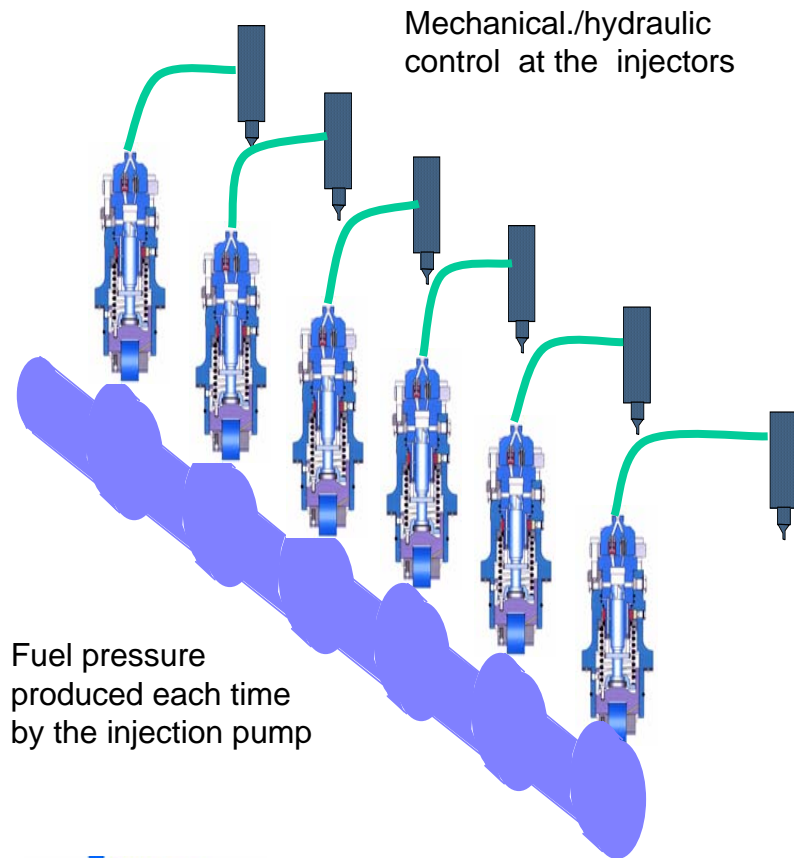

Common Rail Injection

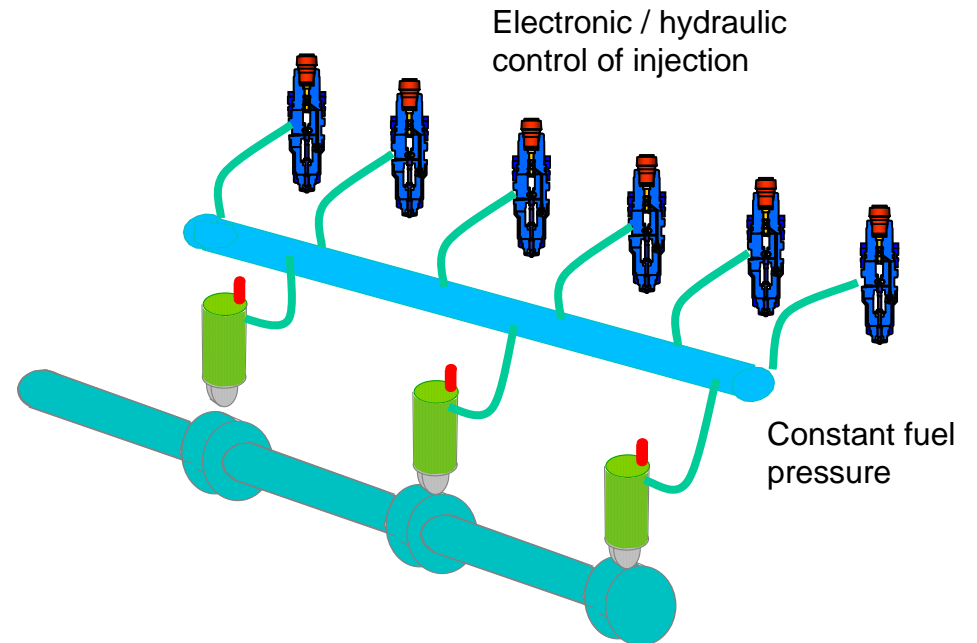

WÄRTSILÄ COMMON RAIL SYSTEM

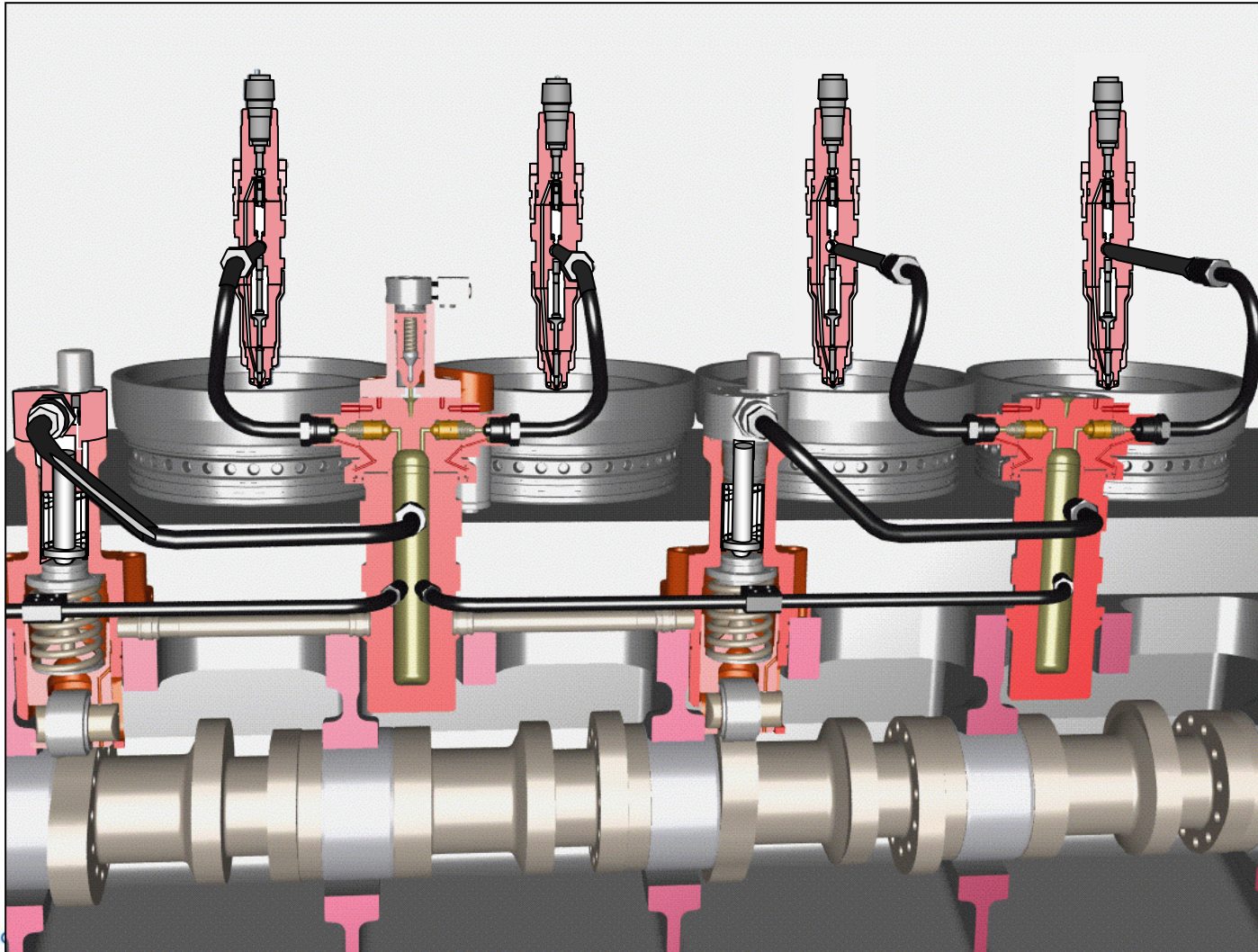

WÄRTSILÄ COMMON RAIL SYSTEM

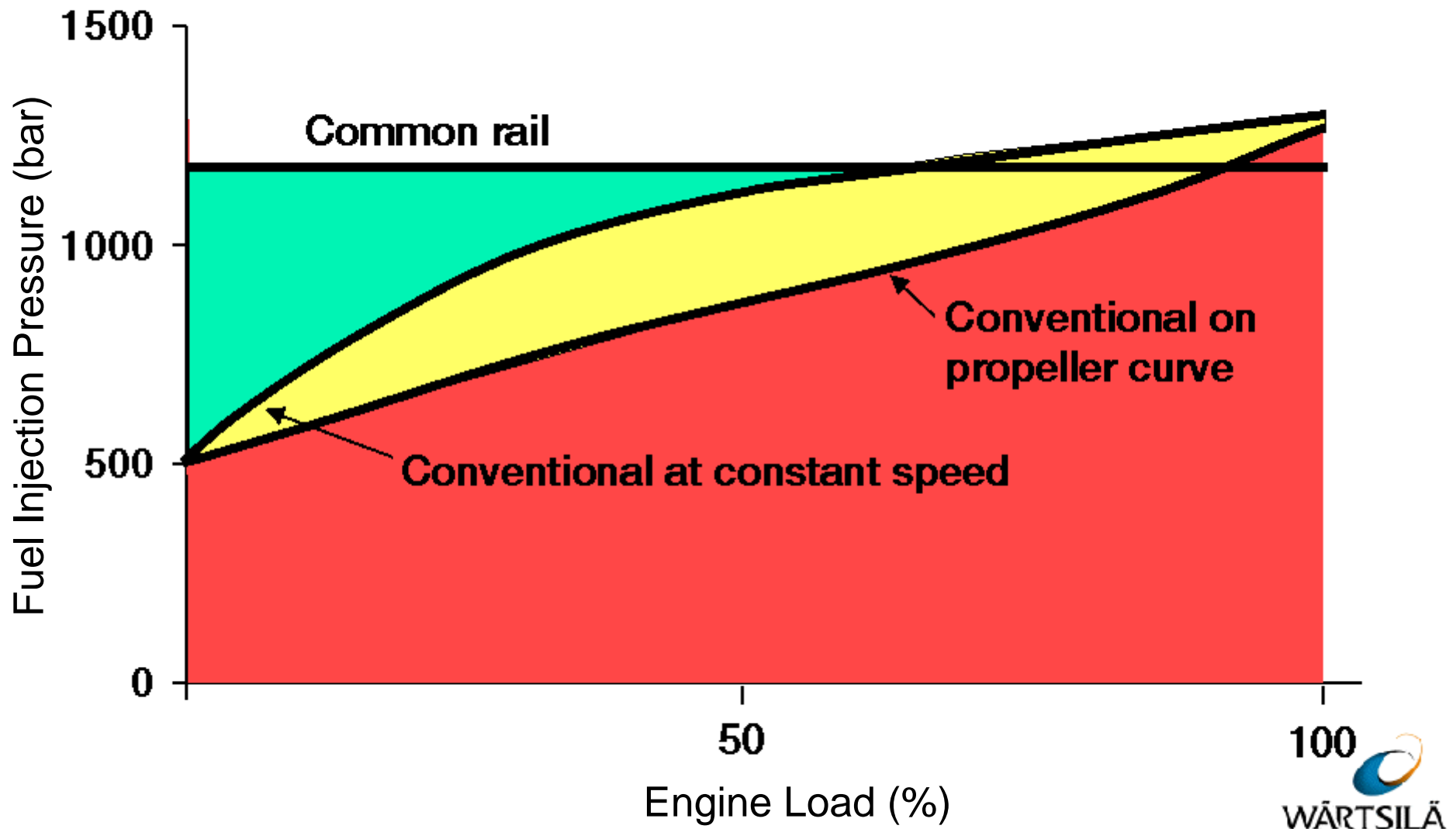

- By definition, the mean pressure on the piston calculated over the entire cycle.
- Indicates how much power output is produced for a certain bore / stroke / rpm.
- Indicates “development stage” of engine

$$BMEP[bar] = \frac{1}{100000} * \frac{Power[kW] * 1000 * 4 * Stroke[2or4]}{\left(\frac{Bore[mm]}{1000}\right)^2 * \frac{Stroke[mm]}{1000} * \pi * 2 * \frac{RPM}{60} * NUMCYL}$$

Example:

“Vesslefrikk” -1985: 12V32BC, BMEP = 20.1 bar

“Deepwater Horizon” -2000: 18V32LNE, BMEP = 24.0 bar

- Indicates the acceleration properties of a rotating mass (e.g. alternator)
- Detailed genset performance optimization should include optimization of the a-value (flywheel, coupling, generator rotor, etc.)
- Performance simulations reasonably good indicator for correct (driver / flywheel / alternator) configuration selection.

4.

Can Loading Performance be Improved
Using Special “Gadgets”?

Potential Gadgets

- Air injection in turbocharger
 - Large air consumption
 - Controls tends to always lag
- Mechanical blower
 - Widely used for 2-stroke engines (a must)
 - unpractical on 4-stroke engine, too big parasitic loss.
- Hydraulic (or electric) forced rotation of turbocharger
 - Was used already in the 1960s on e.g. icebreakers
 - high rotational speed is a technical challenge

Drilling is difficult !

–Load swings are somewhat unpredictable,

....

Innovative Control Schemes

- Load feed forward

- Electrical load demand (changes) are fed forward to the speed control.

- Electrical actuators

- Reduced lag
- Technical maturity ?

5.

Load Sharing Symmetric vs. Asymmetric

Symmetric vs. Asymmetric Load Sharing

- Asymmetric load sharing is a valuable operating mode e.g. after engine overhauls (running in new components) or when power output is limited due to technical reasons (contaminated alternator heat exchanger, thermal overload above certain % load, etc.)
- PMS should be able to recognize “maximum power available” for each unit in order for asymmetric load sharing to be practical.
- Occasional load drops below the level of the lowest loaded generator must be avoided in a speed droop system to avoid tripping on reverse power.

Thank You !



[Return to Session Directory](#)

