



**DYNAMIC POSITIONING CONFERENCE**  
**September 16-17, 2003**

**POWER SESSION**

---

**Single Point Failures in Traditional Implementations of Power  
and Load Management Systems**

Russell Hodge

*C-MAR America Inc. (Houston)*

---

## Table of Contents

1	Introduction .....	3
2	Governors and Load Sharing: An Overview.....	4
3	The Electronic Governor .....	4
3.1	Isochronous Control.....	6
4	Distributed Load Sharing .....	7
5	The Woodward Digital Loadsharing Solution .....	9
5.1	The 828 as Network Monitor.....	10
6	PLC Based Load Monitoring .....	11
7	An Economic Distributed Solution.....	12
8	Hybrid Control .....	13
9	Conclusions .....	14
9.1	Droop Mode .....	14
9.2	Isochronous mode .....	14
9.3	Analogue Isochronous Control.....	14
9.4	Digital Isochronous Mode .....	14
	References: .....	15

## Table of Figures

Figure 1	The Watt Steam Governor 1788.....	4
Figure 2	Basic Electronic Control with Droop Function.....	5
Figure 3	Frequency as a function of Load: Droop Operation.....	5
Figure 4	Basic Electronic Governor with Isochronous Control.....	6
Figure 5	Typical Class 2 DP D-E Switchboard .....	7
Figure 6	Distributed Load Management System.....	8
Figure 7	Standard Digital Load Share Network.....	9
Figure 8	Woodward 828 LON Monitor.....	10
Figure 9	PLC Based Load Share System.....	11
Figure 10	Distributed Load Management, OEM.....	12
Figure 11	Hybrid System, Legacy Automation.....	13

## 1 Introduction

Efficient load control of electrical generating plant is of critical importance to the operation of a DP Classed vessel.

Although DP vessels have been operating for almost thirty years and Classification Society Rules governing the design and construction of such vessels have been in place, and undergoing continuous revision, since the nineteen eighties, experience has shown that a number of misconceptions remain where loadsharing systems are involved.

This paper seeks to identify the most common load control and power management philosophies, their strengths and weaknesses in relation to DP classification and to assist the system designer in determining the most suitable implementation for a given project application.

Although a number of design solutions exist in the more complex implementations the basic topologies and philosophies are largely similar and will be treated generically in the paper. However, in less complex systems solutions may be unique to a particular manufacturer. In such instances the manufacturer will be specifically identified. This identification is not intended to indicate the author's endorsement or preference for any one product in relation to another.

## 2 Governors and Load Sharing: An Overview

All generating sets require some form of load control. This is true even for single generator operation. The central component in any load control scheme is the engine governor. Two principal governor types are available:

1. Mechanical
2. Electrical/Electronic

The basic operating characteristics and principles of mechanical governors have changed little since the invention of the Steam Engine Governor by James Watt in 1788. The governor works by means of heavy balls, which rotate on the end of linkages and move in or out because of centrifugal force according to the speed of rotation. The movement of the balls closes or opens the steam valve to the engine. When the engine speed increases too much, the balls fly out, and cause the steam valve to close, so the engine slows down. The opposite happens when the engine speed drops too much.

Instead of controlling steam valves, the modern diesel mechanical governor controls the position of the fuel rack on the engine and regulates the flow of fuel into the cylinders.

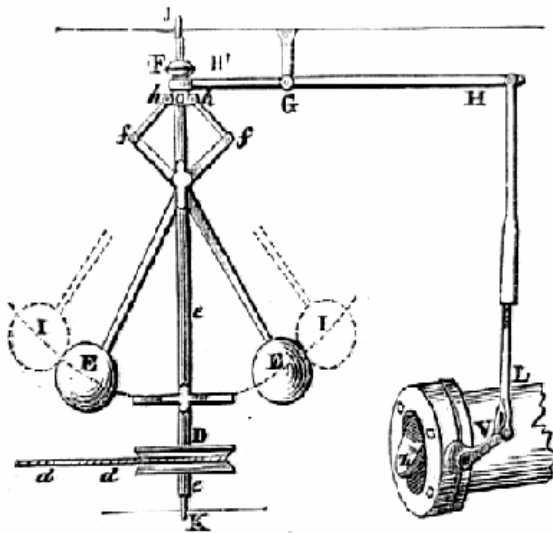
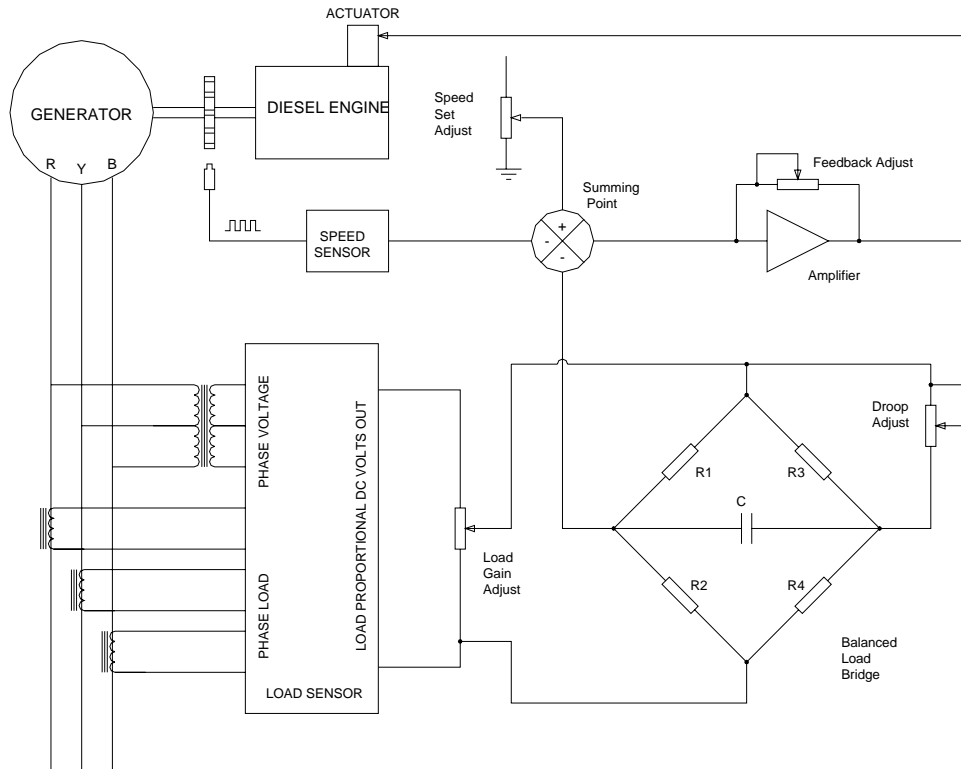

Figure 1 The Watt Steam Governor 1788

## 3 The Electronic Governor

The electronic governor, which may use analogue or digital means, seeks to replicate the actions of its older counterpart using electronic sensors to detect flywheel speed and electrical load.

Electrical load is determined by measuring the inter-phase voltage and current drawn from the generator, a proportional DC voltage is applied to a summing point where it is compared with the speed signal derived from a magnetic pick up device on the engine flywheel. The resultant output is applied to an amplifier which produces the drive signal for the engine fuel rack actuator.



**Figure 2 Basic Electronic Control with Droop Function**

Droop is a means by which the engine may be regulated such that its speed is proportional to the load taken. By fixing such a value several generators may be connected in parallel and broadly share the total load. This is the purpose of the resistor bridge network shown in Figure 2.

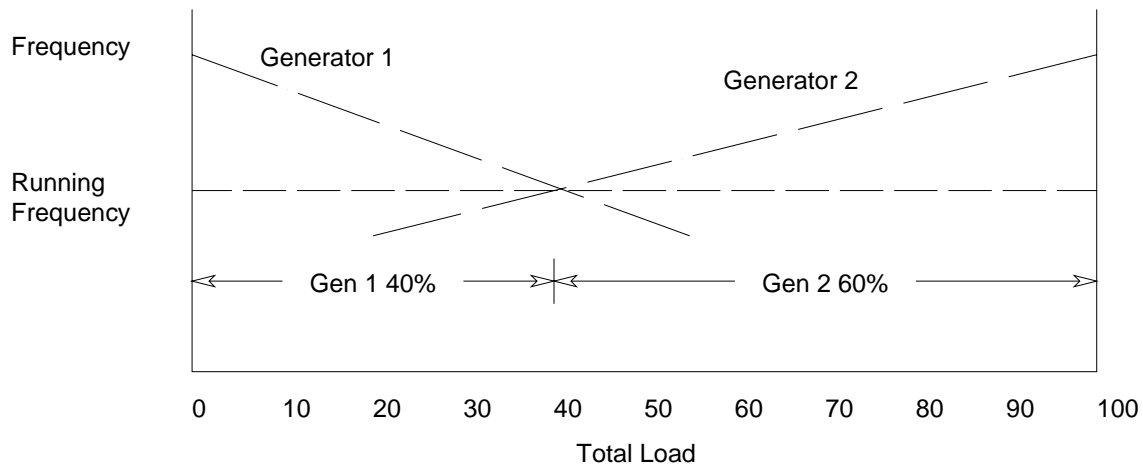

**Figure 3 Frequency as a function of Load: Droop Operation**

### 3.1 Isochronous Control

Isochronous control of a number of generators may be accomplished by disconnecting the Droop Adjust resistor and connecting the voltage developed across this point to the same point in the other generators connected to the bus. In this way the load shared may be directly proportional to the relative capacities of the connected generators. This is illustrated in Figure 4.

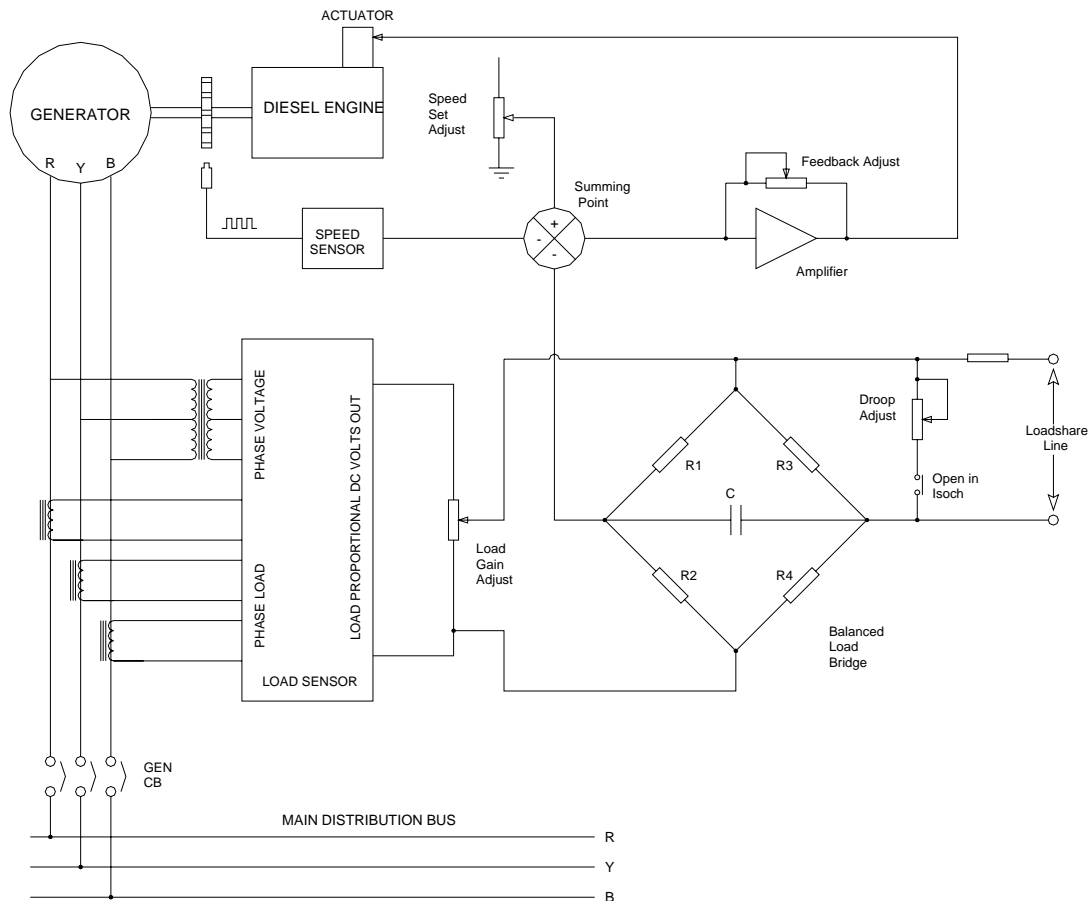

**Figure 4 Basic Electronic Governor with Isochronous Control**

This circuit is the basis of all analogue load sharing devices on the market today.

It can readily be seen that a short circuit across the load share point in the bridge circuit would result in all connected generators being commanded to reduce speed to minimum and shed all load.

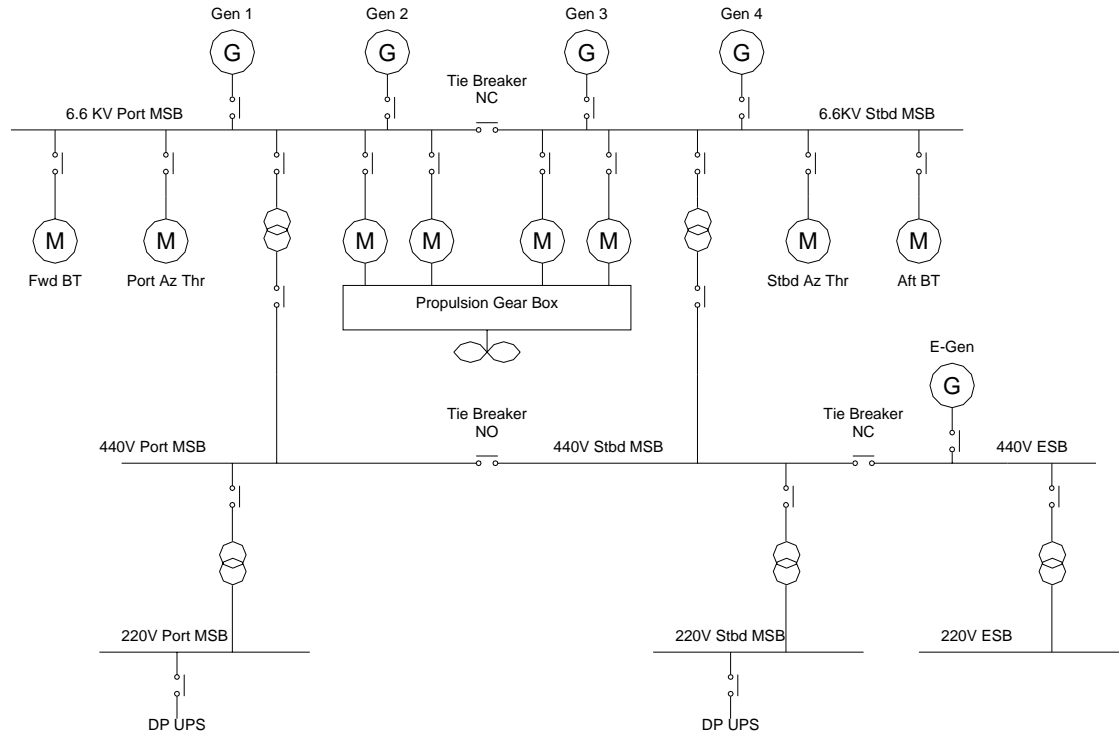

**Figure 5 Typical Class 2 DP D-E Switchboard**

Figure 5 shows a typical layout of a second generation DP diesel-electric Class 2 vessel. It is apparent that, since the main tie breaker is normally closed, if an analogue load isochronous sharing scheme as described above is installed, short circuit of the load sharing bus will result in blackout.

Where such a risk is known to exist, it has been recommended that the bus be operated in open tie-breaker mode. In this instance it can be seen that any disturbance of the balance between the port and starboard main boards may result in one set of propulsion drives being driven by the set on the board which adopts the higher frequency and hence being tripped from the board by their protection devices.

## 4 Distributed Load Sharing

In distributed loadsharing topologies the load information is passed on some form of serial data communications network between either individual governors or a centralised power management system.

On large installations, such as current generation drilling vessels, distributed load sharing is often performed as part of a distributed vessel management system. Such a system is illustrated in Figure 6

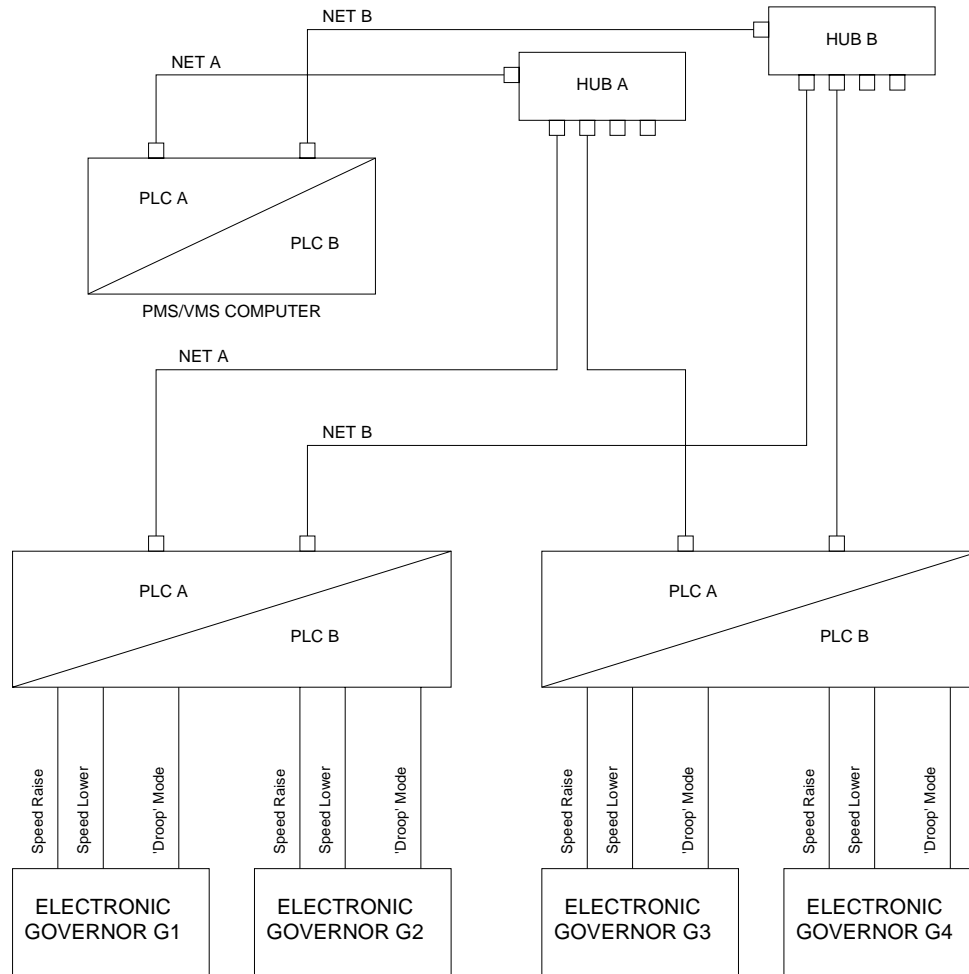

**Figure 6 Distributed Load Management System**

In this format there are several layers of redundancy, the power management controllers, the communications network, the PLC controllers and, finally, the governor.

In such installations it is common to operate the governor in 'droop' mode with external control of speed, and therefore load, being exercised by the power management network. It can be seen that, two faults are required in any part of the control system before the governor is forced into droop mode.

Networks of this type have been successfully implemented by ABB, Kongsberg, Alstom and Nautronix and may be adapted to reflect the main bus configuration with any one PLC controlling more than one individual generator set.

Installation of a distributed vessel management system with such high levels of redundancy and complexity require considerable capital expenditure and for this reason the designers of smaller vessels, such as OSV's must seek more cost effective solutions to the issues of load control.

## 5 The Woodward Digital Loadsharing Solution

The Woodward Governor Co. has an extensive range of intelligent digital load control equipment. Products include electronic governors and automatic synchronising modules. Much of the product range uses the Echelon™ communications bus protocol for data communication. A typical example of an automatic bus control network is shown below in Figure 7.

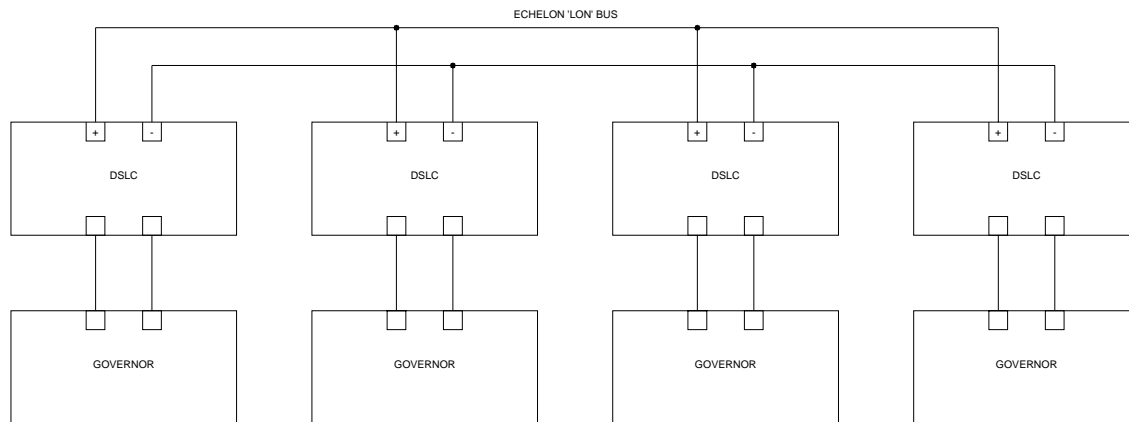
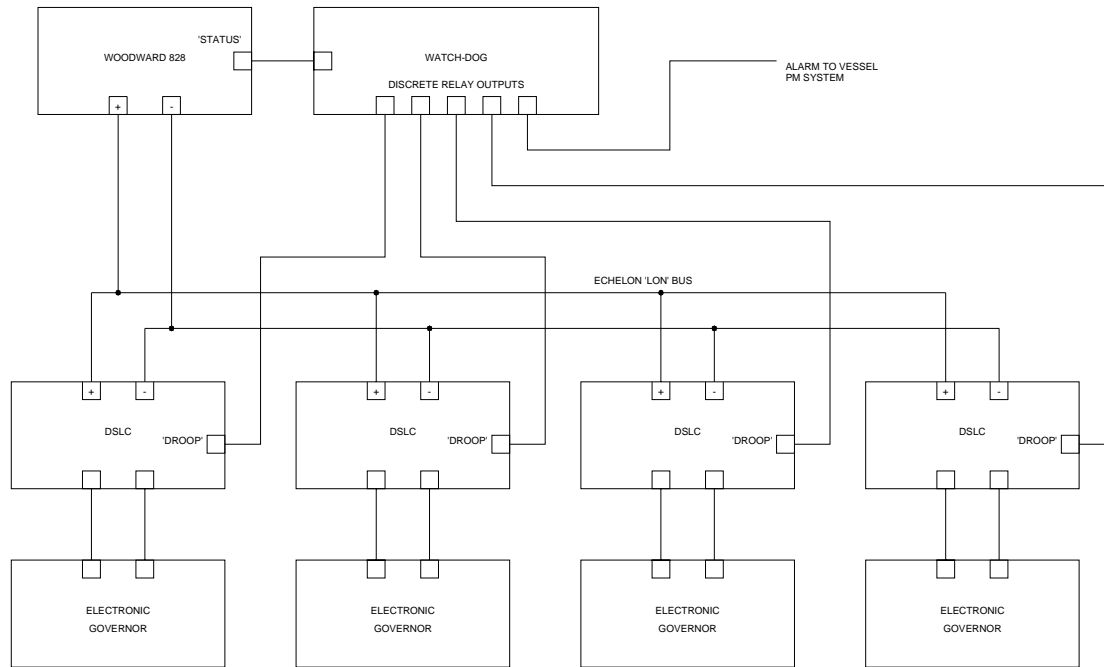

**Figure 7 Standard Digital Load Share Network**

Although the Echelon™ bus is highly reliable and used in a number of industrial applications it is apparent that no bus redundancy is available in the event of a short circuit across the communication net. The internal software for the products does not monitor bus activity and the default condition of the controllers would be last speed commanded in the event of total communication failure. It is clear that this condition does not meet the requirements of DP Class 2 redundancy.

## 5.1 The 828 as Network Monitor

In recognition of the failure mode described above Gerhardt's Inc of New Orleans have devised a solution based upon type approved equipment within the Woodward product range.

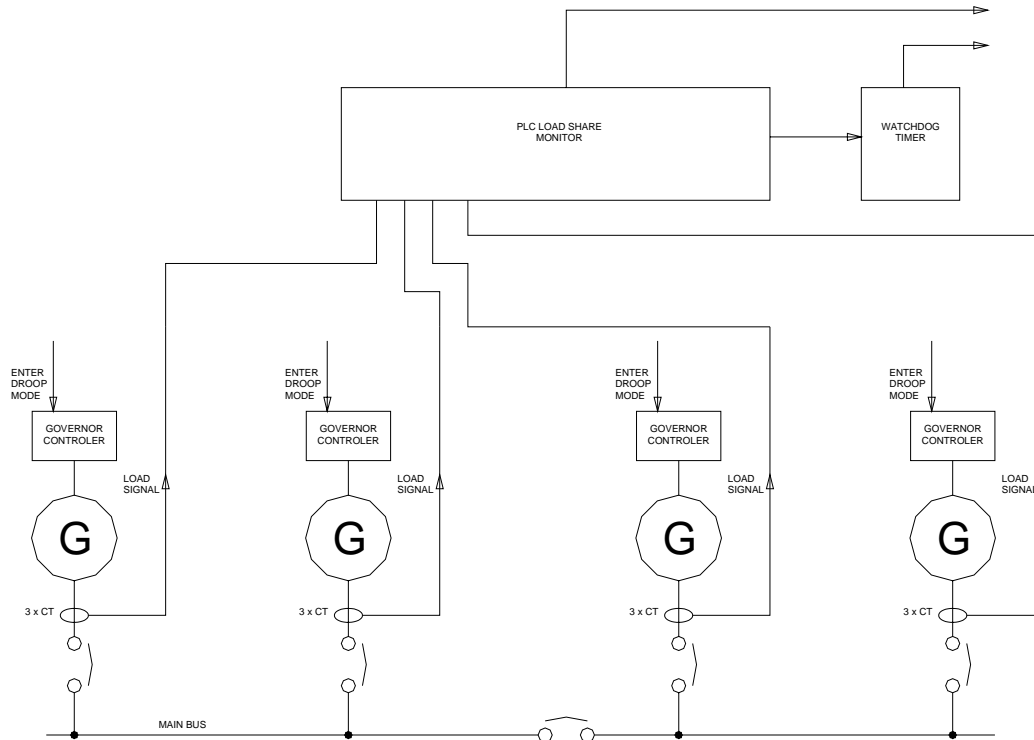

**Figure 8 Woodward 828 LON Monitor**

The Woodward 828 is essentially a 723 speed controller with the control firmware excluded. This gives the programmer the flexibility to devise control functions not included in the Woodward product range which can be seamlessly integrated with existing products in the range.

In this implementation the 828 is programmed to monitor activity on the LON bus. In the event of a short circuit on the bus, data activity will cease and the 828 will initiate the state necessary to command all governors in the network to enter droop mode. The basic concept is illustrated in Figure 8. The 828 is fitted with two LON channels and the programming may be extended to monitor two busses in a split bus DP Class 2 configuration.

## 6 PLC Based Load Monitoring



**Figure 9 PLC Based Load Share System**

This solution may be used in either analogue or digital load-sharing systems and in some aspects resembles a 'cut-down' version of the distributed VMS system described above in Section 4

A dedicated PLC may be programmed to monitor the loads carried by each genset. In the event that the load seen on any on unit exceeds a given window the PLC may command all units to enter droop mode. A failsafe watchdog unit monitors the operation of the PLC and can be used to alert the vessel staff in the event of PLC failure.

In devising such a system considerable attention must be made to programming of the tolerance window and load averaging. Speed of response to anomalous situations is also a critical factor.

## 7 An Economic Distributed Solution

OEM of Houston have developed a similarly cost effective solution to the issue. This approach was taken for the need for the provision of an economic load sharing scheme for offshore jack-up platforms, although it was recognised that the solution could equally be applied to marine propulsion and DP power plants.

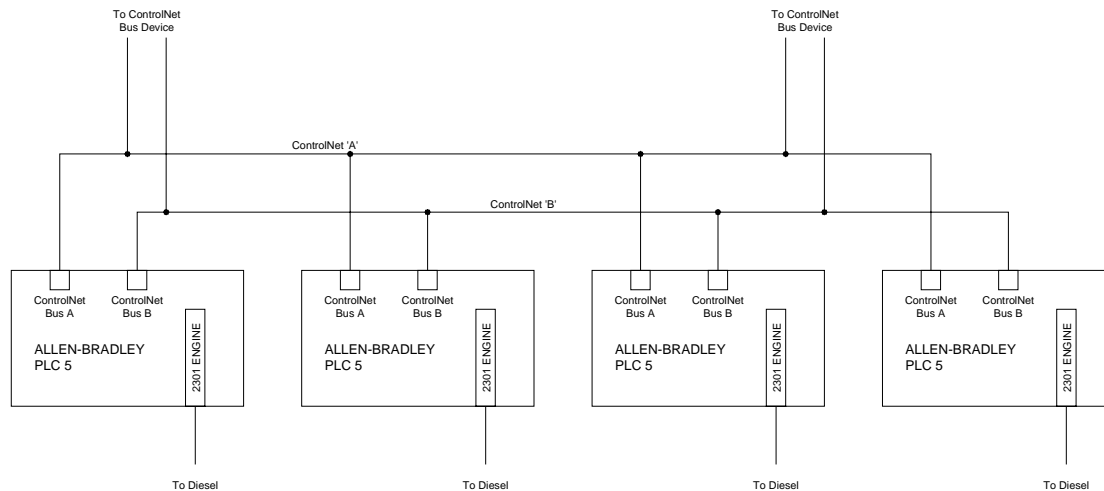

**Figure 10 Distributed Load Management, OEM**

The basic topology of the OEM solution appears similar to the distributed control networks described above (See Section 4 above) and although it may be used a part of a fully distributed network it has a number of advantages in designs where budget is a major consideration.

OEM have developed a Woodward 2301 series electronic governor engine which can be inserted in a standard Allen Bradley PLC5 series controller rack. The 2301 electronic controller is basically similar to the analogue controllers described above (Figure 4).

The PLC5 system may be configured with 'hot' back-up controllers and a redundant stable communications network thus giving a high level of redundancy compatible with the requirements of DP Class 2 systems. Theoretically, the worst case failure is the loss of either PLC backplane or failure of the 2301 governor engine card, resulting in loss of no more than one generator to the distribution network.

## 8 Hybrid Control

Legacy Automation Power and Design of Houston are currently developing a hybrid system which makes use of both analogue and digital techniques.

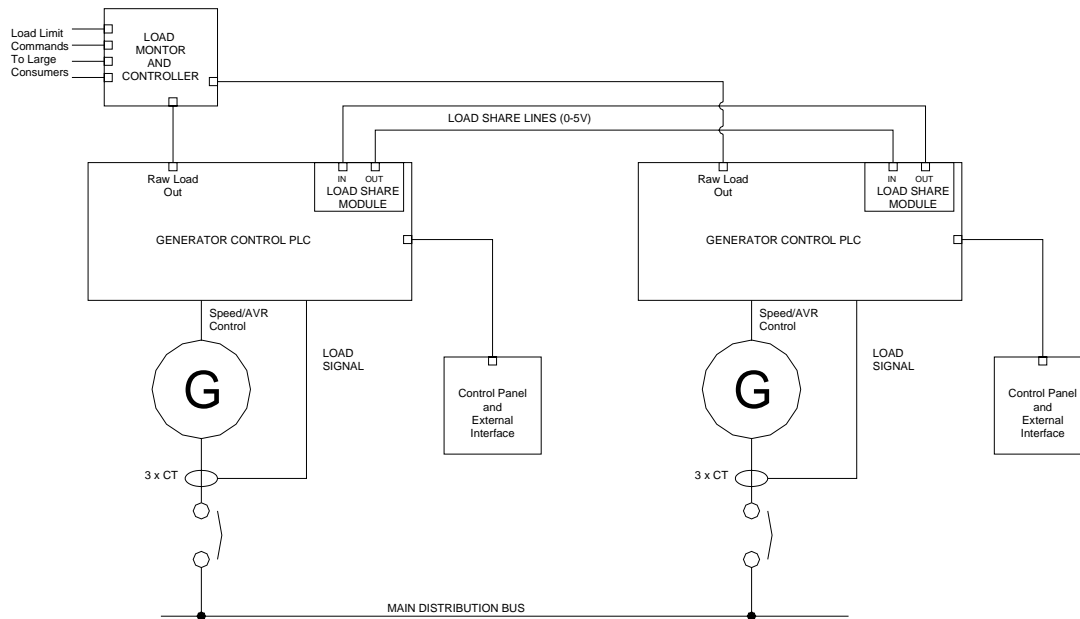

**Figure 11 Hybrid System, Legacy Automation**

The system combines governor, synchronisation, and loadsharing capabilities as well as external interfaces for use in a general power management scheme.

The system shown in Figure 11 is for a single bus system but can easily be expanded for multiple bus operation.

The loadshare line is arranged in a ring loop and is, therefore, resistant to any single open circuit within the loop. A short circuit on the loop will be recognised by the load share voltage level dropping to zero, the PLC controllers will respond to this state by entering droop mode control.

A bus dedicated load monitor and control unit takes in raw power data from all connected control PLCs and has the capability of reducing power consumed on all suitably equipped major consumers. This provision serves to enhance anti-blackout control in the main PMS.

## 9 Conclusions

At the current time, a number of solutions to the issues discussed are available to the designer and these should be considered on a case by case basis.

It is incumbent upon the designer to be aware of the burdens placed by the necessity to meet the requirements of DP Class and the inherent advantages and disadvantages of the various main topologies available.

### 9.1 Droop Mode

Droop mode of genset operation provides the highest level of failsafe operation in a power distribution network. However, since no two engines have identical reaction properties all droop controlled networks must be constantly monitored to ensure equal load distribution and to prevent accidental loss of any one unit due to over or under load conditions.

### 9.2 Isochronous mode

Isochronous mode ensures equal distribution of load across all connected units and permits individual load control of any one unit to permit temporary maximum loading conditions. These two factors permit a maximisation of load and maintenance efficiency which cannot be achieved in the droop mode of operation.

### 9.3 Analogue Isochronous Control

Pure analogue isochronous control contains inherent design flaws which preclude its use in DP Class 2 operations unless the implementation is specifically designed for split bus operation.

Split bus mode of operation in isochronous mode tends to negate the basic advantages of this design.

### 9.4 Digital Isochronous Mode

Implementation of digital solutions to load share and synchronisation has the potential of providing a cost effective solution to the issues involved in the design and operation of a modern diesel electric DP vessel. However, no design product range known to the authors has the necessary built in redundancy to permit direct implementation in a DP Class 2 load sharing and power management system without the inclusion of additional monitoring and control equipment in the system.

It is considered that, as long as the DP market remains a small percentage of the marine power management total market that little change will be seen in this field.

Of all the implementations discussed only two carry full Class Type Approval. Use of the alternate methods requires individual application for acceptance to the Class Society, this carries additional cost/time burdens to the project.

## References:

Design Considerations for Electric Propulsion of Specialist Offshore Vessels, Taylor and Williams, Institute of Marine Engineers, October 1984

Governing Fundamentals, Woodward Governor Company, Product Manual 25195

Barber Coleman Company, Basic Governing Information

In addition, the Author would also like to note the assistance of the following in the preparation of this paper:

Alstom USA, Houston

Kongsberg-Simrad USA, Houston

Gerhardts Inc. New Orleans

OEM Electric, Houston

Legacy Automation Power and Design, Houston