



DYNAMIC POSITIONING CONFERENCE
September 17-18, 2002

Power Session

Dynamic Positioning Incidents
Resulting From Inadequate Power Systems Analysis

Don E. Wilkes, P.E.

GlobalSantaFe Corporation (Houston, Texas)

ABSTRACT

Dynamically Positioned and other offshore drilling, pipe laying and mobile work platforms require dependable electrical power for operation, integrity of the well and safety – of both the installation and its personnel. Regulatory bodies review the design documents to ensure that the system is safe and predictable. Installations require larger and larger power systems but the limited availability of real estate demands that the space allocated for this equipment be kept to a minimum. Recent “improvements” in the design of circuit breaker devices used for system protection appear to simplify meeting the competing goals for safety ratings and space requirements. A closer look at the operational characteristics of these devices reveals a potential trap that could result in unexpected loss of essential services resulting from a circuit fault occurring in a power circuit serving a piece of non-essential equipment.

This paper looks at a typical large distribution system as might be found on a modern Dynamically Positioned vessel, with regard to the inter-relation between the different circuits in that system, and how improper use of these modern devices may cause these failures to propagate beyond the area that is anticipated. Evaluation of system distribution and approvals from regulatory bodies does not guarantee that the system will operate as intended. Some reasons for this will be proposed. Experiences from newly constructed drillships will be used to illustrate actual consequences from failures in analysis that allowed faults to spread beyond the device that should have protected the system from consequential results.

DYNAMIC POSITIONING INCIDENTS RESULTING from INADEQUATE POWER SYSTEM ANALYSIS

Operation of special purpose commercial offshore vessels requires that these vessels maintain a desired location. For vessels with purposes like pipe-laying or survey, this location is generally a track across the sea floor. For vessels with applications like oil well drilling the position is a fixed location relative to the sea floor. Other service vessels, such as Diving Support or Supply vessels fall into either category, depending upon the phase of their mission. In relatively shallow water the position can be maintained by anchoring the vessel to the sea floor using pilings, chains or other passive methods. For vessels using these methods, loss of power may terminate operations, but the vessel position is not in jeopardy. As the water depths increase, these passive methods to maintain location are no longer practical. For these deeper locations vessels use on-board power generation to maintain location by Dynamic Positioning. With these systems loss of power, or even inadequate power, will cause loss of the capability to maintain the required location. Partial loss of power in some of the distribution system may result in extensive loss of capability. The loss of this capability can further jeopardize the safety of the vessel and its crew.

The vessels in operation today are complex systems, requiring electric power to perform the majority of their energy application. Even vessels that use direct mechanical propulsion have requirements for reliable electric power for propulsion system controls or for use in other systems on the vessel. The problems we are going to discuss today that can create incidents for DP Vessels can create similar problems in vessels that do not use DP.

Because of the need to have a reliable power source to supply the propulsion, scientific, or industrial systems as well as power distribution for normal vessel usage, the design of the electrical systems has been improved over the last several years. Whether or not systems are certified to be DPS-2 or DPS-3 qualified, the system configuration is being sectionalized to eliminate total system failures as the result of a single fault or component failure. When the mission is critical the systems will be subjected to a Failure Mode and Effect Analysis to establish the integrity level of the system design and its implementation.

Some of the simplest evaluations include an analysis of the feeder and branch circuit configurations to determine which loads will be impacted by the loss of a significant component in that system, such as a transformer. Most vessels, and certainly DP vessels, will have more than one of these critical components, both because of the power levels and to provide redundancy. The distribution will be configured to provide alternate power sources to equipment that is redundant. Again, this is a part of the review that is included in an FMEA.

Another system design area that should receive more attention relates to the auxiliary power or control power sources that are required to permit operation of essential equipment. These systems are part of the evaluations, but usually the criteria applied allows a greater degree of failure than might be achieved with little additional effort or expense. If the loss of equipment resulting from a single failure is no greater than, for example, the loss of an engine room, such a failure is itself considered acceptable. Multiple power sources and wiring configurations that are not optimized are examples of this problem.

Regulatory bodies impose certain requirements on system designs to increase reliability of critical systems, and require that some loads be supplied by emergency generators. In most instances these agencies are concerned more with safety issues than with operational or economic issues. Even with vessels that are certified for DPS classifications, the primary concern is safety of the vessel and crew, and not the economic impact that may result as a consequence of a failure.

Dynamic Positioning incidents occur when a system or component failure causes a reduction of system redundancy to the extent that there is an impact on vessel operations. Often times the cause of these incidents is difficult to pinpoint. When a cause is determined the source often lies within systems that have been reviewed.

A typical basic Power System arrangement is depicted in the following diagram noted as Figure 1.

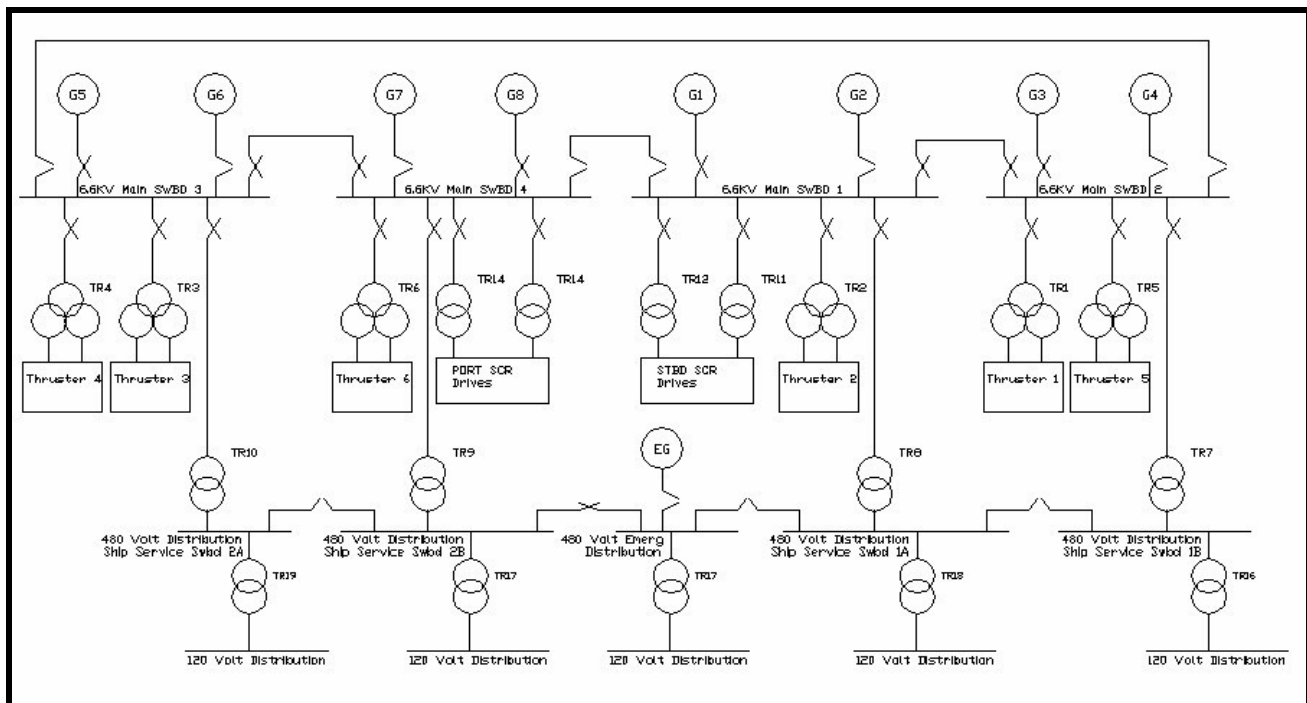

Figure 1

Note that there are four separate systems that may be operated individually or in a variety of combinations of these buses. An Emergency generator is also a part of low voltage distribution system. Details of the distribution are too complex to be incorporated here, but there are some features that deserve comment. The vessel has been classed as a DPS-3 vessel, arranged as two main engine rooms with auxiliary systems and propulsion systems arranged to support a dual power system arrangement. For this vessel typical operation is as a split power system with two HV busses but four LV busses to provide what is considered to be maximum reliability.

The support systems needed to operate the prime movers include redundant pumps for each system, operating with one on standby, and the power for the multiple pump motors is supplied from different LV busses including the Emergency distribution bus. With the arrangement it is easy to look at the distribution system and identify the equipment that would be unavailable if a transformer or major feeder circuit were to fail.

With all of these safeguards, how do you have a relatively minor failure result in sufficient loss of distribution that a DP incident results? Let's examine some instances that have occurred.

In one occurrence a blackout occurred on a drillship that is of a similar system design. In this instance the vessel was operating in a single bus configuration. The problem was determined to have been caused by noise on one of the control signal lines being supplied to one of the engines, causing it to trip off line. A full blackout resulted, but the reason for extension of the fault to the full blackout was not publicized.

Another example is an occurrence I also discussed last year. That particular problem occurred as a result of multiple failures, but ultimately because of the engine protection system. A simplified block diagram is shown in Figure 2.

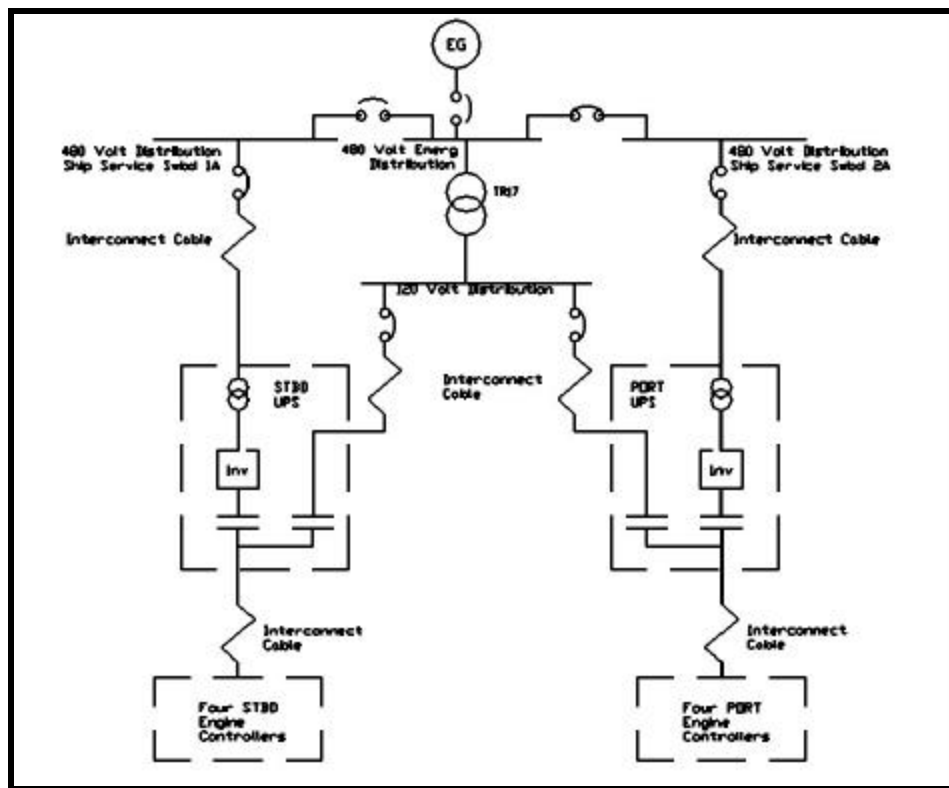

Figure 2

The UPS's had both failed and were operating in Bypass mode, supplied from alternate emergency distribution. During a routine weekly test of the emergency generator the emergency distribution tripped off and controls for the engines shut off the propulsion loads for the entire ship. This susceptibility was not identified in reviews prior to the event.

The power sources, protection and support systems must always be included in a failure mode analysis.

Several incidents have been reported in various types of DP vessels in which a UPS system was a significant contributor to the failure and the resultant incident. I believe the name given to the equipment gives a false sense of security about any system that incorporates this equipment. The equipment employs and requires batteries to permit them to function. Too often the system for maintaining proper battery charge is not properly implemented to provide alarms and a power problem is only announced when the batteries have discharged. Loss of primary power must always be alarmed to allow time for reaction and alternative action to be taken prior to discharging the batteries. Proper preventative maintenance for any system with batteries should include periodic verification of the alarm system, and status of the battery charge by operating on battery power to support the system loads for an adequate length of time.

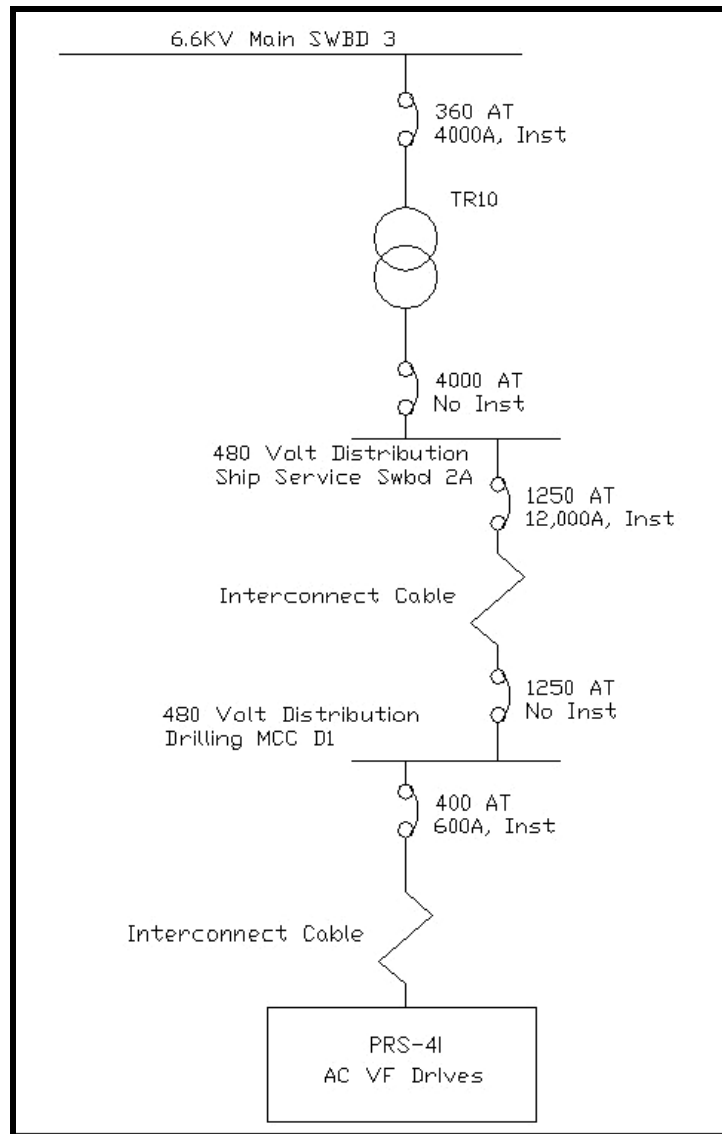

Figure 3

Figure 3 is a portion of the distribution one line that includes equipment involved in another incident. In this event a short circuit fault in the Drill Floor Pipe Racker resulted in tripping of the entire MCC that was supplying about 25% of the drilling equipment. Although the position keeping equipment was not a part of this power loss, one mud pump was lost, which could impact well control capability in critical situations. And there are similar circuits for other equipment that would result in loss of position keeping machinery were a similar fault to occur in those circuits.

Even though power was reestablished in relatively short order, the power system analysis predicted that such a fault should have been limited to that specific load involved in the fault. There is an ABS regulation that requires that faults be cleared by tripping of the nearest upstream circuit breaker.

The 400 Amp circuit breaker feeding the pipe racker included an Instantaneous trip set to about 600 Amps, and the feeder circuit breakers on both ends of the interconnect cable from aft to forward were 1250 Amp circuit breakers, and only one of them had its instantaneous trip enabled, at about 12,000 Amps. Which breakers tripped?

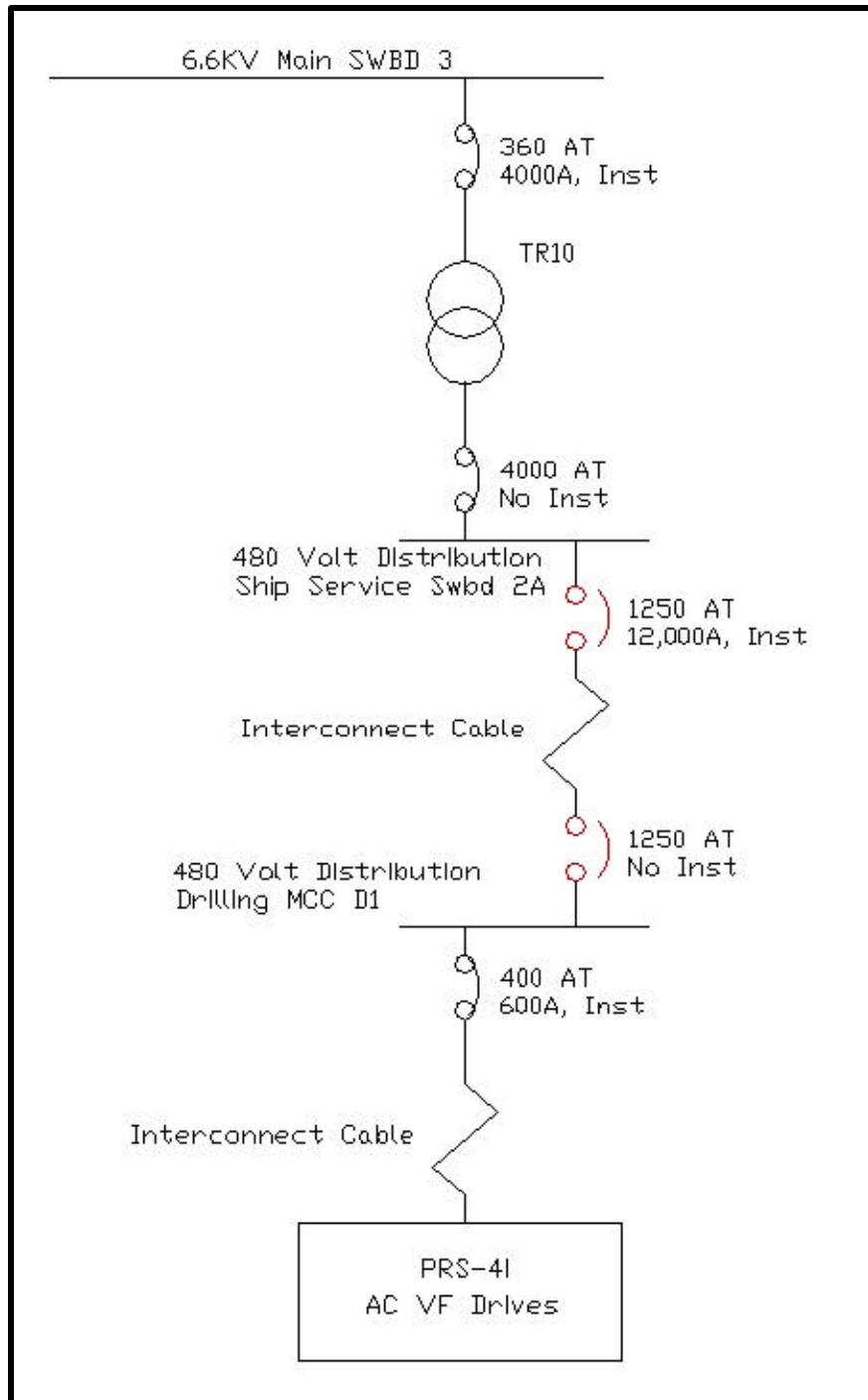

Figure 4

The answer may seem surprising – both 1250 Amp breakers, as highlighted in Figure 4. The 400 Amp breaker remained closed. When the supply breakers were reclosed while attempting to restore power, the 400 Amp breaker did not trip! How could two 1250 Amp circuit breakers trip, one of which even had its instantaneous trip element switched off, and a 400 Amp breaker with a 600 Amp instantaneous trip remain closed? The cause of this problem will be discussed later.

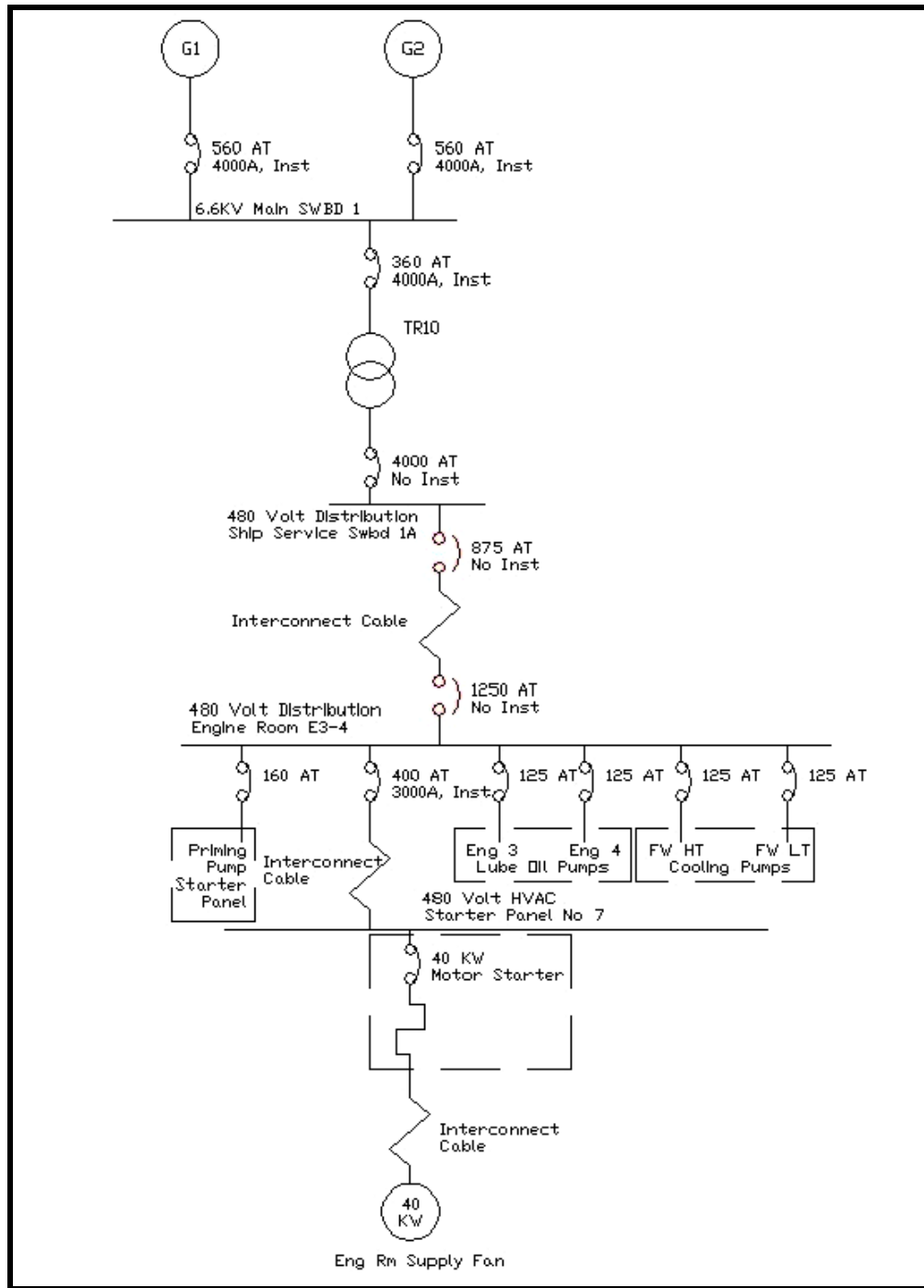

Figure 5

Figure 5 is another portion of the distribution on the same ship. In this segment of the distribution, there are two distribution boards that are sub-feeders from the main Ship Service LV Switchboard. Note also that E3-4 is the engine room distribution board that supplies auxiliary equipment specific to Engines 3 and 4, along with some of the auxiliary systems for all of the Starboard engines. It is supplied from the main LV switchboard through an 875 Amp circuit breaker that did not have an instantaneous trip enabled. A 400 Amp circuit breaker in E3-4 supplies an HVAC distribution MCC that operates one of the Engine Room fans. The fan happens to be a 40 KW two speed fan. Most of the time this fan is on low speed, but at heavy loads on the engines the speed may be increased to improve heat removal. When this motor

shorted, the 875 Amp circuit breaker feeding E3-4 opened and removed the fault from the system. However, at this time only engines 3 and 4 were supplying power to the starboard bus, and when their auxiliaries were shut down the entire starboard side blacked out. All because of a shorted fan motor three levels down in the distribution. Why didn't the motor starter disconnect and prevent the wider blackout? Or why didn't the intermediate 400 Amp breaker trip to protect the E3-4 Distribution board? Initial investigations showed that the magnetic trip (or short time trip) for this 400 Amp breaker had been cranked to maximum – about 4000 Amps, whereas the drawings reflected a setting of 600 Amps for that trip. With the several loads on that HVAC along with the two speed motor it is apparent that the documentation was in error. The starting current for the motor, especially in high speed, would easily approach 250 to 300 Amps. It was concluded that, during commissioning, this breaker tripped when starting the motor in high speed. The solution was typical for startups – crank it up to where it won't interfere. When the motor was replaced and the trip was set back to the documentation level, it did indeed trip when the motor was started. An intermediate level of about 1200 Amps was selected as the setting. But this still left the question unanswered as to why the motor starter didn't provide adequate protection in the first place. The answer to this question turned out to be the same as the previous problem.

How could these happen? ABS had reviewed and approved the distribution system. The vessel had a DPS-3 classification. To improve the confidence in the reliability of the system, in addition to the analysis provided by the builder upon which the ABS reviews were based, the owner had an independent FMEA analysis performed. And the client for one of the two identical ships had another third party consultant review the findings of the two FMEA's. None of these hinted at the problem that was the root cause here. Note that in these failures the reliability level provided by the DPS-3 capability was not compromised, but these were DP Incidents. And a lot of time was spent in researching the issue and making repairs.

Circuit breaker data with selectivity and coordination curves had been a part of the data submitted to ABS. These all indicated proper discrimination between the various breakers. Based upon these curves such incidents could not occur – but it did, and it was repeatable. After review by the manufacturer the problem became apparent.

As is characteristic of most new ships the loads are getting larger, generators are larger, and as a result fault current levels are increasing. To be on the safe side, the owner had specified that all equipment be rated to interrupt fault current levels higher than were likely to be present, to allow for load growth and early equipment procurement. It also permitted lower impedance levels for the power components, likely to lower the THD that would result from operation of harmonic generating rectifiers on the power system.

To achieve this higher interrupt level, the manufacturer had used Current Limiting circuit breakers. Most suppliers offer this type of circuit breaker to achieve the higher interrupt ratings needed for these larger distribution systems because they fit within smaller envelopes and allow them to offer a competitive solution. But the way these breakers work contravenes the operation depicted by the curves these same manufacturers use to describe their performance. Interrupting a current of 75,000 amps requires a much larger volume and arc length than interrupting a current of 40,000 or 50,000 Amps. And space is always a precious commodity. That's where Current Limiting breakers come into play.

These breakers take advantage of another modern convenience – computer power, along with fast operating mechanisms. Using fast processing, the current waveform is continuously monitored and the rate of change of the current (di/dt) is calculated, providing sub-cycle control of the mechanism. A fault current of 75,000 Amps may have a peak value approaching 200,000 Amps, including asymmetrical components or DC offsets. If the di/dt for the current waveform indicates the current might reach these high values, the breaker is tripped very quickly – long before it reaches these destructive levels. Thus in the presence of high fault currents, these breakers WILL open in five or ten milliseconds.

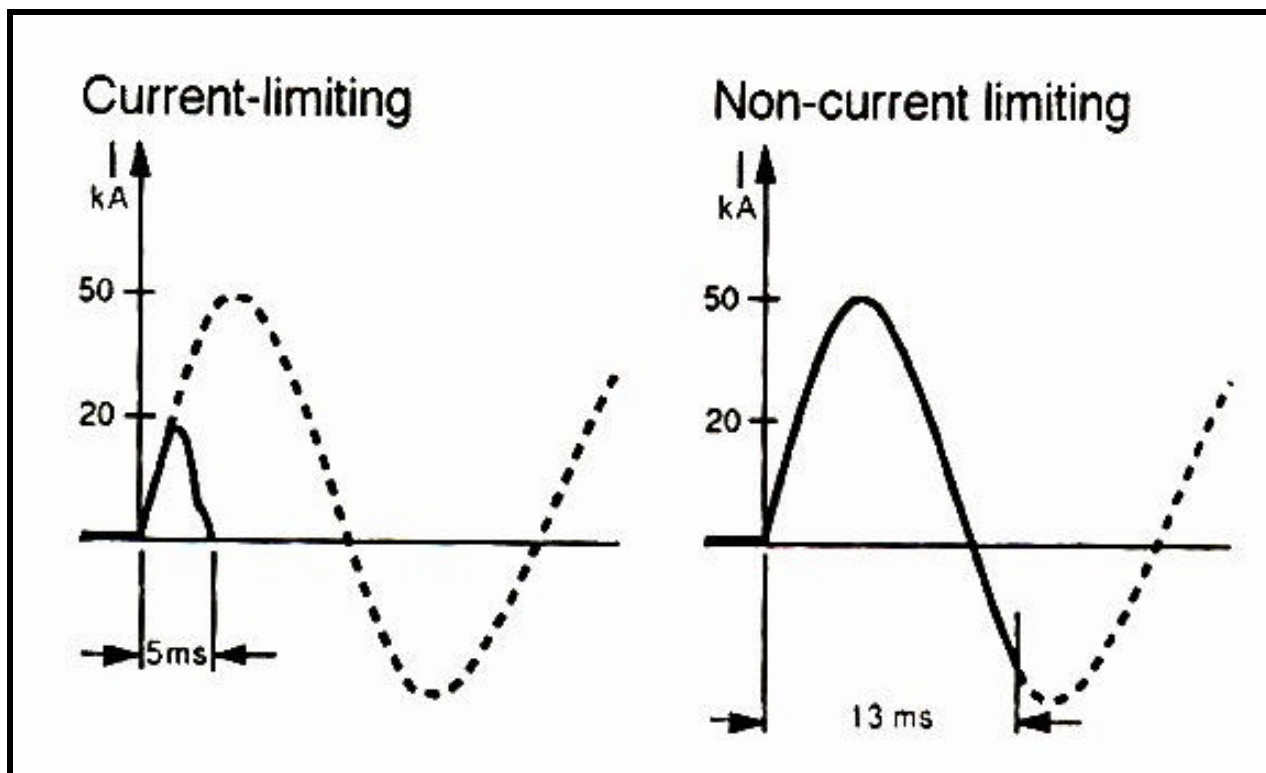

Figure 6

This trip characteristic is present whether or not the Instantaneous trip function is enabled. It MUST trip in this manner, because it cannot interrupt the high currents that would occur in the presence of a major fault just a few milliseconds later. This allows the smaller breakers to be used in applications requiring high fault capabilities.

Because a breaker employing current limiting techniques actually opens on the basis of *predicted* current levels, circuit breakers that are in series in the fault circuit will predict the same current level and all are likely to protect themselves by opening their mechanism. Similarly, breakers that are in series fault circuit that do NOT employ the predictive techniques and operate on the *actual* current levels will not trip as a result of the fault because the current limiting breakers will open before the fault level reaches the energy level associated with even an Instantaneous trip characteristic. Even when all breakers may use predictive techniques, different models of breakers may use trip devices that have different predictive techniques. Larger breakers typically have more space available to permit installation of a trip device with more computational power. User expectations may also dictate a more sophisticated trip unit for the insulated case or metal enclosed breakers than for the smaller molded case size circuit breakers.

In the example described above, both the 1250 Amp Breakers and the 400 Amp breaker were current limiting but different models. The 400 Amp breaker remained closed and both 1250 Amp breakers tripped, likely because they were different models of breaker with different characteristics of the predictive trips.

Similarly, the 875 Amp Breaker and the 400 Amp breaker in the third example were different models of current limiting breakers, while the motor starter controls operated on actual currents.

When a distribution system incorporates breakers that are activated by the di/dt current prediction methods, additional techniques must be employed to establish the selectivity of the breakers in the various distribution systems. In many cases the necessary selectivity cannot be established when these breakers are used.

If you look back at Figure 5, another common fault is exemplified. In the particular event in question the resulting blackout in the starboard distribution occurred because the lube oil pumps supplying the engines that were operating were supplied from the distribution board whose supply breaker tripped due to the fault. Note however that the source of power for the board is actually derived from the switchboard fed from Engines 1 and 2. Thus, with the same engine configuration, any fault that caused the tie breaker between the two Stbd HV switchboards to open, power to the board that supplies the operating engine auxiliaries would be lost. A more optimal implementation would have loads supplied by the sources they serve. In this particular instance the fault that might result from such a failure would not create a failure more serious than loss of the full engine room so there was no specification basis to exact a modification from the builder.

Why do these problems escape the review of regulatory bodies and engineers?

1. The contractual arrangements for regulatory review are generally not conducive to extensive review or analysis
 - a. Many approval contracts are competitive.
 - b. New construction contracts typically include the cost of the review, and builder doesn't gain from identification of problems.
 - c. Delivery requirements complicate review.
 - d. Incomplete or inaccurate documentation is supplied for the review.
2. Information supplied for reviews may not fully or sufficiently define the equipment to identify the problem.
3. Circuit Breaker curves do not depict the predictive tripping characteristic of current limiting breakers.
4. Regulations have not been updated to reflect the characteristics of UPS equipment.
5. Design is not completed in time to review prior to construction.
6. Problems identified late in process may not be corrected due to cost or schedule.
7. We screw up.

How can we improve the situation?

1. Learn from mistakes, especially our own, and share them with others.
2. Learn from the incidents that occur.
3. Don't accept an explanation for an incident if the supporting information conflicts with the explanation, or the basis is flimsy.
4. Improve specifications to require optimal configurations, not just meet regulations.