



**DYNAMIC POSITIONING CONFERENCE**  
September 18-19, 2001

---

**THRUSTER SESSION**

---

**A Thruster System which Improves  
Positioning Power by Reducing Interaction Losses**

---

Mr. Leif Vartdal and Mr. Rune Garen

*Rolls-Royce Marine AS,  
Ulsteinvik, Norway*

## Introduction

Rolls-Royce has delivered propeller and thruster systems to several hundred vessels which have dynamic positioning (DP) and dynamic tracking (DT) systems. These deliveries cover many different types of vessel with various degrees of complexity and comprehensiveness, both with regard to thruster type and thruster configuration.

The main task for the thrusters is to transform the power from the propulsion motors to thrust. For power to be transformed into thrust and positioning ability in the most effective way, it is necessary that the thruster itself has a high thrust per unit of power input and it is also vital that the thruster type configuration and the hull form are chosen with a view to reducing thrust losses.

Since the 1980s, from model tests carried out at NSFI/Marintek, understanding of losses in thrust and torque/power caused by thruster to thruster and thruster to hull interaction has been built up, and with it the ability to quantify matters. The results of these experiments show that these interaction losses are very dependent on both hull geometry and thruster placing.

This paper presents the results from cases where, with the help of simple modifications to thrusters, it has been possible to influence thruster-hull interaction losses to a significant degree.

An Ulstein Aquamaster thruster type known as Combithruster is also presented. This thruster system provides the functionality of an azimuth thruster and at the same time can be used in tunnel thruster mode. The paper presents results from model tests, which show how this type of thruster can be adapted to the hull to limit various types of thruster loss.

Thrusters can be a critical source of noise, and in recent years there has been a steadily increasing focus and tougher limits on noise in accommodation spaces and cabins. Noise requirements can come from maritime authorities, operators, ship owners and organizations representing the interests of seafarers.

## Thruster and propeller system – concepts, with guidelines for determining power requirements

Combinations of several types of propeller and thruster installations are often used to generate positioning forces on a vessel. Distinction is often made between the following systems:

1. main propellers,
2. tunnel thrusters
3. azimuth thrusters.

A combination of these propulsions systems can form part of the DP or DT system on the same vessel. This is often the case with shuttle tankers and supply vessels which operate for much of the time in the free running condition but with a DP requirement. Vessels such as semi-submersibles, drill ships and production ships, which mainly operate in DP mode are, in many cases, equipped solely with azimuth thrusters.

A distinction is made between open and nozzle propellers both with regard to main propellers and to azimuth thrusters. Nozzle propellers are, as a rule, selected for most DP and DT applications, since the nozzle increases the thrust by 15%-30% compared with an open water propeller in the low speed region of less than 5 knots.

In determining the power requirements for thrusters and propeller systems it can be useful to form an idea of how much engine power must be transferred to the various systems to obtain a given thrust in the DP speed range of 0 to 2 knots.

Specific thrust, which has the dimension power per unit of thrust (for example, Newtons per watt or kN per kW) are given below for various systems. Since this value is dependent on propeller diameter and revolutions, specific thrust varies within each system as the summary below shows.

The figures given are exclusive of power losses such as interaction losses, air sucking and so on. They are, nevertheless, useful for giving an idea of the power requirements for various systems in an early phase in the project once the natural forces acting on the vessel are known.

<b>Type of thruster/propeller</b>	<b>Specific thrust (N/W)</b>
Tunnel thrusters	0.12-0.16
Fixed thrusters with symmetrical blade profile and nozzle	0.14-0.16
Open propeller with blade geometry for predominant thrust direction and turning sense	0.13-0.15
Nozzle thruster/propeller with nozzle and blade profile designed for the predominant thrust and rotation of the propeller	0.16-0.21

Rune Garen, Rolls-Royce Marine AS      Thruster      A Thruster System which Improves Positioning Power by Reducing Interaction Losses

---

It can be seen from the table that the nozzle thruster where the propeller and nozzle are optimised for thrust in one direction is potentially the most effective system for converting engine power into thrust. If the thrust direction is changed by 180° without using the azimuth function on such a thruster, that is either by changing the rotation sense of the propeller where a fixed pitch propeller is used or by moving a CP propeller to negative pitch, research shows that the thrust will be reduced by between 20% and 50% dependent on propeller geometry and nozzle shape.

Both tunnel thrusters and azimuth thrusters with symmetrical nozzles have symmetrical profiles, the reason for this is the desire for the same thrust to port or starboard (alternatively ahead and stern). But, as can be seen from the above table, there is a sacrifice in specific thrust where symmetry is desired.

Because of the symmetrical profile of the blades, tunnel thrusters give significantly more cavitation noise than thrusters which have the blade geometry optimised for a particular direction of rotation and thrust. This is discussed more fully in the section on the Combithruster.

## **Tilting of the nozzle – its effect on thruster-hull interaction on a semi sub**

The speed and direction of the propeller flow is important for thruster-hull interaction and thruster to thruster interaction. Theoretical and experimental studies of propeller flow physics both in open water and interacting with adjacent hull surfaces are being carried out in several contexts (e.g. refs 3, 4 and 5). In practice it is possible to influence interaction losses for azimuth thrusters in the horizontal plane by altering the angle of the propeller race by altering the azimuth angle.

It is often desirable or necessary to be able to control the propeller wash in the vertical plane. In this connection, Rolls-Royce has experience of an effective practice which is to angle the nozzle so that it makes a small angle to the horizontal.

Model testing was carried out in the middle of the 1980s with two different platforms (ref. 6 and ref. 7) which demonstrated reduced losses and therefore, increased positioning power in the azimuth sector where the propeller flow was directed towards the opposite pontoon, when the nozzle was tilted down by a few degrees so that the propeller wash was directed downwards. In the absence of any way of deflecting propeller wash downwards, interaction losses as high as 45% were measured. The platforms in question had thruster assisted mooring and were equipped with four thrusters, one in each end of each pontoon.

In 1997 Ulstein Propeller (now part of Rolls-Royce) received an order for eight azimuth thrusters for *West Venture 2*, a so-called fifth generation platform which can hold station under DP using only thrusters.

To determine interaction losses between thrusters and platform and between adjacent thrusters, model tests were carried out at Marintek on behalf of Ulstein Propeller in co-operation with Smedvig and Hitachi Zosen.

## **West Venture – model tests with thrusters and platform**

Prior to model testing at Marintek, research was carried out at the Danish Maritime Institute (DMI) which concluded that each thruster must develop a thrust of 55 tonnes (539.6kN) at zero speed to balance the external forces under weather conditions corresponding to a wind speed of 33m/s. From this starting point, thruster type, required motor power, propeller diameter and propeller revolutions were determined. The required power from each thruster motor was estimated at 3,200kW for a 3.2m dia propeller turning at 212rpm in a NSMB 19A nozzle.

As part of the contract with the shipyard, it was required that Ulstein Propeller should guarantee the thrust of 55 tonnes. To verify this, a thruster model with a scale of 1:12.8 was made and then subjected to stand alone tests. The tests showed that the 55 tonnes of thruster were reached with a small margin but with a somewhat 'light' propeller. This means that the propeller absorbed less than the motor torque corresponding to 3,200kW at the nominal rpm. This was, nevertheless, accepted by the shipyard since the motor in this case could be operated with allowable overspeed and a mere 2rpm extra at the propeller gave the required nominal thrust at zero speed. Fixed pitch propellers are normally designed to be a little 'light' so as to have a margin against future fouling, something which causes the propeller to become 'heavier'. In addition to the test with forward thrust, that is positive propeller rotation direction, trials were also made with negative thrust, that is reverse direction of rotation. At zero knots, the bollard condition, only 55% of the thrust at the torque and speed corresponding to 3,200kW was achieved relative to forward running. This corresponds closely with experiments carried out using Kaplan propellers in the same nozzle profile. Behind the requirement for a particular thrust lay the assumption that thrust losses were 15% around the whole azimuth circle.

Because the parties were interested in seeing how this assumption applied to this platform and at the same time wanted to see how tilting of the nozzle affected interaction losses, a model of the platform was built

to 1:32 scale. The draught of the platform under test conditions corresponded to 23.5m at full scale. The illustration shows the model in Marintek's towing tank. Two model thrusters were installed in one end of one pontoon and driven by bevel gears and electric motors, which were mounted above the platform as seen in the upper right hand corner of the picture. The thruster propellers in the model were run at high

## Model of "West Venture" in scale 1:32

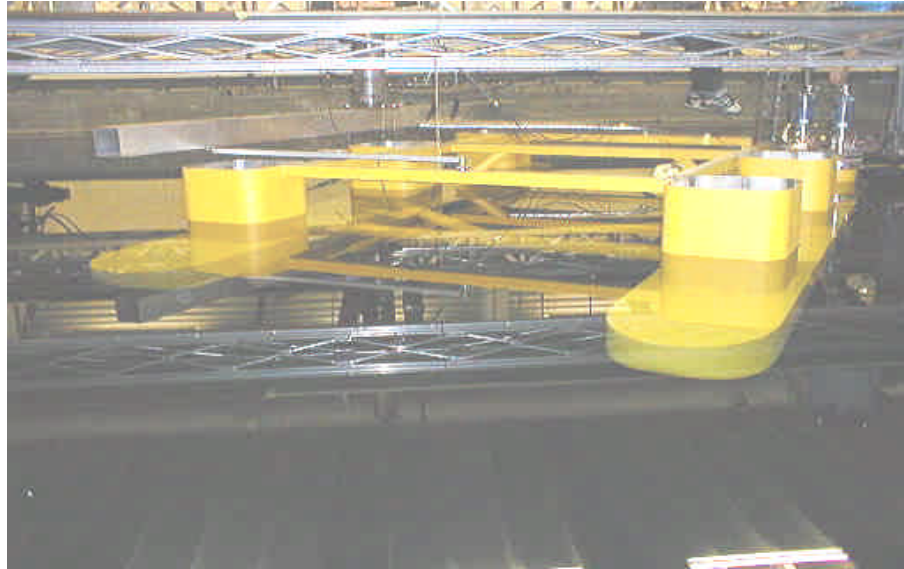

speed to give a turbulent propeller flow with the smallest possible scale effect and at the same time give the strongest possible signal to the dynamometer. Figure 1 shows the arrangement of the platform, location of the dynamometer and definition of forces and directions.

The following parameters were measured:

**K<sub>x</sub>** -force acting on the platform in the x direction

**K<sub>y</sub>** – force acting on the platform in the y direction,

**T<sub>1o</sub>** - thrust from thruster number 1,

**T<sub>2o</sub>** - thrust from thruster number 2.

The thrust from thrusters 1 and 2 was measured as each was turned to an azimuth angle where there was almost zero interference with hull or adjacent thruster. The sub suffix 'o' for T1 and T2 therefore show the free condition.

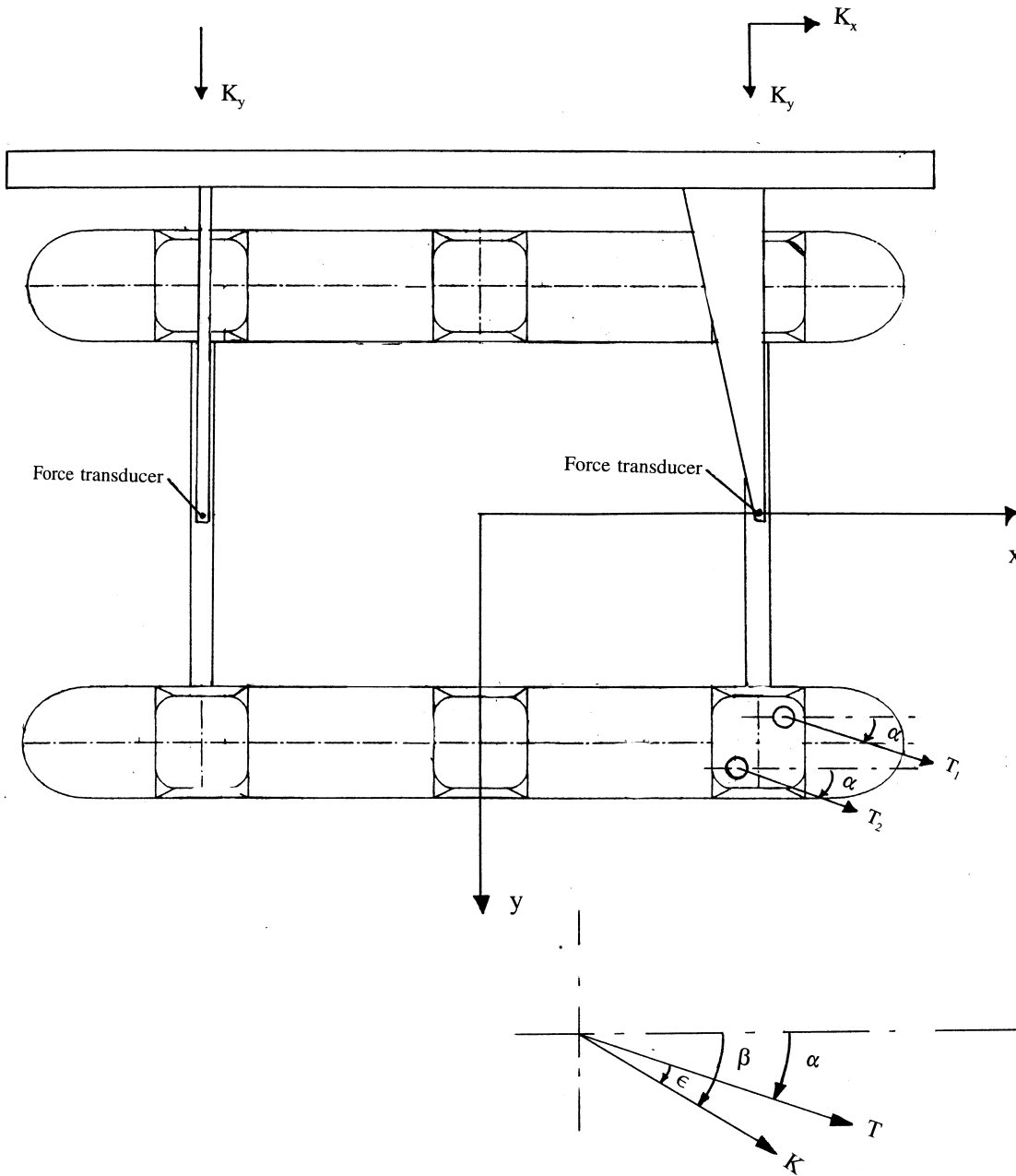

- $K$  = Total force on the platform
- $T$  = Total thrust =  $T_1 + T_2$
- $T_1$  = Thrust force from thruster 1
- $T_2$  = Thrust force from thruster 2

Fig. 1

Measurements were made for different azimuth angles and to establish a measure of interaction losses, the following force coefficients were defined:

$$CT(\mathbf{a}) = \frac{K(\mathbf{a})}{T_{1_0} + T_{2_0}}$$

A high CT value implies that the positioning forces are high and that the interaction losses are low. When CT is 1 it implies that the forces on the platform are the sum of the thrusts from the two thrusters and that interaction losses are therefore zero.  $\mathbf{a}$  designates azimuth angle for the two thrusters and  $\mathbf{K}(\mathbf{a})$  is the resulting force for the azimuth angle in question.  $\mathbf{e}$  is the angle between the thruster's force direction and the direction in which force acts on the platform. Tests were carried out both with the thrusters at the same angle at various different azimuth angles for the two model thrusters. For the tests with thruster angles synchronized, the tilt angle of the nozzle was varied from 4° to 6° to 8° relative to horizontal.

Figure 2 shows CT for the full circle and for three nozzle tilt angles. It is worth noting that the relatively large difference in CT over the sector corresponding to 30° to 110°. This sector corresponds with the region of the whole azimuth sector where propeller flow from the thrusters is directed against the opposite pontoon.

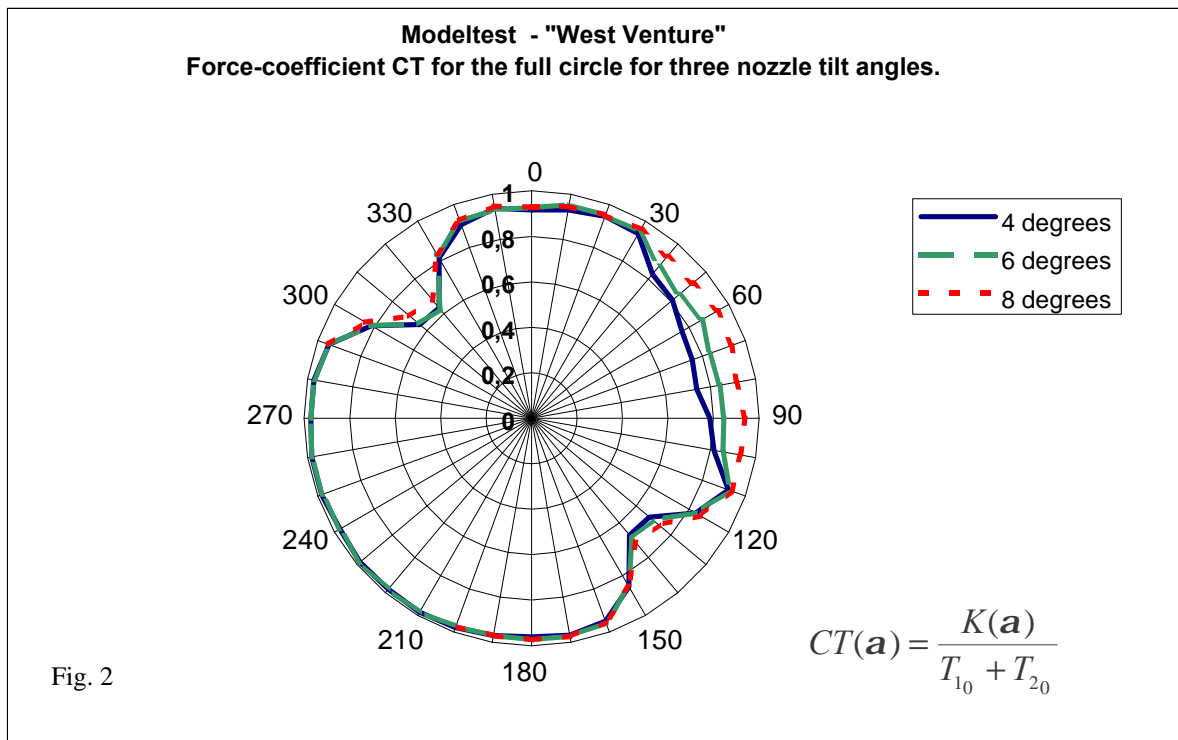

With a 4° tilt, the maximum thrust loss is about 28% while with 8° of tilt angle on the nozzle the loss is reduced to only 4% to 6%. Figure 3 shows what happens in this case. The Coanda effect leads to the propeller stream being bent around the bilge of the pontoon and as it swings upwards an additional drag force is experienced on the opposite pontoon. This force is in opposition to the thrust. When the nozzle tilt angle is increased and the propeller race directed more downwards, the Coanda effect reduces and therefore the force from the propeller wash against the opposite pontoon also reduces.

Figure 2 shows also a marked change in CT value in a relatively small sector at about 135° and 315°. This is caused by thruster to thruster interaction where the race from thruster number 1 blows into number 2 and vice versa. Here the losses are 30% to 40% and one can see that there is little difference between the three nozzle tilt angles. In these sectors, force measurements were also carried out with differences in azimuth angle on the two thrusters. With a 20° to 25° rotation of the upstream thruster the CT value rose to about 0.9. This agrees with the work done in reference 2. Normally the DP algorithm has a limit put into it so that the neighbouring thrusters do not direct propeller wash into each other over the critical sectors.

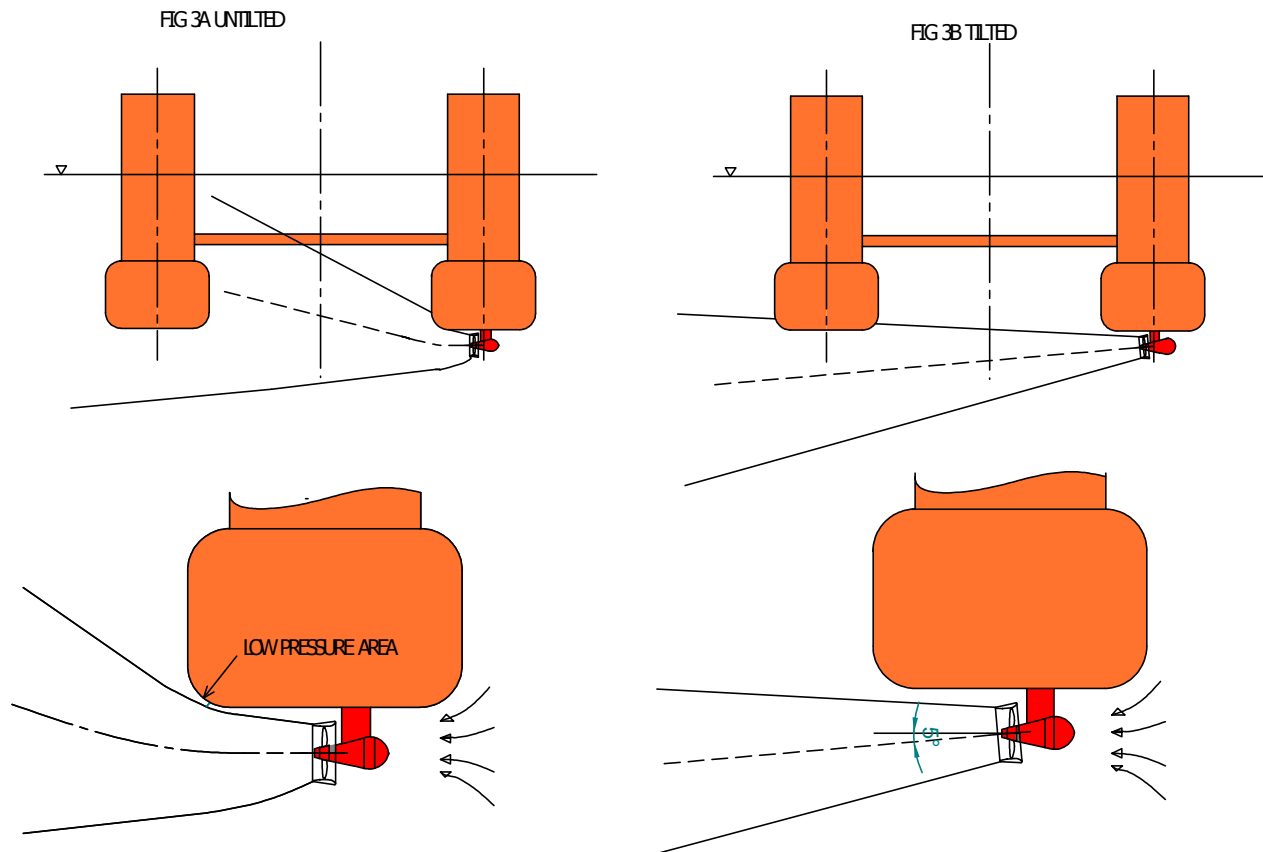

Figure 3a-b

In evaluating the loss of positioning force or CT as given above, no account is taken of the fact that the thruster in itself gives reduced efficiency as the tilt angle increases. At the same time as the total CT increases with increased tilt angle on the nozzle, so the efficiency of the thruster itself reduces. This was researched under the free trial condition with the 1:12.8 scale thruster model which was operated with both 4° and 8° nozzle tilt. Such a comparison must be based on merit coefficient, which is an expression of the thrust/output conditions at constant propeller diameter and motor output. In Figure 4 the reduction in merit coefficient is plotted together with the increase in force coefficient (0° tilt angle was not tested in this phase but instead data was used from the research in refs. 6 and 7). The value of thrust coefficient is, in this case, averaged over the complete azimuth circle from 0° to 360°. As shown in Figure 4 the increase in effectiveness is greatest at 8° nozzle tilt and at this point the reduction in merit coefficient is only 2%.

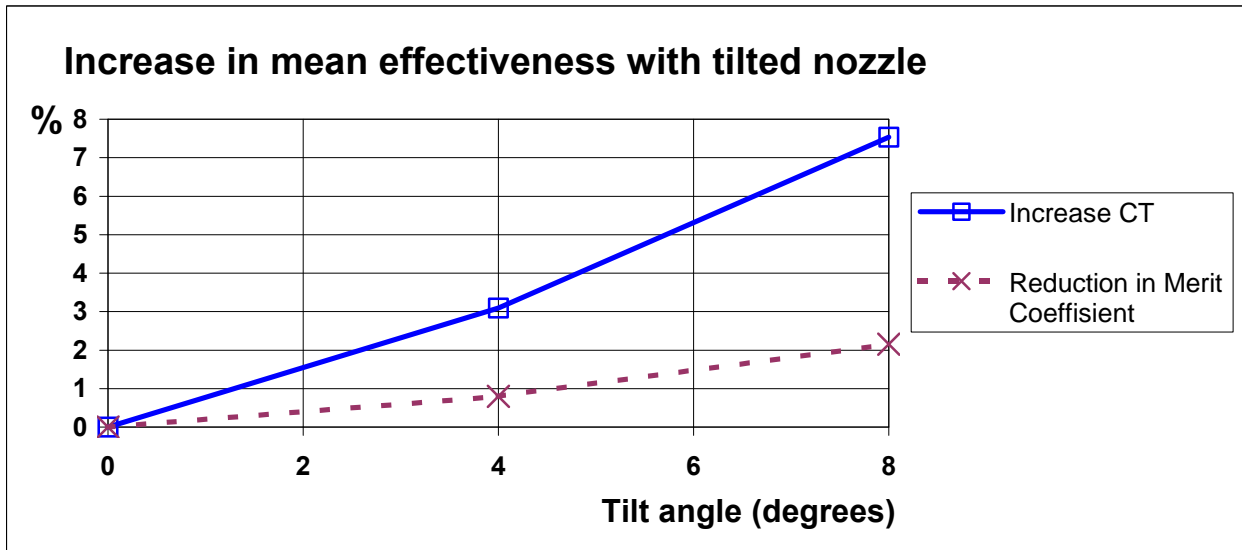

Fig. 4

Based on these results, it was decided that the nozzles should be mounted with an 8° tilt angle on each of the eight full size thrusters delivered for *West Venture*.

## Combithruster

In 1999, the former Ulstein Propeller introduced a new concept which received the name Combithruster. This product and its development was described fully in reference 9.

Combithruster in this context implies a combination of the advantages of an azimuth thruster with a nozzle and a tunnel thruster. One advantage of the tunnel thruster which is taken care of in the Combithruster is that it can be used in shoal water because of its location within the hull. It is often impossible to use a conventional azimuth thruster mounted below the baseline when the vessel is manoeuvring alongside a quay or in harbours with limited water depth.

The Combithruster is based on the so-called ‘swing up’ thruster which has been part of the Ulstein propeller product range for many years and is now incorporated in Rolls-Royce’s marine equipment portfolio. The swing up thruster is hinged so that it can be rotated around a fixed point and parked in a horizontal position in the hull when it is not in use. When it is swung down out of the hull it can be operated as a normal azimuth thruster and a locking system ensures that the stem is fixed in the vertical position. Compared to a vertically retractable azimuth thruster, the swing up thruster requires significantly less vertical room in the hull.

The difference between the swing up and the Combithruster is only that when the latter is swung into the horizontal position it lies in a recess or cut out in the hull so that the azimuth function of the thruster can be used to give a pure athwartships force similar to a tunnel thruster. The diameter of the recess is somewhat larger than the outside diameter of the nozzle to permit a degree of circulation round the nozzle and in this way use the nozzle propellers well known characteristics to give a large thrust at low speed.

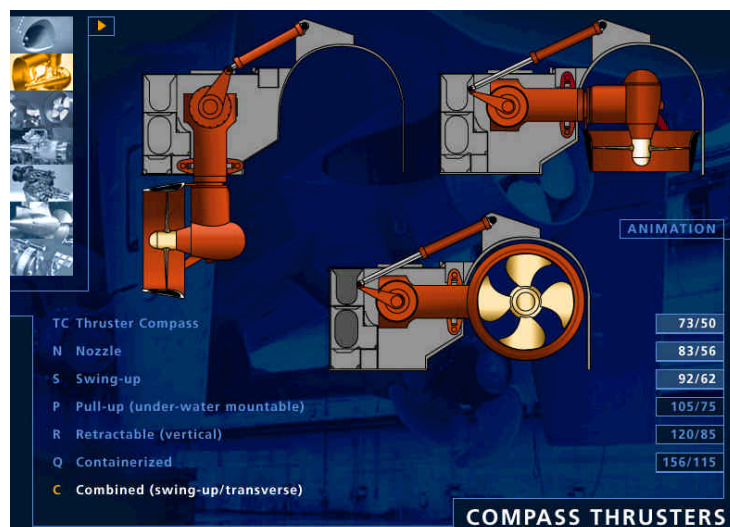
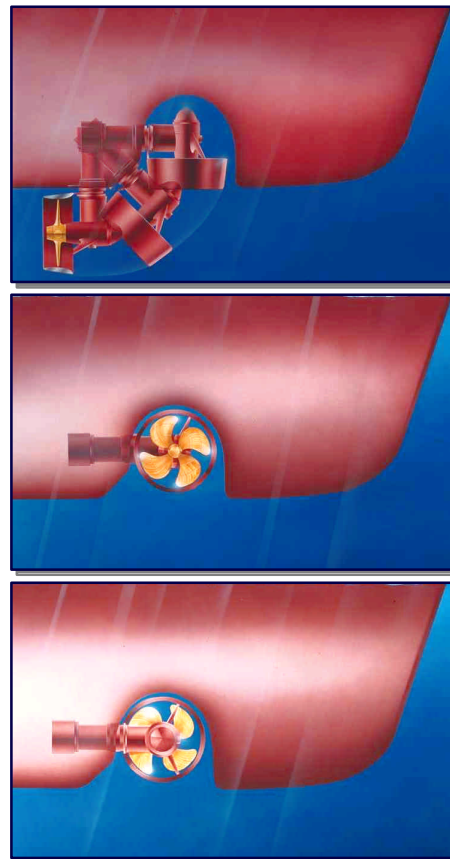

Fig. 5



**Azimuth-funksjon**

**Tunnel-thruster mode**

**Tunnel-thruster mode**  
**The unit rotates 180 degrees in recess and gives side force in opposite direction with the same turn direction on propeller**

Fig. 6

Figures 5 and 6 show how both the normal azimuth thruster function and the tunnel thruster mode are obtained in the Combithruster. What are the particular advantages of the Combithruster? To explain this it is necessary first to enumerate some of the tunnel thrusters inherent weaknesses. There are three principle weaknesses with tunnel thrusters which can be significantly improved with a Combithruster, these are:

1) High noise levels from tunnel thrusters because of a relatively large expanse of cavitation and intense cavitation. This causes problems since this type of noise is easily transmitted to the accommodation in the vessel and often exceeds either permitted or acceptable noise levels in cabins unless comprehensive and costly noise limitation measures are taken.

2) For a given power the tunnel thruster produces less thrust than azimuth thrusters (see Table 1).

3) Low initial immersion of tunnel thrusters can lead to sucking in of air in waves and a resultant loss of positioning force.

The demand for equal forces to starboard and to port require that the propeller blades of tunnel thrusters must have a symmetric cross section and the unhappy consequences of this were described at the beginning of the paper.

Figure 7a shows the cross section through a tunnel thruster blade on a CP propeller which can be pitched to port and starboard and shows the leading edge cavitation when the pitch exceeds a given angle. On the Combithruster cavitation can be minimised by optimising the skew and profile shape for a given direction of rotation and thereby use a foil shape with camber as in a wing profile and a radial pitch distribution which includes unloading of the blade tip.

When the Combithruster lies in its recess (i.e. tunnel thruster mode) there is an alternative way of obtaining opposite thrust which is by either altering the direction of rotation of the propeller or by selecting negative pitch in a CP propeller. This is a poor solution because the inflow is directed to the blade profile's trailing edge or, in the case of a CP propeller, the angle of attack and camber is wrong. This situation is shown in Figure 7b. It is, therefore, far preferable to use the azimuth function when the Combithruster is housed in its recess and to rotate the unit 180° to give thrust to port or starboard. In this way the propeller turns in its optimised direction, thus there is a significant reduction of cavitation induced noise and vibration. Figure 7c shows how this is done.

The Combithruster's capabilities in developing thrust in both the azimuth and tunnel modes have been researched in model tests at Marintek. A model of the hull of an anchor handling tug supply vessel of the type UT721 was modified and fitted with a recess to suit the Combithruster.

The drawing in Figure 8 shows the Combithruster in this hull both in the normal azimuth mode and swung up into the recess in tunnel thruster mode.

In the housed position the axis of the propeller shaft was adjusted relative to the horizontal by 2.5° and 5° while in the azimuth position, the degree of swing down was successively set at 83°, 85°, 87° and 90° to study how longitudinal forces on the vessel changed when the propeller wash streamed aft over the hull. Put another way, the inclination of the propeller axis with the base line was 7°, 5°, 3° and 0°.

CONVENTIONAL TUNNEL THRUSTER

STANDARD DUCTED OR OPEN PROPELLER

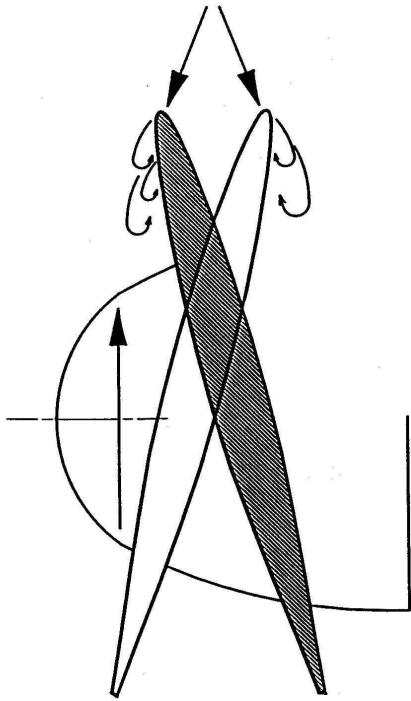

FIG. 7 A

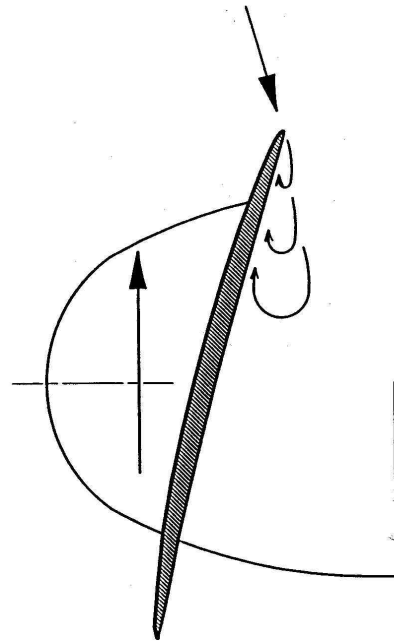

FIG 7 B

"COMBI THRUSTER"

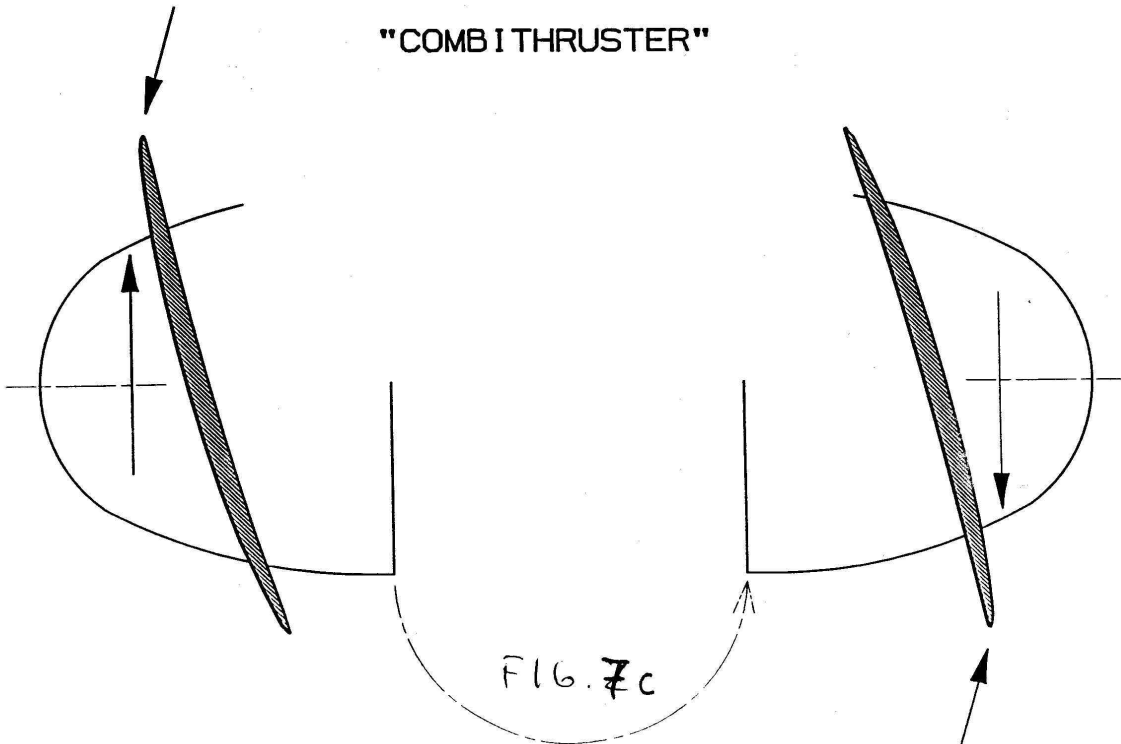

Figure 7 a-c

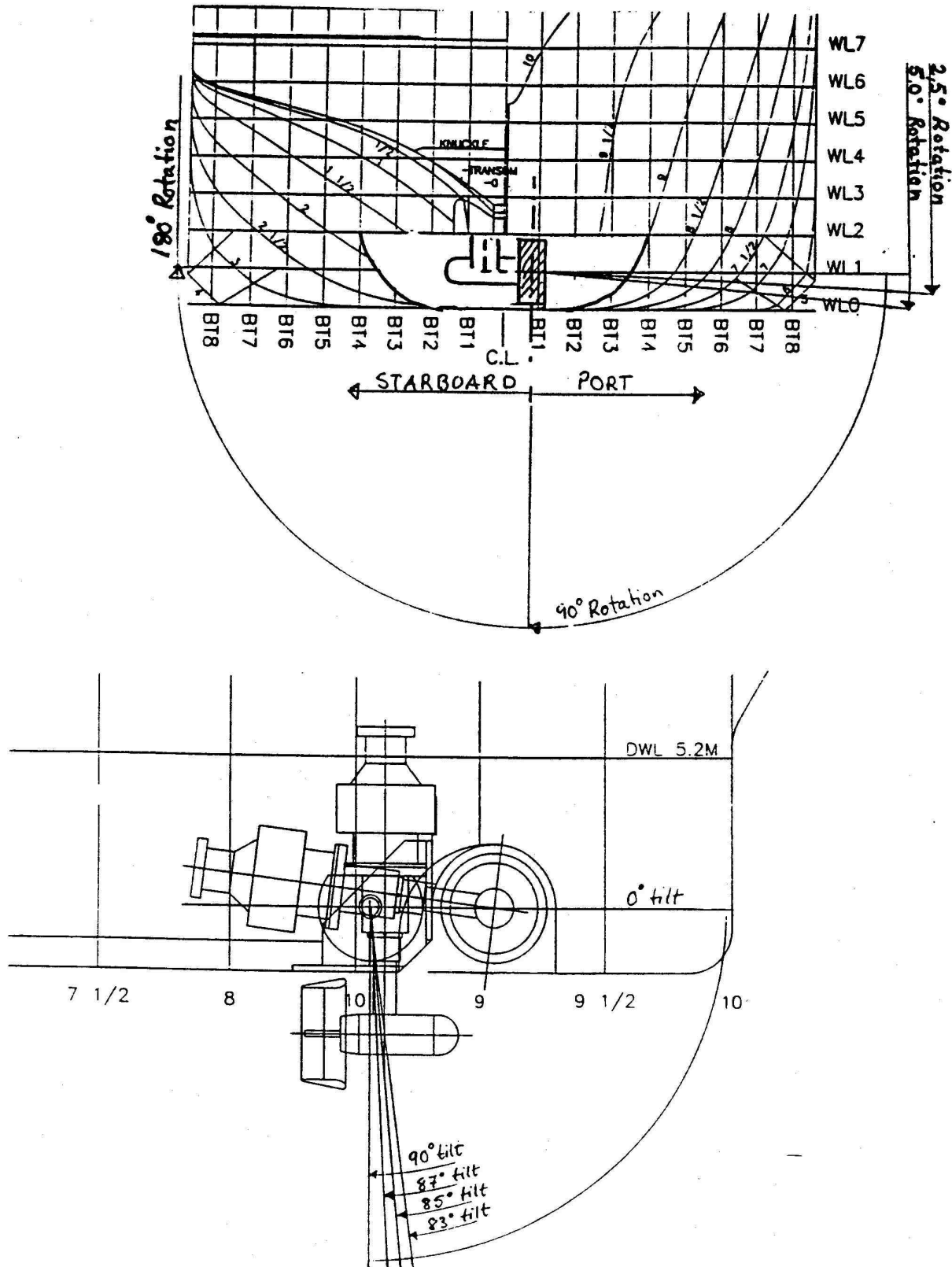

Figure 8

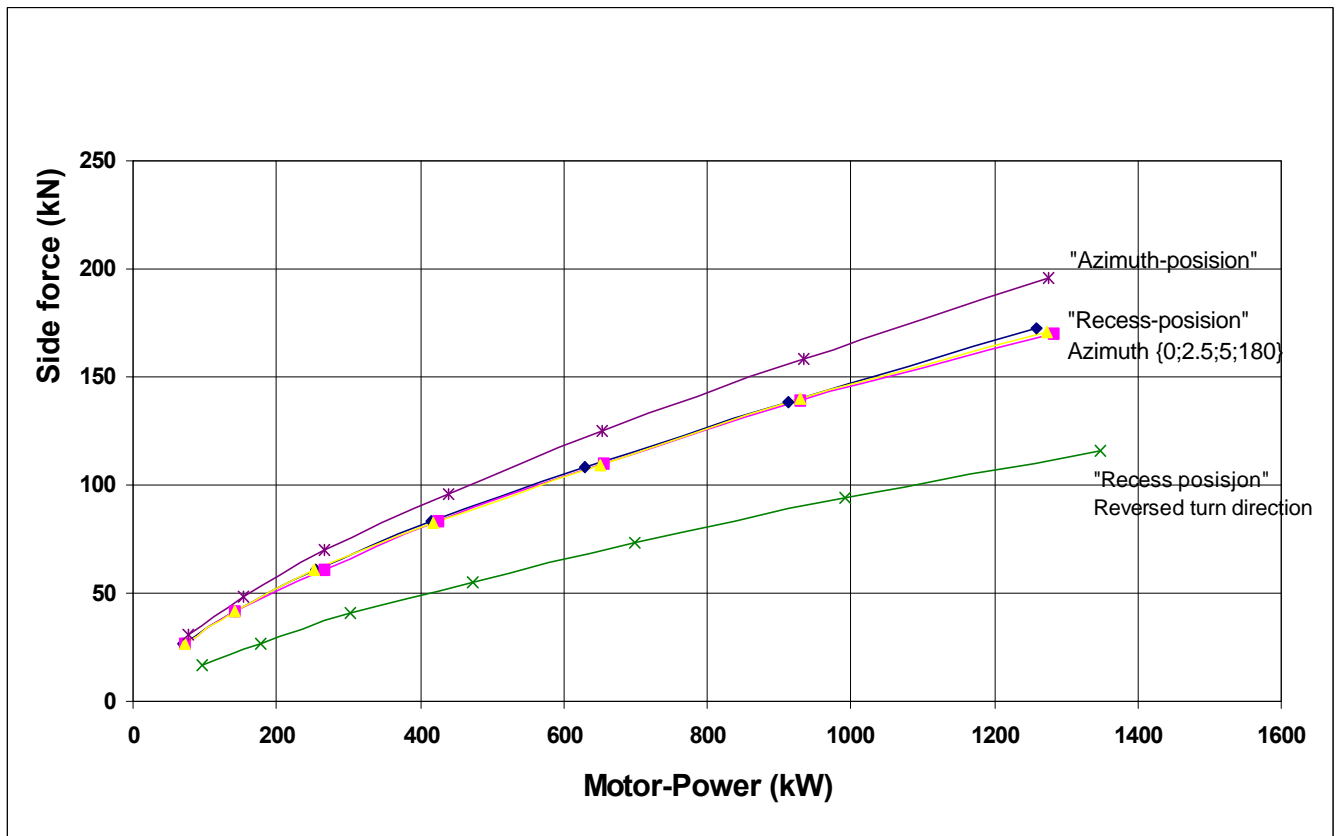

Fig.9

Figure 9 shows full scale athwartships force as a function of motor power for both the azimuth position and the various recessed positions. It can be seen that the side thrust is greater in the azimuth position than when the thruster lies in the recess. There are also marginal differences in force when the propeller and nozzle lie at 0°, 2.5° and 5° to the horizontal. In the same Figure, side thrust for negative rotation is shown and as explained earlier, indicates also in this test a marked reduction in thrust in relation to power for this mode. This confirms the importance of rotating the thruster 180° instead of reversing propeller rotation.

The Combithruster can be used in azimuth mode in DP to increase towing power, for example in a tug or anchor handler. Bollard pull is, of course, an important competitive factor for such vessels. In this case a modified locking system can be fitted so that the down swing of the thruster is less than 90°. The effect is that when the propeller axis points aft the angle to the horizontal causes the wash from the propeller to point below the horizontal. In this way the friction loss between propeller wash and the bottom of the hull is reduced and there is also less interaction loss with the main propellers.

Model tests have also shown here that this is desirable for increasing bollard pull, and on the latest offshore anchor handlers and multi purpose vessels with swing up or Combithrusters mounted at the bow, an 83° outswing has been used corresponding to 7° angle relative to the horizontal.

To summarise, the Combithruster's capabilities and advantages compared with conventional tunnel thrusters have been explained and it has also been demonstrated that azimuth thrusters have advantages relative to tunnel thrusters when it comes to positioning force in waves since they are less prone to loss of thrust caused by sucking in air and being lifted out of the water.

The significance of initial depth of immersion and loss of thrust under extreme conditions has also been the subject of studies, both theoretical and experimental (see references 10, 11 and 12). In reference 10 a theoretical method is used to estimate the loss of thrust on the main propeller and an azimuth thruster mounted below the bow of a 180m long production vessel. The result is verified experimentally in reference 12. Under extreme conditions corresponding to 12m significant wave height, there was a thrust loss of around 30% for the main propellers but only 5% for the azimuth thruster. This is explained by the greater immersion of the azimuth thruster relative to the main propellers. The relevance of differences in immersion to thrust loss in waves is clearly also relevant when evaluating a Combithruster relative to a tunnel thruster. Azimuth thrusters generally also have the advantage that the resultant thrust vector can be directed towards the resultant of external forces. Where water depth allows it the Combithruster should be used in its azimuth mode for most effective positioning and manoeuvring for the above reasons.

Thus far the paper has focused on the Combithruster's advantages and flexibility. There is a negative side and pains have been taken to reduce the added resistance created by the thruster recess. The model of the UT721 mentioned above was tested in the towing tank with a relatively simple recess shape made without special regard to reducing resistance. With a propeller power corresponding to 100% MCR on the engines, it was found that the additional resistance created a loss of speed of 0.25 knots compared to the original bow form of this vessel. It was clear that there are various ways of improving the shape of the recess to reduce the additional resistance. For this research it was desirable to use a high speed displacement vessel and Rolls-Royce were able to use a hull model of a cruise vessel which Kvaerner Masa Yards had tested at MARIN. The reason for choosing this hull form was that the cruise ship market is potentially an important market for the Combithruster, one reason being the comfort levels and corresponding low noise levels which are required in cabins on such vessels, some of the cabins being close to the thrusters. The reasoning was also that if it was possible to develop an attractive recess

geometry giving a low additional resistance for a vessel with a speed of over 20 knots, it would also be possible on slower offshore vessels.

Pressure distributions on alternative recess shapes were studied using the potential flow code RAPID using this cruise ship hull (see references 13 and 14). The towing resistance of four different hull configurations were subsequently measured. These four variations are shown in Figure 10 and were as follows:

- Configuration 1: Basic ship model without tunnel and Combithruster recess.
- Configuration 2: The ship model with two standard tunnel thruster openings with a small anti suction tunnel (AST) between them.
- Configuration 3: Ship model with the aft one of the two tunnel thruster openings plus the original recess shape for the Combithruster as used in the UT721 tests.
- Configuration 4: The ship model with the aft tunnel thruster opening plus a recess optimised using the RAPID analysis adjusted to the local hull geometry. Towing force converted to propulsion power for the various options are given as a function of ship speed in Figure 11. The power is given relative to the basic hull in Configuration 1. A fifth Configuration was also researched. This was identical to number 4, apart from removal of a protrusion on the hull just upstream of the recess.

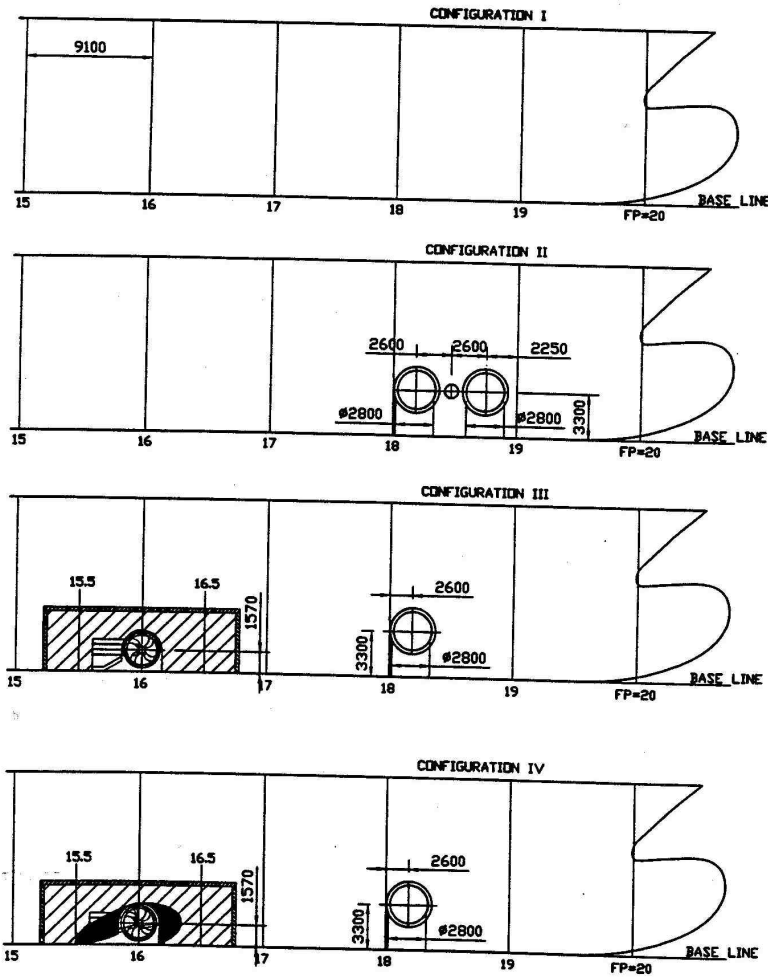

Figure 10

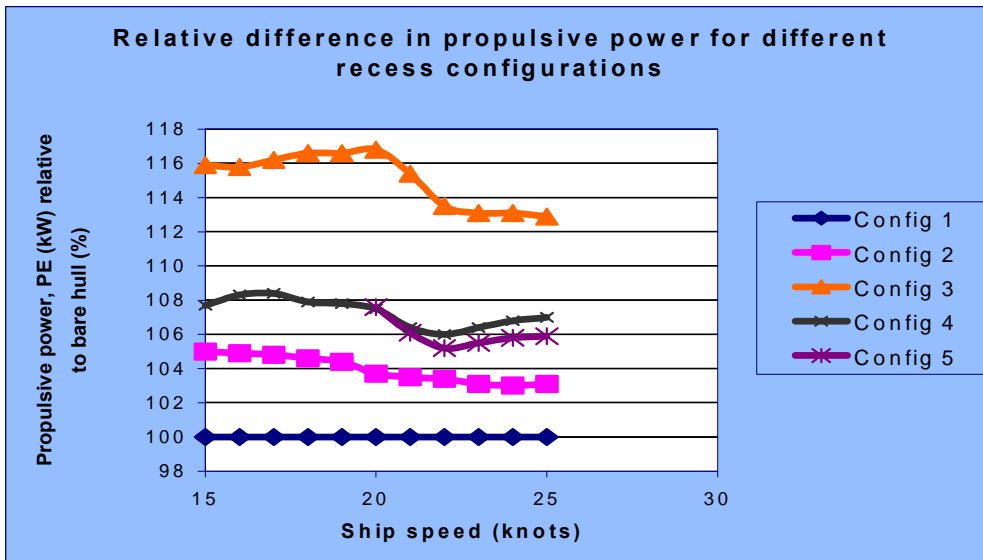

Fig. 11

Rune Garen, Rolls-Royce Marine AS      Thruster      A Thruster System which Improves Positioning Power by Reducing Interaction Losses

---

As may be seen from Figure 11 the original recess gives a significant increase in resistance relative to the basic hull. At 15 knots the increased power is 16%, reducing to 13% at 25 knots. Using the optimised recess geometry in Configurations 4 and 5, the power increase is reduced to 6% to 8% and lies a mere 1% to 2% over a standard tunnel thruster configuration.

## Conclusion

Results from model tests with hull and thrusters for the new fifth generation rig *West Venture* built at Hitachi Zosen have been summarised. The results of model tests show that thruster to thruster interaction losses and thruster to hull interaction losses can be sensitive both to azimuth angle and to the tilt angle of the nozzle. It is also shown that vertical tilting of the nozzle is an effective means of reducing thrust losses.

The Combithruster concept has been introduced and significant advantages have been documented for this type of thruster relative to conventional tunnel thrusters in terms of positioning ability. The Combithruster maintains at the same time one of the tunnel thrusters, namely that it can still be used when a normal azimuth thruster protruding below the hull could not be operated because of limited water depth.

Because the propeller of the Combithruster can be optimised for a particular direction of rotation and thrust, it is also possible to reduce cavitation noise and vibration transmitted to the vessel's accommodation.

## REFERENCES:

- [1] "Thruster-hull interaction effects", NSFI rapport R-119.81 , Erik Lehn
- [2] "Thruster interaction effects" , NSFI rapport R-102.80 , Erik Lehn
- [3] "Analysis of Thruster effectivity for Dynamic Positioning and Low speed Manoeuvring"  
U.Nienhuis , MARIN
- [4] "Deflection of propeller slipstream", Hans J. Thon , Marintek , May 1986  
Rapport fra Forskningsprogrammet : Marine Operasjoner Del II-"Thruster Characteristics"
- [5] "On the propeller race interaction effects" , Erik Lehn  
Marintek publikasjon no. P-01.85, September 85
- [6] "Thruster interaction on the Yatzy platform", Erik Lehn  
Liaaen Helix A/S, September 1985 , konfidensiell rapport.
- [7] "Thruster interaction tests with a semi-submersible drilling unit, " Erik Lehn  
Liaaen Helix A/S, Februar 1986 , konfidensiell rapport.
- [8] "Wake adapted ducted propellers", Dr.Ir. M.W.C Oosterveld  
Publication no. 345 , Netherlands Ship Model Basin , NSMB – Wageningen
- [9] "Development and merits of a combined tunnel and azimuth thruster (Combi-thruster)  
Rune Garen and Jahn Terje Johannessen – Ulstein Propeller AS  
ImarE Conference Proceedings pp.19–39 ,  
The 21<sup>st</sup> Century Cruise Ship Conference , London 15-16 April 1999
- [10] "Practical Methods for Estimation of Thrust Losses" , E Lehn  
FPS-2000 Mooring and Positioning, Part 1.6 Dynamic Positioning – Thruster Efficiency
- [11] "Estimation of Required Thruster Capacity for Operation of Offshore Vessels under  
Severe Weather Conditions ".  
K J Minsaas, H J Thon, W Kauczynski , S I Karlsen – Marintek  
PRADS' 87, The third International Symposium on "Practical Design of Ships and Mobile Units
- [12] "Thrusters in extreme conditions" . FPS-2000, Part 1,2 and 3.  
E Lehn og K Larsen, Marintek 1989.
- [13] "Nonlinear ship wave calculations using RAPID method" , H C Raven, MARIN  
6<sup>th</sup> International Conference on Numerical Ship Hydrodynamics, Iowa City, 1993.
- [14] "Application of nonlinear ship wave calculations in design", H C Raven and H H Valkhof  
MARIN, 6<sup>th</sup> PRADS Symposium, Seoul 1995.