



DYNAMIC POSITIONING CONFERENCE
October 17 – 18, 2000

RELIABILITY

Degraded Status

Chris Jenman
Global Maritime (London)

DEGRADED STATUS

ABSTRACT

All DP vessels are degraded to some extent all the time because of planned maintenance, testing, breakdown or repair. This can mean that they are not strictly in DP class 3. This may not mean that it is unsafe to continue working but it creates a new ‘intact’ situation that has to be managed. The effect of degradation commercially and in terms of risk are matters that depend on

- *the view of the client and the contract*
- *the level of initial redundancy*
- *the weather conditions*
- *the work being done*
- *the water depth*
- *the acceptable risk*

This paper provides some typical degraded situations and asks what is acceptable and how should a consistent evaluation process be achieved.

INTRODUCTION

DP class 3 is, as the IMO MSC645 (ref. 1) states an equipment classification; it specifies the amount of equipment redundancy is needed for achieving DP class 2 and 3. The DP rules from the classification societies line up reasonably with IMO. For some class rules an environmental condition has to be specified for the DP class on the basis that while station keeping is possible in higher sea states and currents a worst case failure situation would be followed by a loss of position (drift off).

Class rules do not deal with operations nor do they attempt to include the work of the vessel although in practice this might be taken into account. For example the thrust needed for pipe tension, the power needed for lifting heavy loads, running the riser, the current loads on these items etc are generally not accounted for but left to the owner. This is quite reasonable because throughout the life of a vessel it is quite likely that her work profile will change.

Class rules do not deal with degraded status but assume all the class 3 equipment is available (unless informed otherwise by the owner). Again this is reasonable because there are too many variables and any consideration in this area will only appear as negative marketing to the owner. Class does of course cover DP capability in the intact condition and after the worst case failure in that this has to be a known quantity, (many DP control systems now have the option for on line capability plots).

The third area that class does not address is the capability and competence of operators. Again this is reasonable as this area is covered to some extent elsewhere IMO MSC738 (ref. 2) and on each vessel manning is an ever changing situation. Nevertheless a change in operators can degrade the status of a DP vessel operationally or significantly improve it even to the extent of mitigating equipment shortfall.

So the situation with respect to DP rules is fairly stable and reasonably understood. The subjects that need careful attention are the areas of

- operations
- equipment unavailability
- key DP personnel

OPERATIONS

The only reference that covers operations is IMCAs M103 (ref 4) entitled “Design and Operation of DP Vessels”. In the first section, that deals with the principles for all DP vessels, the concept of the time to

reach a safe situation is put forward and applied to all DP vessels. This means that there is great flexibility for owners of DP vessels and their clients to keep working, provided at all times in the situation of the worst case failure, there is adequate time available to reach a safe situation.

This means:

- (1) for DP DSVs, that the divers and the bell are in positions such that no matter what happens (worst case failure or less) they can be safely recovered (no second independent failure during the process):
- (2) for DP HLVs the lift can be cleared or landed
- (3) for DPAVs gangway connected, the gangway can be lifted and the vessel move to avoid collision
- (4) for DP MODUs a successful disconnection is possible.

The equipment installed on board, the equipment available and the equipment on line has an impact on the above operational situations but so does:

- the opinion of the client rep
- the weather conditions
- the work being done
- the water depth
- the competence of the key DP personnel

NORMAL CONDITION (GREEN)

In order to have a definition of degraded status one must first consider the normal operational condition. This would, at first glance, seem simple but there is an increasing difference of opinion brought about by the many different designs and systems in operation, the advance in thruster drives and the speed of system response. In the mid 1980's when the present DP rules were being developed the most advanced designs had twice the equipment that was needed to keep position and the worst case failure could cause the loss of half. So the normal case was all the thrusters running at less than 50% load and enough generators running at less than 50% load and as many position references as reasonably possible on line. The main operational problems with this arrangement were

- generators at low loads
- poor power factor
- thrusters burning power at zero thrust

These problems still exist because these vessels are still in service and the temptation is to put fewer generators on line to get 70-80% load and to stop one or two thrusters. This can expose the vessel to the risk of drift off from inadequate power and thrust (until more equipment is on line) or total blackout and drift off. Such set up conditions are against DP class 2 and DP class 3 design and rule intentions. Nevertheless it could be argued that with

- Excellent operators
- Great PMS response
- Adequate excursion tolerance

this “normal” or good weather set up is safe in that it has acceptable risk.

In recent discussions of the IMCA Marine Division Management Committee we have considered providing a guideline to enable each DP vessel to document her normal operational condition and justify this so that this grey area is no longer grey but vessel specific. The other reason that this vessel specific document is important is because it avoids a misunderstanding. Increasingly in DP documentation the concept of a vessel sometimes being in DP class 2 and something being in class 3 is being used. The suggestion this makes is that a vessel can operate in a safe and a less safe condition depending on the situation. This would be difficult to defend in court during any litigation after a DP incident or accident.

So the normal DP 3 vessel operational condition should be the safest system set up possible. If the owner wishes to come to a safe system below the safest condition for commercial reasons i.e. save fuel, increase uptime, make time available for maintenance etc then he has to show that this is reasonable. He could do this by showing the risk difference is negligible/acceptable. To be confident that such a decision is “reasonable” and not “negligent” it has to be defensible in any investigation after an accident or incident. This means, ultimately, that the person responsible or the company cannot be prosecuted for manslaughter.

Until recently the safest and normal operating condition of a vessel was with active redundancy because there is a definite difference between system reliability with active redundancy than there is with passive redundancy.

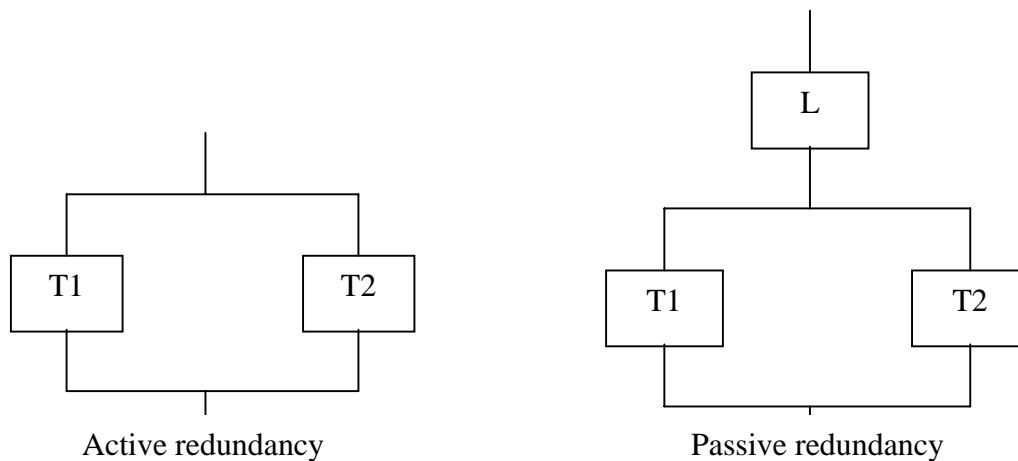

The reason for this is that with passive redundancy one has to rely on additional equipment which can be modelled as all the components that detect the failure and start the passive redundant unit and bring it on line. The best illustration to mariners is to ask them how confident they are of the emergency generator starting in the case of a blackout and then ask them to explain their answer. The answer will list all the silly things that cause the emergency generator to fail. They will usually add that the probability of failure during a weekly test is smaller than the probability of failure during an actual blackout and then they will blame “Murphy”!

The underlying cause of this difference is that on the day when the emergency generator is to be tested the chief engineer will have had the system checked out and if the engineer or the electrician doing the job is competent the chance of failure is reduced. (If it is the first time he had done it or he is not competent or too inquisitive the chance of failure might be increased of course). This principle should be part of any analysis if passive redundancy is being considered for major items of equipment like thrusters and generators.

With the latest DP vessels it is possible to prove on trials that being reduced to just one generator on one switchboard and little or no thrust from any of the thrusters it is possible to recover before much position loss has occurred. It is also possible to demonstrate that even after a total blackout all necessary

generators and thrusters can be on line in less than 2 minutes and that the loss of position is insignificant. However, if one examines the number of items in the recovery chain that need to function 100% and then subject them to OREDA (ref. 5) type reliability data little confidence can be gained that everything will work when the system is called on once every two years (say) to save the day. The other problem with these systems is that the operators have to do nothing until they are certain the automatic system has failed. This is very difficult for “hands on” experienced key DP personnel.

So to conclude a definition for the normal operating condition is difficult but the following is suggested.

The normal operating condition for a DP vessel is the set up of systems and equipment whereby any design failure mode relevant to her DP equipment class or any other reasonable failure mode found by past operational experience will not cause an unacceptable loss of position or excursion in the existing circumstances and environmental conditions or lead to a situation that could be expected to cause confusion such that a reasonably competent operator could make an error and hence an unacceptable loss of position.

The above is independent of DP class and has little to do with the DP classification given by the vessel’s classification society, it has everything to do with uptime, safety efficiency and profit. Should something go wrong then the words that will be discussed at length are “reasonable”, “unacceptable” and “reasonably competent”. The advantage of using these words is that they give flexibility and their interpretation can change with time.

This definition is also important when a client has hired a DP class 3 vessel and understands by this that the equipment required to obtain class 3 has to be available to him and if it is not the vessel is in degraded status. Of course if a vessel has equipment on board that is not available then it is degraded. The important question is does this matter.

DEGRADED CONDITION

A degraded operating condition for a DP vessel is a set up of systems and equipment whereby any design failure modes relevant to her DP equipment class or any other reasonable failure mode found by past operational experience is likely to cause an unacceptable loss of position in the existing or reasonably anticipated circumstances and environmental conditions or lead to a situation that could be expected to cause confusion such that a reasonably competent operator could make an error and hence an unacceptable loss of position.

The above is almost the converse of the normal condition but a margin is placed in the position loss by using “is likely”. There are two other points that this suggested definition intentionally makes. The first is in the “or any other reasonable failure mode found by past operational experience”. This implies that the experience comes from

- the vessel in question
- the DP industry in general
- the operator himself

The second is the “reasonably incompetent operator”. This is used because every vessel owner or manager (as appropriate) would never agree that his operators were anything less than “reasonably competent”. However these words would also mean “the least competent operator in charge of a watch”. It would be no defence to Master or Chief Engineer were assumed to be on watch when deciding the normal and degraded status system and equipment set up.

For a class 3 vessel to be working in class 3 in modern parlance one would expect three DP control systems to be active with three position reference inputs, three gyro compass inputs, three wind sensors etc etc. One would expect all the inputs and processors to be working properly at the start of any contract and the client is likely to verify this situation. The client would expect all the DP control system equipment to be available continuously except for minor problems that are fixed on board relatively quickly. The response to these failures would depend on the work in hand generally and the task at the moment of failure. For diving work where it is a relatively fast procedure to bring the divers back to the bell and recover them to the surface a strict policy is possible and correct. There is good risk (benefit) reduction available at the cost of little disruption. For a heavy lift stabbed and partly transferred the continue option is safer than the reverse. For a DP drilling unit there are three options

- wait and see
- controlled disconnection
- emergency disconnection

Clearly the wait and see policy is attractive and the most sensible if the problem can be quickly fixed, the fixing operation will not risk further degradation and the emergency disconnection operation is available. However while working in deepwater gives a good time margin for a successful emergency disconnection these deepwater locations are remote and some failures may take weeks or months to remedy. This may leave a DP 3 drilling unit out of class for a long time and according to the client contractually in degraded status.

In studies we have carried out for several new build vessels in order to quantify the DP class 3 availability, we have found that even with good quality DP control system equipment the number of hours when a unit is not strictly DP 3 is large. The reason is simple all the equipment is in series and nothing is perfect.

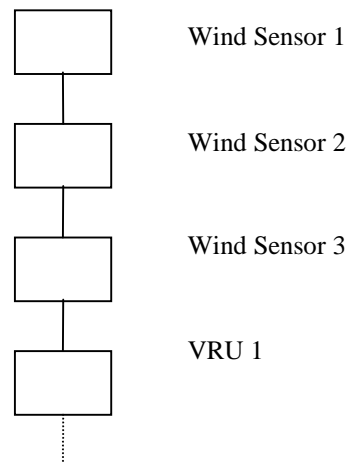

If we consider wind sensors then it could be argued that in some conditions the fact that no wind sensors are available would not be a problem. For example in deep water where a position excursion of 50m would not cause an operational problem no wind sensors could be acceptable i.e. not even a yellow alert but a green (advisory) status only. The problem is that the whole assessment of the vessel has been based on three and there is, without a doubt, an increase in risk of a loss of position if no wind sensors are available. This risk increase is because

- a failure can occur when the vessel is further off position than normal because there are no wind sensors
- the operator is making decisions based on experience with wind sensors and may reject other unusual responses because of this when it is in fact a new problem
- failure of all three wind sensors may have a cause that has degraded equipment elsewhere that is at present hidden

It is not suggested that these items are very serious this is used as a simple example which when applied to other equipment could be very important. For example if one sensor, that detects zero volts on a switchboard and is part of the automatic blackout recovery system, fails such that the automatic recovery will not work or not work completely there is a degraded status that may alter the accepted normal operating condition discussed earlier. It is doubtful if this item would be considered unless its function was fully appreciated.

For many vessels the DP operations manual gives some guidance to operators on what failures constitute a yellow and red alert. For the drilling industry using DP vessels an advisory category of alert has been introduced that is sometimes called green (advisory) or blue. It covers the situation where a failure has occurred but in the view of the DPO, backed up by the well specific or general guidance on board, operations can continue. The problems with even well specific guidelines is that there are still several variables and hence the risk of error. Scenarios where errors can be critical are:

- several minor faults exist and the overall effect of the combination is unknown/uncertain
- the well specific limits do not taken into account high currents and/or sudden wind changes
- the limits are too harsh and hence ignored or given an extra unofficial margin
- the contract has penalties for degraded status

SAFETY MANAGEMENT

The management of safety irrespective of the system used always includes the management of non-conformances. A degradation of the DP system so that it no longer has all the equipment required for her DP class 2 or 3 is a non-conformance and should be dealt with according to the SMS in place. This would normally mean that the key DP personnel would discuss the situation and in fact carry out a risk assessment and see if the situation has any mitigating factors that can be applied. A good example to illustrate is the failure of a thruster such that it cannot be used. Some illustrations are proved below.

Case 1 ONE THRUSTER FAILURE

Semi submersible

8 azimuth thrusters in total (2 in each corner)

3 thrusters enough to DP most of the time

Result Green status
 Re arrange thrusters if only 6 on line
 No change in limits

Case2 ONE THRUSTER FAILURE

Drillship

6 azimuth thrusters (forward bow thruster most useful)

3 with bow thruster enough to DP

2+2 without bow thruster enough to DP

Result Green status if not bow thruster
 Green (advisory) if bow thruster fails may lead to yellow

Case 3 **ONE THRUSTER FAILURE**

Semi submersible

6 azimuth thrusters, 2 switchboards

3 azimuth thrusters enough to DP (2 azimuth thrusters with alternative supplies)

Result Green (advisory)

Revision in limits because worst case failure can result in only 2 azimuth thrusters until one has supply changed over.

In this case there would be discussion on the time for change over and its reliability. It is likely that there would be strong pressure if this was a drilling unit for the limits not to be changed. For an MSV supporting divers there would be a yellow alert and discussions as to whether the work should continue.

Case 4 **ONE THRUSTER FAILURE**

Drillship

5 azimuth thrusters

1 bow tunnel thruster

4 thrusters needed to DP (bow thruster and one forward plus any two azimuths aft)

Note: Single fault can fail bow thruster and one forward until change over (change over manual).

Result (bow thruster failure) Red alert until changeover

The above is illustrative because it shows a situation where a single failure can cause a red alert (loss of heading) until a changer over is made and it should not be possible to go straight to red alert for a single failure.

Case 5 **ONE THRUSTER FAILURE**

Semi submersible

4 azimuth thrusters (one each corner)

2 thrusters adequate for most conditions (each thruster with alternative supply)

Result Green (advisory) (if 4 on line initially)

Yellow alert (if 3 on line initially)

Red alert (if 2 on line initially)

The above case is one of the most interesting because the starting and change over of thrusters supplies is fast and automatic but of course if reduced to one thruster the vessel is no longer able to DP and this is certainly not class 3 or class 2 DP philosophy.

The above cases are simple but can even so cause much discussion on board between powerful individuals and result in the strongest personality determining the result. If there is any doubt in the mind of the shore based “responsible person” that the best solution will prevail offshore then the guidance provided on board for such situations must be stronger. If unsuitable decisions are made and an incident or accident occurs it is better if the guidance was clear.

The management of a DP vessel’s degraded status is not a new topic but it has been given more importance in the author’s opinion because

- modern systems are more complicated
- deepwater provides more time to mitigate and recover from problems
- operators need to know more about a complicated vessel to make proper judgements
- experience on less complicated vessels may not always be relevant

- drilling units in particular have less active (moving, set up manoeuvring) DP operational time for operators to gain “quality” experience

CONCLUDING REMARKS

DP vessels will frequently be operating with some equipment, that is essential for DP class 2 or 3, unavailable. This can however mean that it is safe to continue working. Thus it is important to make sure each DP vessel has good vessel specific guidelines to manage a degraded situation and that the key DP personnel have enough understanding of the complete design to determine the status correctly. This understanding must enable logical discussion particularly when several relatively minor items are unavailable because their sum could be very significant.

For some vessels the suggested definition for a degraded status will be a problem because they do not execute annual trials, which gives key DP personnel an opportunity to see complicated control systems recover from major failure modes.