



DYNAMIC POSITIONING CONFERENCE
October 17 – 18, 2000

POWER PLANT

Drilling Vessel Power Plant Control Systems

Jon Boaz
Automation Solutions, Inc. – Houston, TX

Introduction

Power plant control on marine drilling vessels must be responsive and robust as mission critical power demands are very dynamic. Drilling system loads for example can change from no load to several megawatts in milliseconds. Additionally, through out these swings, power for other shipboard equipment such as bilge pumps, ballast pumps, propulsion and thrusters must be available.



A novel power management and blackout protection system was designed for the Vessel Management System, VMS, installed during the Glomar Explorer refit for deepwater drilling service. In addition, Automation Solutions Inc. was chosen by Global Marine Drilling Company as the System Integrator to develop the VMS. Through an Open System approach Automation Solutions, Inc. was able to meet the design specification while also providing improved performance, ease of use, and lower cost than traditional industrial control systems. Several years of deepwater drilling operations worldwide have proven the VMS system to be reliable and powerful.

The philosophies and decisions that influenced the design of the Glomar Explorer VMS will be discussed. The following areas in particular will be highlighted.

- What the Open System Approach Is
- The Glomar Explorer VMS Architecture
- Power Plant Control Philosophies

Finally, the performance of the Glomar Explorer VMS will be reviewed.

Glomar Explorer

In 1996 Global Marine Drilling Company began the refit of the Glomar Explorer for deepwater drilling service. The projected vessel classifications were ACC and DP-2. As part of that refit Automation Solutions, Inc. and Global Marine Drilling Company designed a VMS that would seamlessly provide control and monitoring for existing and new equipment. The placement of the new equipment and severe space constraints dictated a highly distributed system. There are paybacks in reduced instrument wiring costs due to this strategy, however, a much greater emphasis is placed on reliable communications between system components.

The situation is further complicated as similar constraints were experienced in regard to instrumentation and instrument wiring associated with the new DPS, Dynamic Positioning System. As a result, the Nautronix ASK DPS was required to route DP (dynamic positioning) commands through the VMS to control elements. This requirement further emphasized the necessity of a robust and high-speed communication network between VMS and DPS components. It was decided that an Open System, which is capable of integrating these various subsystems, and which could meet the dynamic control requirements of a marine drilling rig, would be the most successful approach to developing a VMS.



VMS Engine Control Room
Console: Startup

The most important mission of the VMS however, is to provide reliable power for DP and drilling. The power management and blackout protection systems must extend to new as well as existing power generation and distribution equipment. Five Nordberg driven, 3.5-megawatt generators, originally provided power for the Glomar Explorer. An A and B bus distributed power to nine Siemens SCRs. These SCRs drive Main Propulsion, three bow tunnel thrusters and two stern tunnel thrusters. To this existing generation capacity, Global Marine Drilling Company added four EMD driven 2.2-megawatt generators located in a new engine room. This power is distributed through new C and D buses to Siemens SCRs driving four new Lipstronic 3000 horsepower azimuthing thrusters.

Open Control Systems

The emergence of standards in computing and networking such as Microsoft Windows, client-server interfaces, Ethernet, and TCP/IP have brought about fundamental changes in the automation industry. The general computing and networking markets are much larger than the industrial automation market and as a result have larger product research and development budgets. This has allowed products leveraging these technologies to improve more rapidly to provide new functionality and greater reliability at lower costs. It has become a necessity for automation product manufactures to incorporate these standards into their products in order to remain competitive in cost and functionality.

An Open Control System however, is one that leverages these standards in computing, networking and control to the fullest extent possible. Because of the adherence to standards Open Control Systems offer significant and cost saving advantages over systems that continue to have proprietary components, interfaces and communication methods and protocols.

-
- The best mix of hardware and software can be selected for a control system based on price, performance and extensibility.
 - The extensibility of Open Systems allows the addition of specialty hardware and software to address requirements specific to an application.
 - Open System extensibility also allows the incremental addition of components to meet future requirements.
 - Customers who have installed Open Systems are not bound to one vendor as competitive products from different vendors that adhere to standards can be selectively substituted for existing components.
 - Employees and contractors that are knowledgeable and qualified to work on the system or its components are widely available.
 - The careful selection of components utilized in the Open System can insure the availability of spare parts worldwide.

For the sake of discussion the components of an Open Control System can fit into three functional layers, the Supervisory Control Layer, the Network Layer and the Controller Layer.

Supervisory Layer

The most common Supervisory Layer components are user interfaces through which activities in the Network Layer, the Control Layer and connected equipment and processes can be viewed and maintained within operating tolerances. These user interfaces are referred to as HMIs, Human Machine Interfaces. Additionally, this level can include computer controls that address the automation problem more globally than the Controller Layer. These systems may include data collection and management applications; compute intensive control software, or plant or equipment optimization software running on dedicated computers.

Most HMI products marketed today are software that leverage Microsoft Windows operating systems and run on standard Intel computers. These HMIs have displaced proprietary products due to the power of Windows NT and common computing hardware. Automation systems based on currently available HMIs can address the largest control applications. For example, a large VMS for a drilling vessel can have as many as 5,000 I/O data points in its database. Leading HMIs running on powerful desktop computers can handle more than 10 times this many points. Usually the limits are artificial software limits established to give a guaranteed performance envelope.

HMIs have evolved rapidly in a highly competitive market to provide a wide range of automation capabilities that can be selectively implemented or customized for different applications.

- Dynamic and real-time views of activities, conditions and status in the Network Layer, the Controller Layer, processes and equipment can be portrayed in animated computer graphics.
- Control parameters and alarm thresholds can be adjusted through the computer graphic screens.
- Alarm circumstances associated with system components or with process or equipment conditions can be detected, indicated in the computer graphics and audibly annunciated.
- Actions taken by users to address alarm situations or routinely adjust control parameters can be tracked through computer logs.
- Process and equipment operating data can be archived to computer logs for future reference and offline analysis.
- User prompts to insure appropriate response to critical operations or alarms can be designed into the animated computer graphics.

- The system can be designed to notify management and supervisory personnel of special operational circumstances.

Network Layer

The communication connection between the Supervisory Layer and Controller Layer components is the Network Layer. The network hardware and software is the bond that brings all of the subsystems together and as a result the network speed, reliability and openness are critical to the success of the automation system. There have been endless debates regarding different network technologies however, in the general computing and network market, TCP/IP Ethernet is the clear winner. There is not a more open standard for automation.

There are also debates regarding the reliability with which different communication standards deliver data, deterministic methods versus non-deterministic methods. In either case the speed and reliability with which data is delivered is a function of the network bandwidth and actual network loading. Bandwidth is a measure of the volume of traffic a system can accommodate. Network loading in Open Control Systems is usually within the control of the system developer. Planning and judicious use of network resources can insure satisfactory system performance. In summary lightly loaded networks with high bandwidths will deliver data with the highest reliability and speed.

Controller Layer

Process and equipment control is performed primarily in the Control Layer. The control is accomplished in a cycle or closed loop in which the industrial controller measures or detects changes in process or equipment conditions and then initiates control adjustments to keep those conditions within operating tolerances. For power management in a drilling vessel this control cycle should be performed on the order of 100 milliseconds. This “Scan Rate” is relatively high for configurable controllers and generally dictates the use of PLCs, Programmable Logic Controllers.

PLCs are the most widely used controllers in the automation market. They were originally designed to replace hard-wired relay logic in manufacturing applications. PLCs however, have developed strong communication capabilities and have essentially set the form factor and packaging standards for the modularly expandable I/O in all industrial controllers. In addition, PLCs were among the first industrial controller to support open standards such as Ethernet TCP/IP.

The most important characteristics with regard to the controllers used in critical marine drilling applications however, are reliability, robust I/O and redundancy. The primary statistical measurement of the product reliability is Mean Time Between Failure, MTBF. PLCs have the highest MTBF some of which exceed 400,000 hours. This reliability extends to the I/O as well as the CPU. Additionally, isolated I/O modules with strong transient protection are commonly available from the PLC manufacturers. Finally, the leading PLC manufactures support redundant configurations that provide for transfer of control and I/O from a failed controller to a backup within a minimum CPU cycles. In addition there are circumstances in which a control modification or upgrade must be performed while drilling. With redundant controllers the change can be made without interruption of service, to the backup unit followed by a forced failover. In the most critical shipboard applications redundant controllers can insure against loss of control and can provide a valuable maintenance tool.

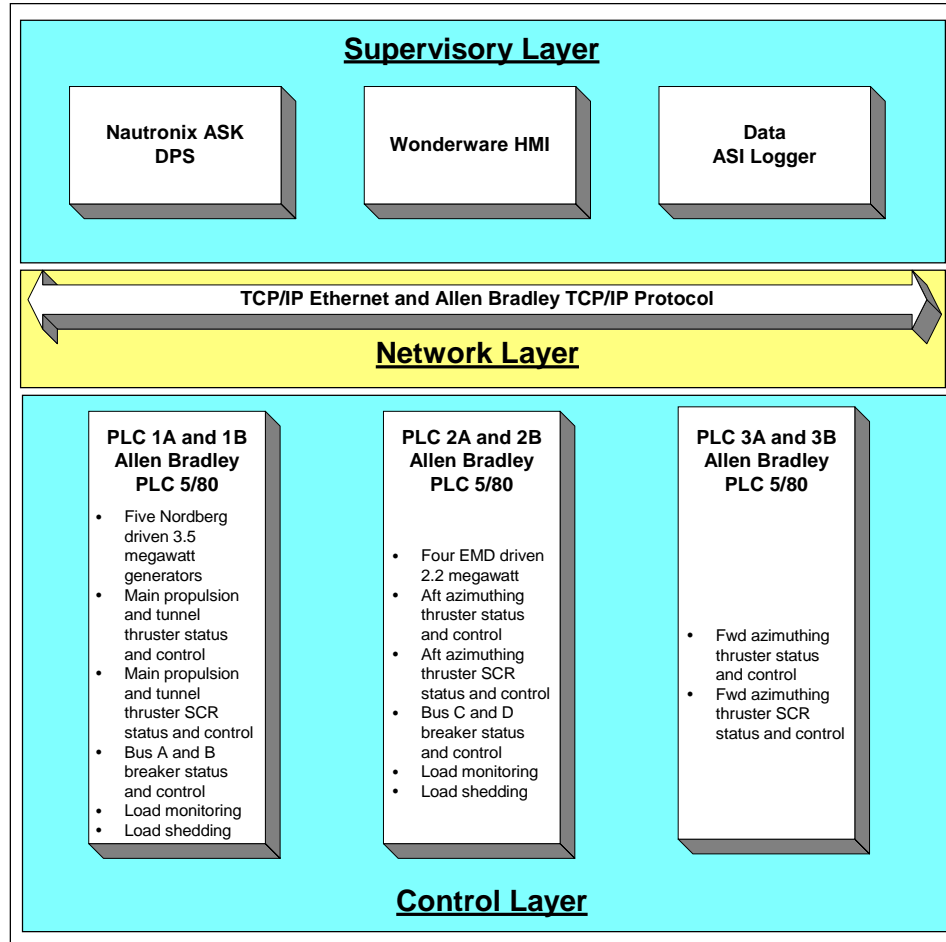

Glomar Explorer VMS Architecture

Supervisory Layer

The Supervisory Layer of the Glomar Explorer VMS includes seven HMI computers, three Nautronix ASK DPS Consoles and a Data Logger computer. These components are distributed through the vessel and connected to the VMS controllers via the Network Layer.

- Four HMIs are located in the Engine Control Room
- One HMI is located in the Afterward SCR Room
- One HMI is located in the Forward SCR Room
- One HMI is located in the Afterward Pilot House
- The ASI Data Logger is located in the Engine Control Room
- Two Nautronix Consoles are located in the Afterward Pilot House
- One Nautronix Console is located in the Forward Pilot House

DP commands and feedback from the Nautronix consoles to main propulsion and thrusters SCRs, and the thruster control package is conveyed through the VMS Network and Control Layers. Additionally in order to support positioning from any DP console at any time the DPS consoles must also be synchronized with each other over the VMS Network Layer. Due to the mission critical nature of dynamic positioning, DPS communications is given the highest priority and network loading due to the VMS HMIs and data logger was a design concern. The time specification for reception of feedback on DPS commands was 500 ms.

The seven HMI systems for the Glomar Explorer were based on Wonderware Intouch Software, Microsoft Windows NT and Intel computer hardware. The hardware used was a mix of industrial hardware that meets ABS standards and lower cost desktop hardware. The Wonderware Intouch software was configured to provide animated screens providing operation details a diagnostics associated with VMS components, generators and engines, main propulsion and thruster SCRs, MCCs, tie and breaker status' associated with power distribution, power loads associated with buses and subsystems, azimuthing thruster controls, bilge and ballast systems, ventilation fans and blowers, and other equipment. The screens developed for the Intouch system are responsive to the system conditions and operator input. For example, when power management logic recommends starting a generator, pop-up windows appear with the recommendation and appropriate controls for the highest priority generator. If the engineer decides to start the engine, he selects the control with the touch screen monitor and interactive screens take him through a normal start sequence.

Finally, the ASI Data Logger, which was provided by Automation Solutions, Inc., runs on Microsoft Windows NT and an industrial workstation. The logger collects approximately 1,500 data points every second from the Nautronix ASK DPS and the VMS. The logger archives data by component either on interval or change of state (deadband) into Microsoft Access files, which are copied to removable disks for analysis by shore-based maintenance personnel.

Network Layer

The Glomar Explorer control network is based on a redundant 10-megabaud Ethernet TCP/IP LAN and Allen Bradley's TCP/IP protocol. All Supervisory Layer and Control Layer products communicate via the Allen Bradley TCP/IP protocol. The LAN is based on a redundant, fiber optic network that forms a loop extending on both sides of the vessel. The fiber media converters provide the redundancy that can compensate for the failure of two fiber optic segments. In addition, the fiber optic converters have diagnostic I/O that is interfaced to the VMS controllers to allow detection of fiberoptic network degradation before complete failures occur. The diagnostic I/O proved to be especially valuable during

system startup as the network could be eliminated as a possible source of trouble during I/O to HMI continuity tests.

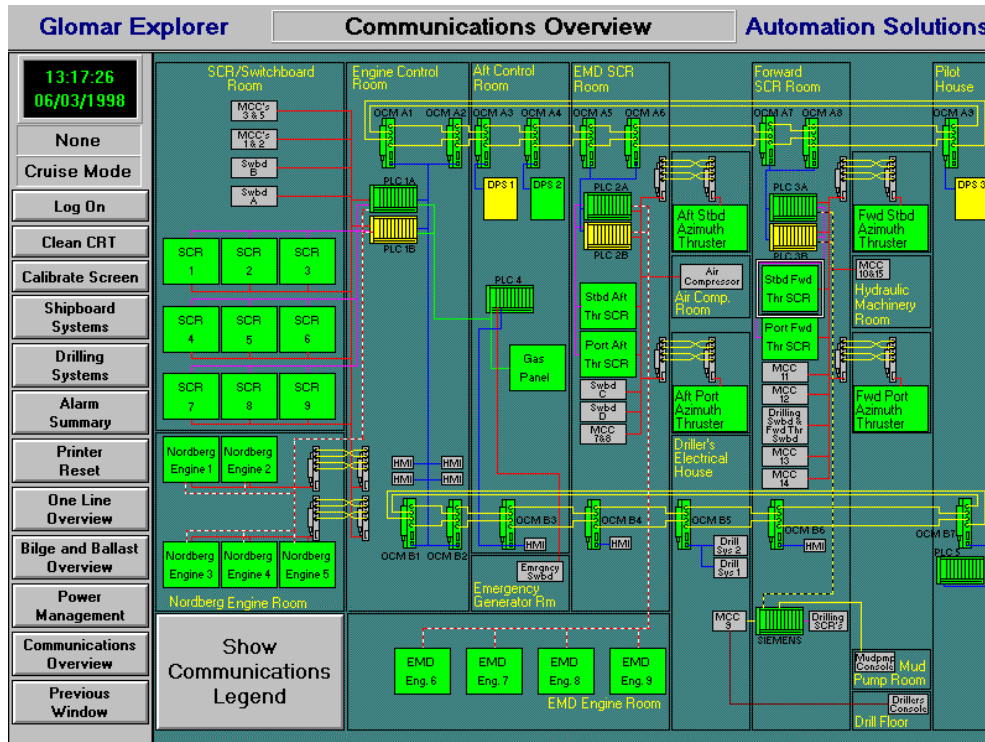

Controller Layer

Allen Bradley PLC5's are the primary controllers for the Glomar Explorer VMS. These controllers are connected directly to the Ethernet network and communication with Supervisory Layer components via Allen Bradley TCP/IP protocol. The PLCs used in critical applications such as power management or dynamic positioning have redundant CPUs. In these cases the CPU pairs also communicate for synchronization of the backup CPU over the network. All Allen Bradley Remote I/O and serial communication to subsystems such as SCRs, are connected to the both CPUs in the redundant configuration. The CPU that is currently the "Primary", the CPU that is performing control, is the communication master for the Remote I/O link and the serial communication links.

Redundant PLC 1

PLC 1A and 1B are located in the Engine Control Room. They monitor and control

- Main propulsion and tunnel thruster SCRs
- Bus A and B ties and breakers
- Bus A and B loads
- Nordberg engines and associated generators, and
- Woodward Governor 723 governor.
- MCC's

Main propulsion and tunnel thruster SCRs are critical DP control elements that must respond to Nautronix commands in a timely manner. As a result, two methods are used to interface the SCRs. DP commands and feedback are conveyed through Allen Bradley Remote I/O that is connected to

PLC 1A and B. The additional operating and performance data contained in the SCRs is communicated to the PLCs through a serial connection and the Siemens USSBus protocol.

The Nordberg engine Local Control Panels, LCPs, are also interfaced to PLC 1A and 1B via Allen Bradley Remote I/O. Through this interface the status of the engines is monitored and the emergency start sequence can be initiated. Finally, all of the Woodward Governor components, engine speed control, generator synchronization and output breaker control, and bus synchronization and tie control are interfaced to PLC 1A and 1B via a serial Modbus link.

Through I/O foreign device interfaces and communication via the network with PLCs 1A, 1B, 2A, 2B, 3A, and 3B monitor all loads and breaker and bus-tie statuses throughout the vessel. Based on this information and thresholds set by engineers through the HMIs, power management logic provides recommendations regarding generator operation to engineering and in severe circumstances assumes automatic control of the generators.

- Power management logic recommends starting the highest priority generator that is available, when the load to on-line capacity percentage is higher than the Recommend Start setpoint for an operator adjustable period of time if the largest engine/generator or line is lost on a per bus basis.
- Power management logic recommends stopping the lowest priority generator that is on-line, when the load to on-line capacity percentage is lower than the Recommend Stop setpoint for an operator adjustable period of time if the largest engine/generator or line is lost on a per bus basis.
- Power management logic automatically starts the highest priority generator that is available, when the load to on-line capacity percentage is higher than the Emergency Start setpoint for an operator adjustable period of time if the largest engine/generator or line is lost on a per bus basis.
- Power management logic automatically sheds load when the load to on-line capacity percentage is higher than the Load Shed setpoint on a per bus basis.

In order to support power management logic, which is performed each control cycle, the PLCs also calculate the power available, generator efficiency and EMD output and total load each cycle.

Calculated values for each on-line Nordberg generator.

- Real Power - KW
- Apparent Power - KVA
- Reactive Power - KVAR
- Power Factor

Calculated values for generation capacity on each bus, buses A, B, C, and D

- Real Power - KW
- Apparent Power - KVA
- Reactive Power – KVAR
- Power Factor

Calculated values for loads on each bus, buses A, B, C, and D

Jon Boaz, Automation Solutions;
Doug Osburn, Automation Solutions;
Chuck Sims, Global Marine;
Lew Weingarth, Global Marine

Power Plant

Drilling Vessel Power Plant
Controls Systems

- Real Power - KW
- Apparent Power - KVA
- Reactive Power – KVAR
- Power Factor

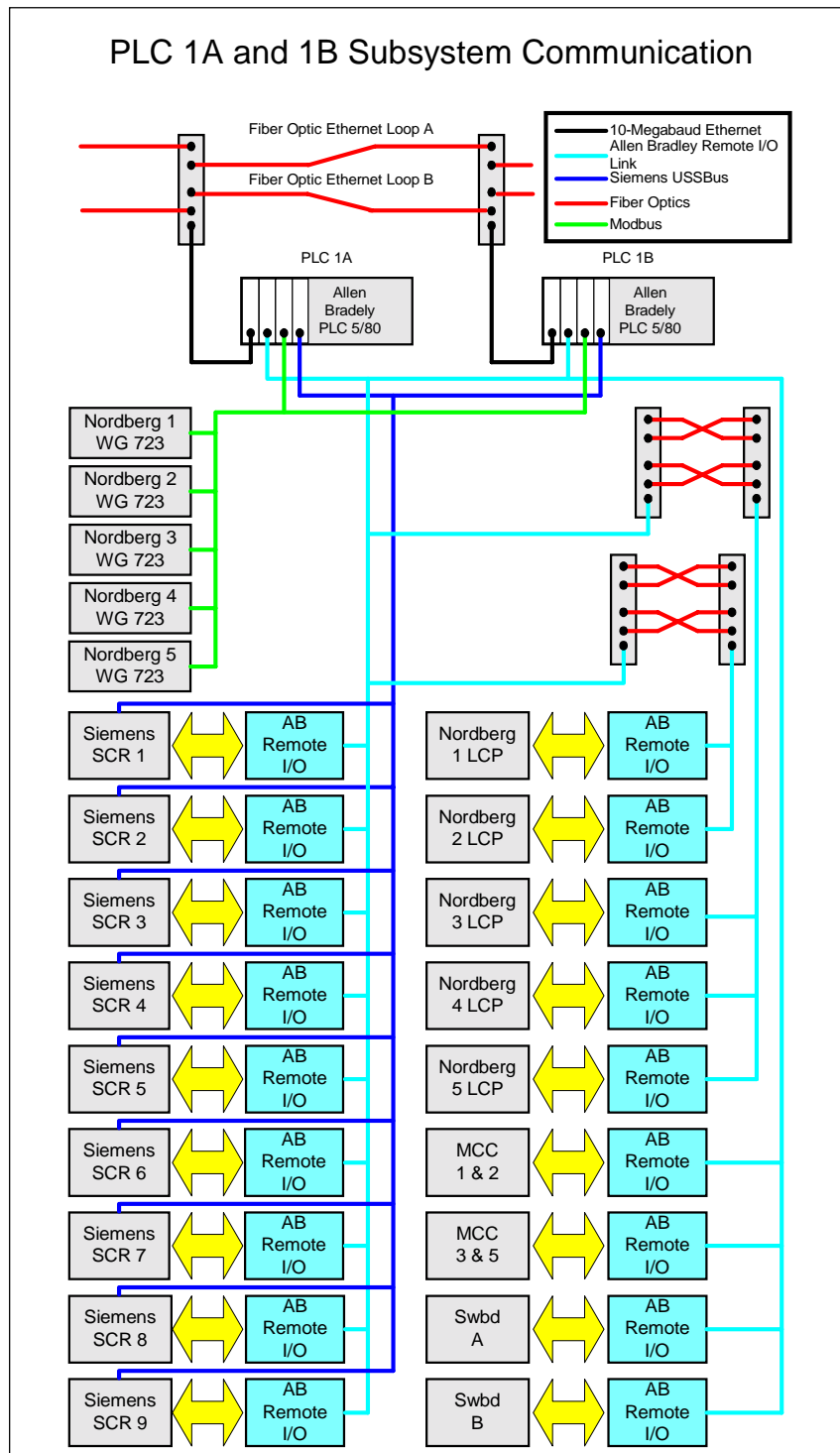

Redundant PLC 2

PLC 2A and B are located in the Afterward SCR room. They monitor and control,

- The Lips afterward azimuthing thruster control package
- Afterward azimuthing thruster SCRs
- Bus C and D ties and breakers
- EMD engines and associated generators, and
- Woodward Governor 723 governor.
- MCC's

Similar to PLC1 the speed and reliability of communication with azimuthing thruster controls is strategic to the mission of the vessel. The Lips control package for the azimuthing thrusters is connected to PLC 2A and 2B via redundant fiber optic Allen Bradley Remote I/O. The azimuthing thruster SCRs are interfaced via Allen Bradley Remote I/O and the Siemens USSBus serial protocol. PLC 2A and 2B are also interfaced to the EMD LCPs, which contain small PLCs via Allen Bradley Remote I/O and serial Modbus. Additionally the Woodward Governor controls associated with the EMDs, the EMD driven generators and with buses C and D, are interfaced to PLC 2A and 2B through serial Modbus.

Similar to redundant PLC 1, PLCs 2A and 2B communicate with PLCs 1A, 1B, 3A, and 3B to monitor allow loads, ties and breaker status' throughout the vessel. PLCs 2A and B also perform power calculations and power management logic that is identical to redundant PLC 1. This duplication accommodates circumstances in which the ties between A and B, A and D, B and C, and/or C and D may be open.

Also, in order to support power management logic, which is performed each control cycle, the PLCs also calculate the power available, generator efficiency and output and total load each cycle.

Calculated values for each on-line Nordberg and EMD generator.

- Real Power - KW
- Apparent Power - KVA
- Reactive Power - KVAR
- Power Factor

Calculated values for generation capacity on each bus, buses A, B, C, and D

- Real Power - KW
- Apparent Power - KVA
- Reactive Power - KVAR
- Power Factor

Calculated values for loads on each bus, buses A, B, C, and D

- Real Power - KW
- Apparent Power - KVA
- Reactive Power - KVAR
- Power Factor

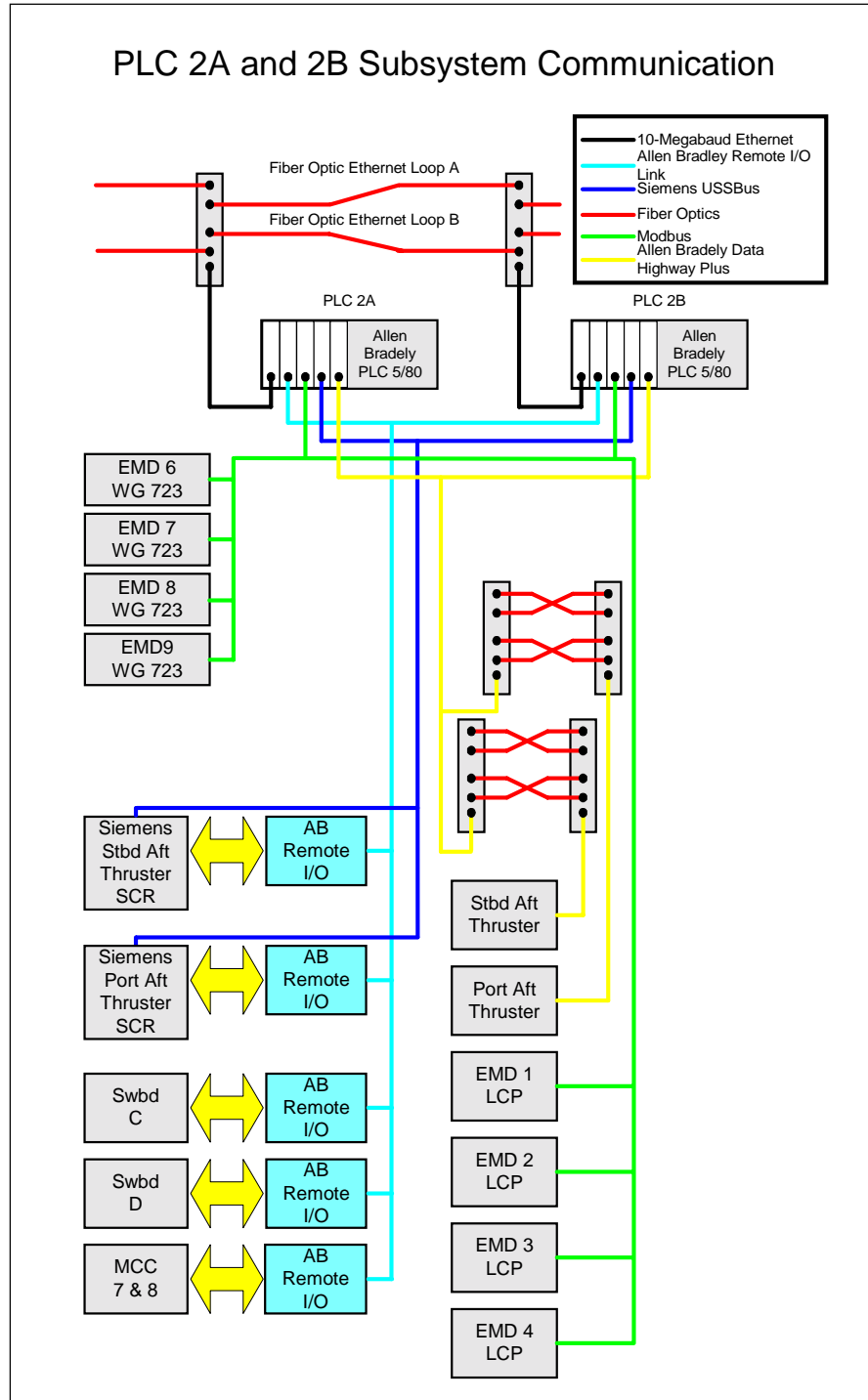

Redundant PLC 3

PLC 3A and 3B are located in the Forward SCR room. They monitor and control

- Drilling SWBD
- The Lips forward azimuthing thruster control package
- Forward azimuthing thruster SCRs
- MCC's

As with redundant PLCs 1 and 2 the connections between these components and PLC 3A and 3B are mission critical. The Lips thruster control package is connected to PLC 3A and 3B via redundant fiber optic Allen Bradley Remote I/O. The communication media between the controller located in the thruster compartment and Forward SCR Room is redundant fiber optics. The azimuthing thruster SCRs are interfaced to PLC 3A and B through Allen Bradley Remote I/O for DP commands and feedback and through Siemens USSBus for SCR performance and operating data. The redundant VMS PLC 3A and 3B interface directly to the Drilling Systems Redundant Siemens PLC pair via a dual redundant Profibus communications link. Drilling System equipment start and power management calculation data is transferred via this interface.

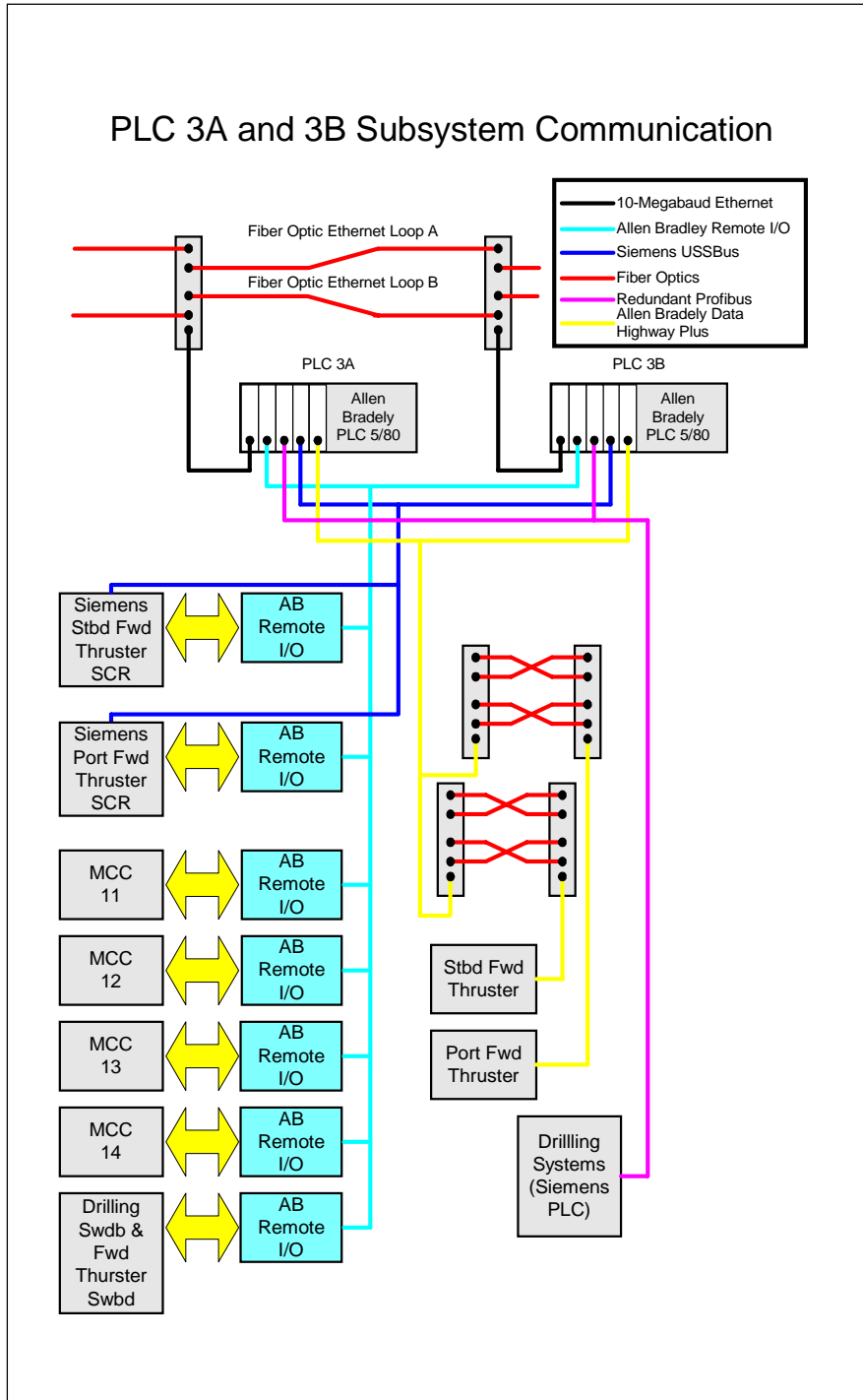

PLC 4 and PLC 5

PLC 4 Emergency Generator is located in the Afterward Pilot House and PLC 5 is located in the Forward Pilot House. These PLCs are not critical to the station-keeping mission of the vessel and as a result are not redundant. They are provided to interface pilothouse controls in order that the VMS can track vessel operations in transit.

Power Plant Control Philosophies

Recommended Generator Starts

The Glomar Explorer VMS power management philosophy is a fault predictive strategy. Redundant PLCs 1 and 2 perform logic each control cycle to determine the loading versus on-line capacity percentage that would result if the highest producing generator failed. This logic is performed for each bus. If this percentage exceeds the Recommended Start Percentage Setpoint for an operator adjustable period of time the logic recommends that engineering start the highest priority generator that is available. The engineer can decide to follow this recommendation or delay starting another generator. If the engineer chooses to follow the recommendation he can initiate an automatic startup sequence from the HMI.

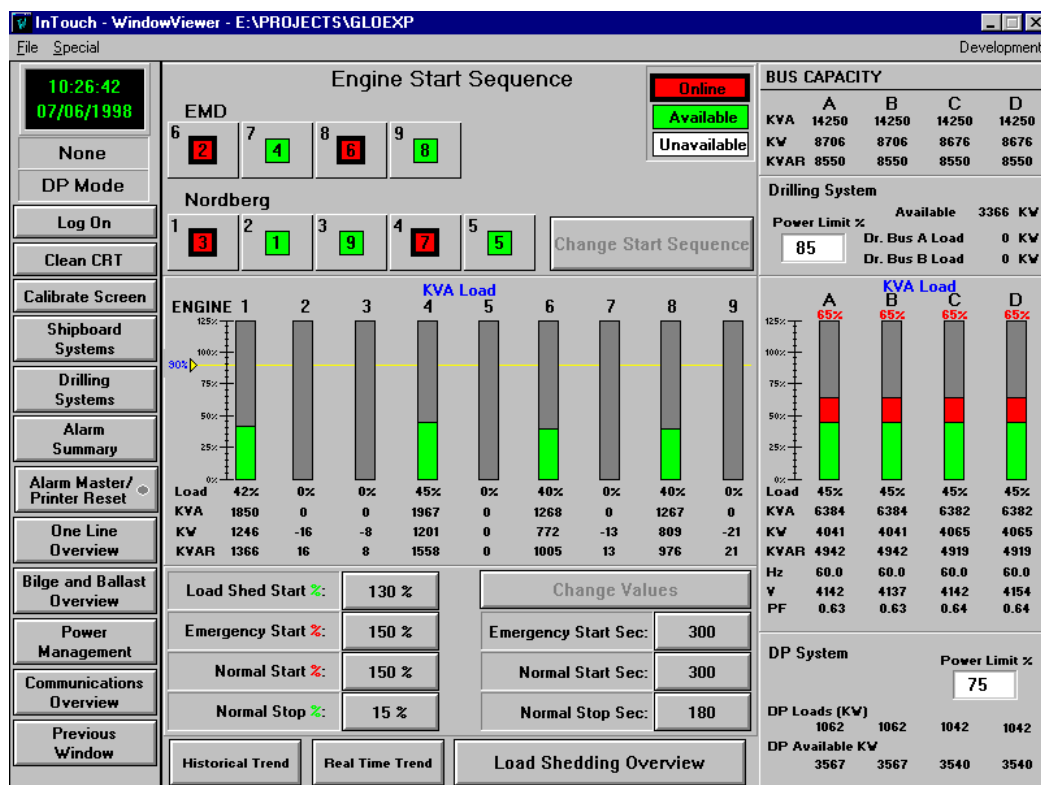

Glomar Explorer Nordberg Detail Automation Solutions

15:05:49
06/03/1998

eng
Cruise Mode
Log Off
Clean CRT
Calibrate Screen
Shipboard Systems
Drilling Systems
Alarm Summary
Printer Reset
One Line Overview
Bilge and Ballast Overview
Power Management
Communications Overview
Previous Window

Pre Start Engine
723 MODBUS Comm: Good
Crankcase Blower Vacuum: Not Running

Normal Engine Start **Normal Engine Stop**

ENGINE/GENERATOR AVAILABILITY
Engine Not Locked Out:
Eng/Gen In Remote:
Governor 723 Major Fault:
Engine Start Status:

Start Failure Reset
Available

NORDBERG 1 OFF
Opened 300 AT

Emerg Engine Start **Emerg Engine Stop**

MVA: 0.00
MYAR: 0.01
MW: -0.01
POWER FACTOR: 1.00
CAPACITY: 0%
VOLTS PHASE A: 0
VOLTS PHASE B: 0
VOLTS PHASE C: 0
AMPS: 0
RPM: 0
FREQUENCY: 0.0 Hz
PRIORITY: 1
WINDING TEMP: 130 F
STARTING AIR: 223PSI

ADJUST WARMUP TIMER: 15 MIN
ADJUST COOLDOWN TIMER: 15 MIN

ALARMS
Governor 723 Minor Fault
Governor 723 Major Fault
723/DSLCL Fault
Jacket Water Pressure Low
Starting Air Pressure Normal
Normal Cylinder Exhaust Temperature
Battery Charger Healthy
Engine / Generator Healthy
Lube Oil Pressure Low
Low Oil Pressure Shutdown Fault
Jacket Water Temperature Normal
Instrument Air Pressure Normal
Generator Cooling Water Flow Fault
Eng / Gen Moisture Sensor High

STOP SEQUENCE
De-Energize "Load" Out. To 723/DSLCL
Engine in Cooldown 15:0

START SEQUENCE
Start Sequence Not Initiated
Stop Crankcase Blower
Crankcase Blower Stopped
Pre Start
"Run" Output to 723/DSLCL
Output to Air Starter
Engine in Warmup 15:0
"Rated Speed" Output to 723/DSLCL
Engine RPM @ Rated Speed
Generator Flash
Generator Volts > 1000 V
Auto Synchronize Output to 723/DSLCL

MM/DD/YY	MM:MM:SS	Comment	GroupName	Value
06/03/98	11:27:12	Nordberg 1: Jacket Water Pressure Low	Nordberg1	ON
06/03/98	11:27:12	Nordberg 1: Generator Cooling Water Fail	Nordberg1	ON
06/03/98	11:27:13	Nordberg 1: Low Oil Pressure Shutdown	Nordberg1	ON
06/03/98	11:27:13	Nordberg 1: Moisture Sensor Fault	Nordberg1	ON
06/03/98	11:27:13	Nordberg 1: Moisture Sensor Fault	Nordberg1	ON

Previous Page ↑ Next Page ↓

Ack & Silence Alarm

Recommended Generator Stops

As with the predictive strategy above the power management logic in PLCs 1 and 2 the loading versus on-line capacity percentage that would result from the loss of the highest producing generator is compared to the Recommended Stop Setpoint. If the percentage is below the setpoint for an operator adjustable period of time and the stop of this engine/generator does not invoke a start recommendation the logic recommends the engineer stop the lowest priority generator. The engineer however, can make the decision to follow this recommendation or delay stopping the generator.

Blackout Protection

The VMS power management blackout protection includes power limiting to drilling systems, power limiting to DPS and load shedding. Between these three measures the VMS insure absolute protection against a blackout event.

Drilling Power Limiting

Power limiting to drilling are calculated in redundant PLCs 1 and 2 and communicated via Profibus to the Siemens PLCs associated with the drilling SCRs. The Siemens PLCs calculate the current limit for the drilling SCR drives and will maintain total drilling load below this value. Drilling power limiting is active at all times. The power available for drilling is based on the generation capacity currently on-line less the power used by other shipboard loads and by thrusters.

- Total Non Drilling-DPS Load = Total Load – Total Drilling SCR Load – Total SCR Load
- Drilling Power Limit = Total On-line Generation Capacity – Total Non Drilling-DPS Load – Total DPS SCR Load

To summarize the drilling power limiting equation, for a constant on-line generation capacity and a constant Non Drilling-DPS Load, as DPS power demands increase power limiting of drilling becomes more severe: the Drilling Power Limit decreases.

DPS Power Limiting

Power limiting to the DPS is only active in the DP mode. The power limits are calculated in redundant PLCs 1 and 2 and are communicated to the DPS. The DPS maintains total thrust load through the main propulsion, tunnel thruster and azimuthing thruster SCRs below the limit.

- $\text{DPS Power Limit} = \text{Total On-line Generation Capacity} - \text{Total Non Drilling-DPS Load} - \text{Total Drilling SCR Load}$

To summarize the DPS power limiting equation, for a constant on-line generation capacity and a constant Non Drilling-DPS Load, as drilling power demands increase power limiting of DPS becomes more severe: the DPS Power Limit decreases.

Load Shedding

VMS power management protects against blackouts by shedding operator selectable grouping of loads when the percent load for a bus exceeds a Load Shed setpoint on a per bus basis. Load shedding will reduce the “Total Non Drilling-DPS Load” in the power limiting calculations above. Loads that are available to be shed are organized into four Load Shedding groups by engineering, which are prioritized. The lowest priority group is shed first and the next highest second until the demand is reduced below the shedding threshold.

Power Management Summary

The Glomar Explorer management logic to provides layers of protection against blackout through power limiting and power management requests for excess on-line generation capacity. Based on the power limiting equations, as drilling and DPS loads increase to the total on-line generation capacity, the power limits to drilling and DPS SCRs become more severe. Simultaneously, however, as these loads increase relative to the total on-line generation capacity, power management logic recommends starting the highest priority generator to maintain a safety margin. If however, load increases relative to the total on-line generation capacity, beyond the Emergency Start setpoint, the next highest priority generator for that bus is automatically started to further protect against a blackout. Finally, if loads surpass the Load Shedding setpoint operator selected loads are shed until power demands are reduced below the shedding threshold.

System Performance

The integration of VMS and DPS for the Glomar Explorer and the requirements for timely responses to quickly changing power demands placed significant performance requirements on the Explorer VMS. Specifications called for the VMS to provide feedback to the DPS on commands within 500 ms. Additionally, the power management system must be able to monitor the status of all breakers and loads, monitor the availability and priority of all generators, calculate the on-line generations capacity, the capacity of each bus, the bus loads due to all subsystems and the loads associated with each load shed groups. To support all of this in a timely fashion the system must also provide for communication to synchronize redundant PLCs, communication between PLCs to which thruster controls, SCRs and breakers are interfaced, communication with the seven HMIs, communication with the data logger and communication with the three Nautronix DPS consoles.

With regard to PLC performance all control, communication and power management calculations are performed in each 100 ms cycle of the PLC CPU. In addition, the network loading on the Ethernet Data Highway due to the VMS applications alone was 3 percent. At these processing and loadings the feedback on commands from the DPS was generally within 250 ms.

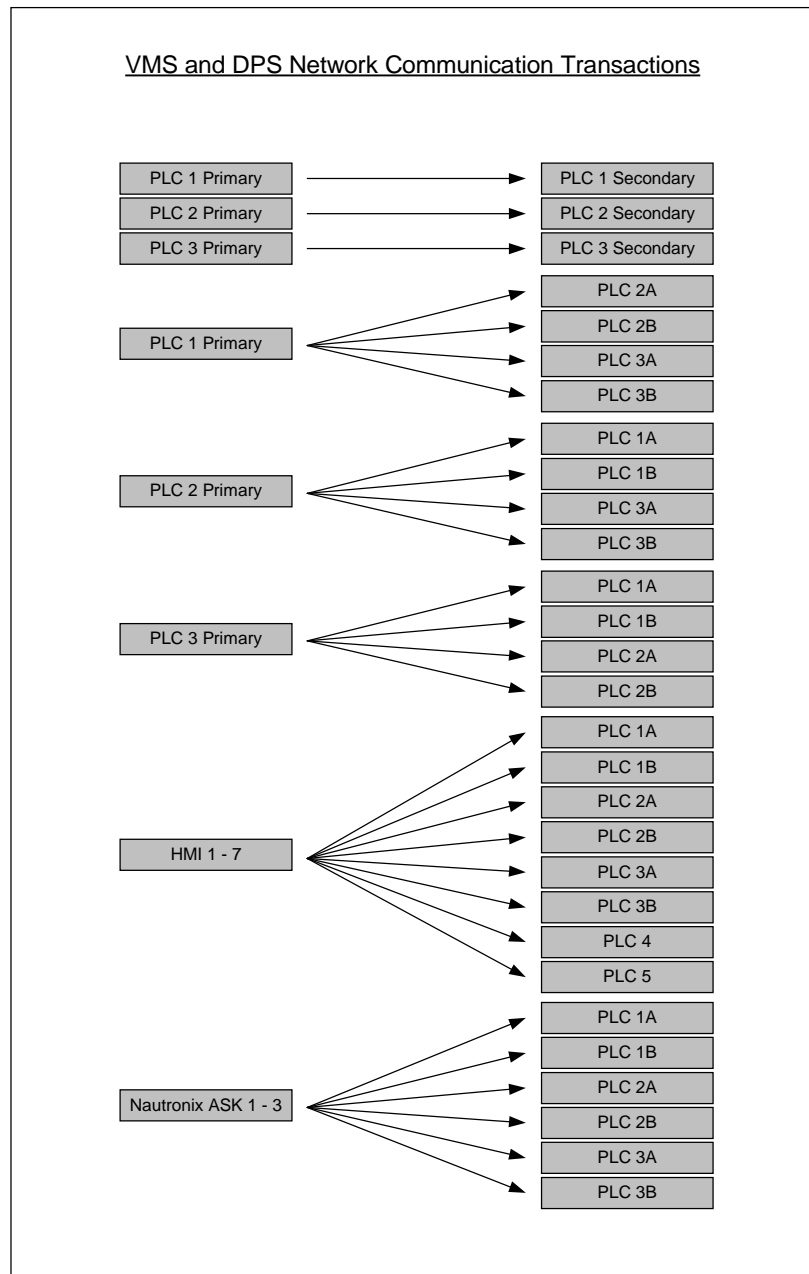

These loadings and performance figures have proven very favorable to those of Packaged systems which typically can perform individual calculations or control logic at rates of 250 ms to 1 seconds. There are also communication latencies that impact the speed of response to commands from consoles or outside systems that would be additive to these processing time. Experience indicates that power management calculations performed by these systems have typically taken more than 1 second to perform.

Additionally these systems which operate close to performance limits during periods of upset have experienced loss of data for lower priority purposes such as Data Logging.