



DYNAMIC POSITIONING CONFERENCE
October 13 – 14, 1998

SENSORS

Attitude Sensors for DP Systems

Robert Balloch

TSS (UK)

Attitude Sensors for DP systems

Introduction

The aim of this paper is to discuss the history of Attitude Sensors and their application in Dynamic Positioning Systems. It aims to review the various technical merits, practicality and price. It also aims to discuss the most important factors to be considered and what the future may hold.

What is an Attitude Sensor ?

An Attitude Sensor is a compact, self-contained Vertical Reference Unit (VRU) for measuring the motion of a platform when no fixed reference is available. The TSS Dynamic Motion Sensor uses a tri-axial array of solid-state inertial grade accelerometers and rate sensors to perform measurements of attitude and heave, with further enhancements available from the use of auxiliary inputs, namely ; GPS and compass aiding inputs.

Why do Dynamic Positioning Systems need a VRU

Roll and Pitch Data is required in real time to translate the position fixes from a GPS antenna or an acoustic transponder to some central position on the vessel. We refer to this process as GPS or APS motion compensation.

The requirement for the VRU's roll and pitch accuracy is directly proportional to the distance between the antenna or transponder and this central point.

For example, in Figure 1., for a GPS antennae say 30m above the central point, a 0.5° roll error adds about 0.25m to the position error budget - whereas a 0.5° roll error for an acoustic system working in 1000m water depth would add about 9m to the position error budget

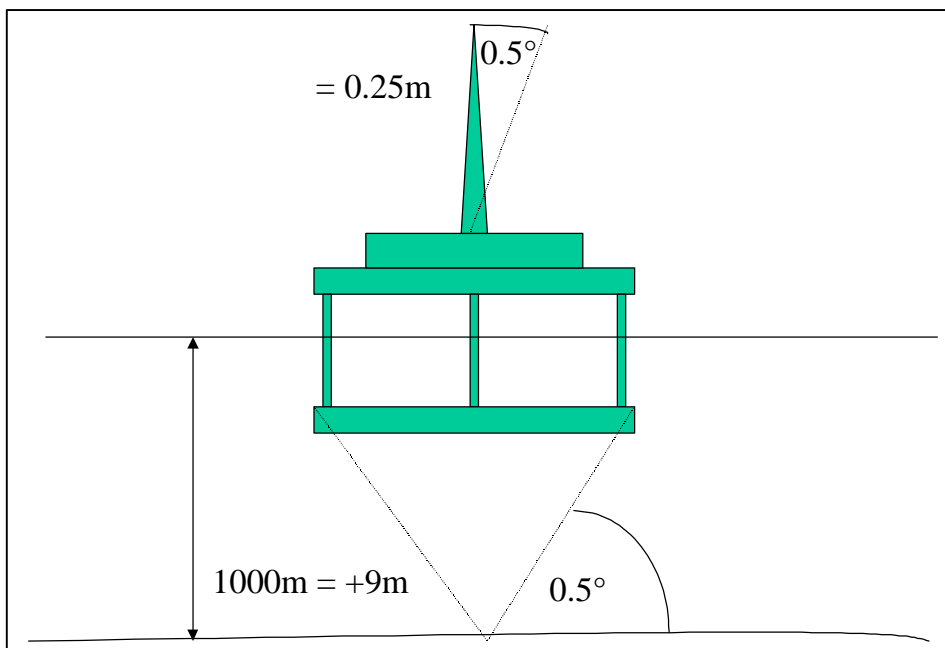

Figure 1. GPS and Acoustic Error Budget due to Roll Error

The following discusses how we actually measure the Roll / Pitch Motion of the Vessel

Vertical Reference Unit

There are several types of Vertical Reference Unit available, ranging from low cost “pendulum” type assemblies to solid state pendulum devices, Mechanical gyros, Three axis 6-DOF units and Aided Inertial systems.

Each has its own merit and each has its advantages and disadvantages, the following comparison aims to provide an unbiased overview and provide recommendations based on price, practicality and performance.

Technical Overview

Of the several types of VRU currently in use, some of the oldest designs are still very much in use today and indeed several clients are happy enough to continue procurement of such systems despite higher performance for a similar unit cost being available.

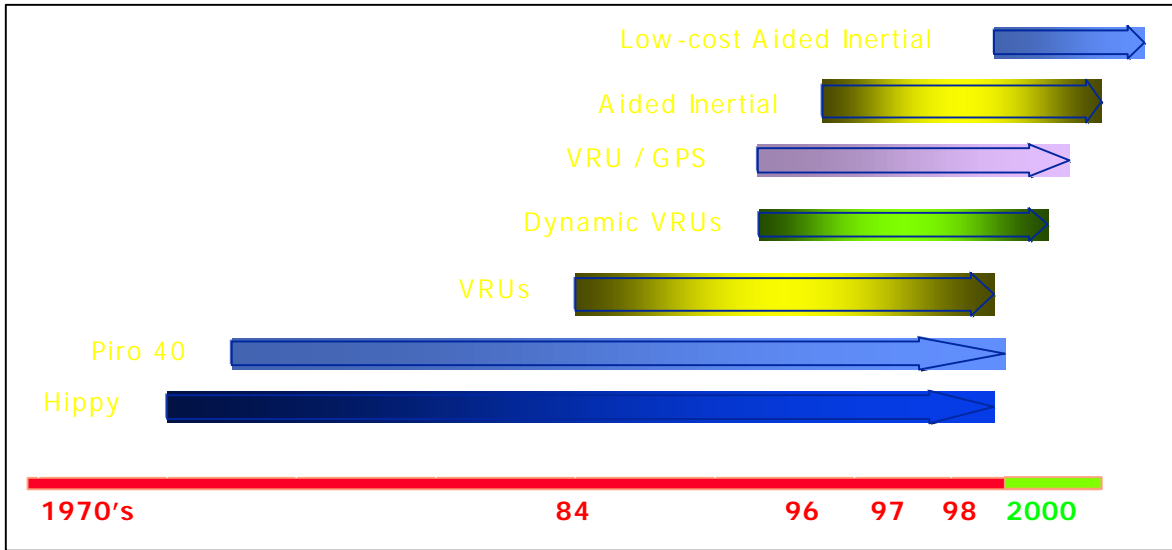

I have attempted to place each of the various types onto a matrix, obviously there is a large disparity in terms of unit cost and in terms of technology but it at least allows a simple graphic glance of where each fits in with its overall contribution to solving the DP error budget.

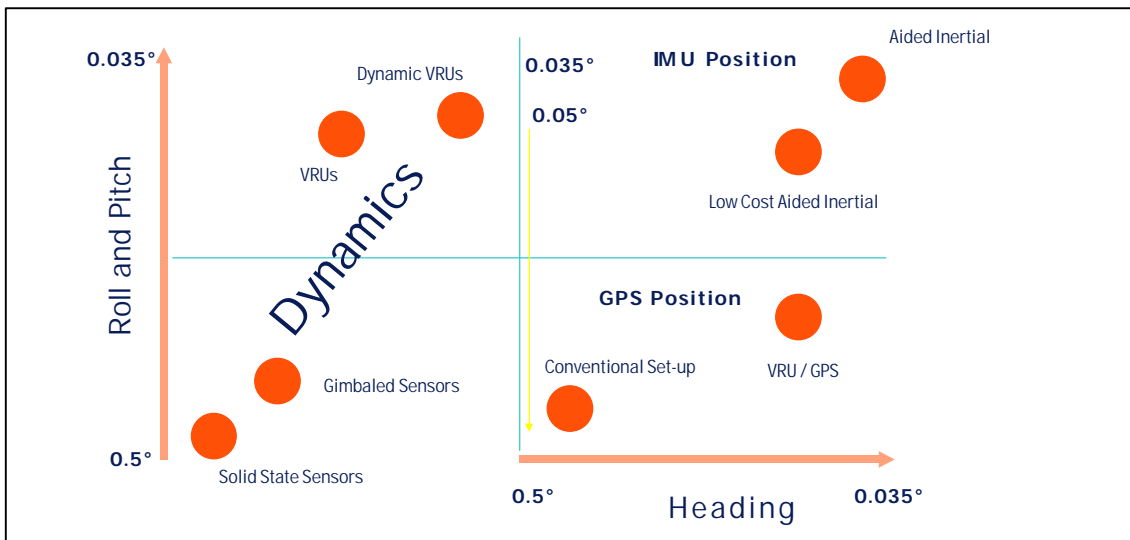

Figure 3 Contribution to correction of overall Error Budget

The following table gives an overview of the technical and commercial Advantages and Disadvantages of each technology, it should be noted that the table is by no means exhaustive and does not seek to give a recommendation either way.

	Technology	Advantages	Disadvantages
1	Inclinometers	Low Cost Good performance in Static Conditions	Low Performance Poor performance in Dynamics Low update rate and Latency
2	Fluid Stabilized Devices	Relatively accurate and reliable Tried and trusted	Size and Handling Life Cycle Costs Installation difficulties Latency
3	Vertical Reference units	Good accuracy for GPS and Acoustic Stabilization Range of performance / price sensors available Relatively low cost	No heading information
4	VRU / GPS	Heading and Position Information Good Accuracy	Relatively High Cost Heading and Position GPS dependent No “flywheel” capability
5	Aided Inertial	Complete error budget solution Immunity to GPS outages High accuracy No limitations Ethernet ability enables “total” navigation solution concept	Relatively High Cost Acceptance of existing GPS/Gyro replacement

Figure 4. Technology Table Advantages & Disadvantages

Pendulum Devices

Pendulum devices, or inclinometers, are normally applied to DP systems as a solid state unit with two sensors mounted fore/aft and port/starboard. By measuring the component of gravity in each of these axes we can derive roll and pitch. Although solid state the effect under marine dynamics can be similar to that experienced by a mechanical pendulum, i.e. follow-up errors, low accuracy and inability to cope with short term accelerations.

Fluid Stabilized Devices

The next stage is to put the pendulum type of device into a dampened environment to counter the vessel dynamics. Such units use a pick up coil that floats in a oil bath to sense rotation about primary coils that are fixed in the roll and pitch axes of the frame as shown in Figure 5. Although fairly accurate and reliable, such units have disadvantages in terms of size and handling restrictions and cost of routine maintenance.

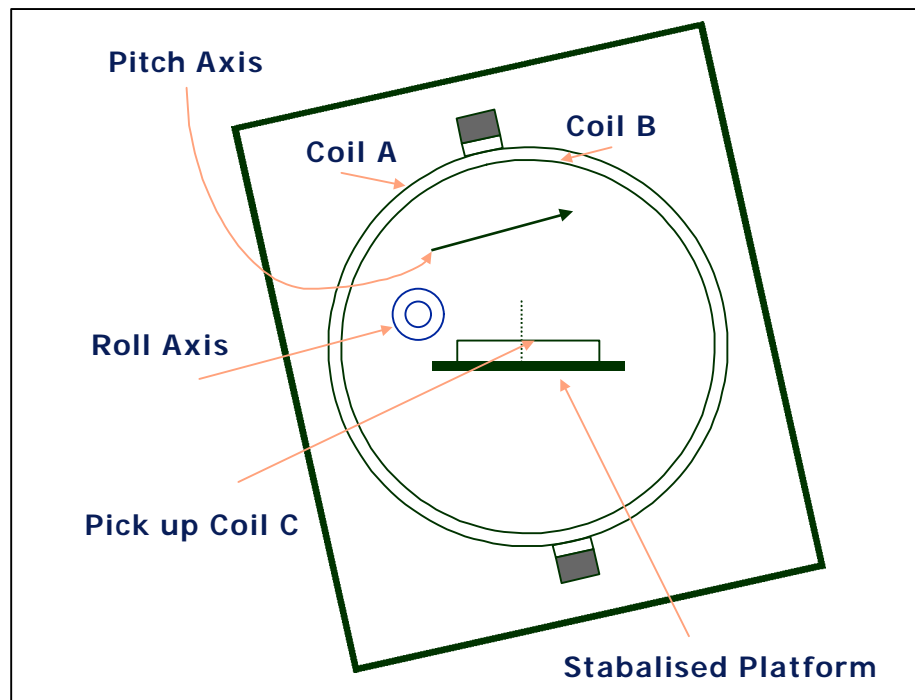

Figure 5. Fluid Stabilized Measurement Platform

Referring to Figure 5 above, alternating magnetic fields are generated parallel to the pitch and roll axes (by means of Coils A & B, fixed to the housing and perpendicular to each other). A pick up coil C, mounted on the stabilized platform (horizontal plane) measures the vertical components of the fields in the pitch and roll axes.

The induced voltage in Coil C is amplified, phase sensitive demodulated and amplified again. The Stabilized platform consists of a plastic disk that is suspended from the middle of a fluid filled sphere. The density of fluid and disk are carefully matched to each other.

Vertical Reference Units

Advances in and the availability of solid state inertial sensors heralded the development of strapdown motion sensors such as the TSS 335B. Such sensors use an orthogonal array of 3 accelerometers and 3 angular rate sensors (gyros) and deploy a vertical reference algorithm to compute Roll and Pitch.

The Linear accelerometers used in a typical VRU comprises of two major elements, the Proof Mass and the Detection and Feedback network. The sensitive part of the accelerometer consists of a thin circular piece of amorphous silicon. This material has the property of being elastic in one direction and rigid in all others. By a process of chemical etching, an inner circle of silicon is partially detached from the outer ring so that it remains supported only by a narrow flexure.

When mounted in the accelerometer, the outer ring of the silicon disk is attached to the body of the device. The central part is supported only by the narrow flexure so that it is free to deflect along the direction of sensitivity, but not in any other direction

A simplified drawing of the detection and feedback network is shown in Fig 6. Attached to each side of the proof-mass there is a light electrical coil. Each of the coils is surrounded by a magnet in a similar to the driver of a loudspeaker.

At the edge of the proof-mass furthest from the point of flexure there is a thin conductive coating that is connected through a flexible link to one input of a position detection circuit.

Two conductive surfaces on each side of the proof mass form the two outer plates of a differential capacitor – the centre plate being formed by the conductive coating on the edge of the proof mass.

Whenever the assembly experiences forces of acceleration along the sensitive direction, the proof mass will deflect away from its central position between the magnets. As a result of this deflection, the differential capacitor will become unbalanced and the position detector will send a signal to the amplifier. The amplifier will produce an output current to drive the two coils. The polarity and magnitude of the output current from the amplifier is such that it will drive the coils and the proof mass towards the centre of the magnet assembly. The magnitude of drive current that is necessary to keep the proof-mass centralised is related closely to the strength of the applied acceleration. The output signal from the accelerometer is derived from this drive current, and, after the application of linearisation, scaling and offset, is used by the sensor in the determination of attitude and heave data..

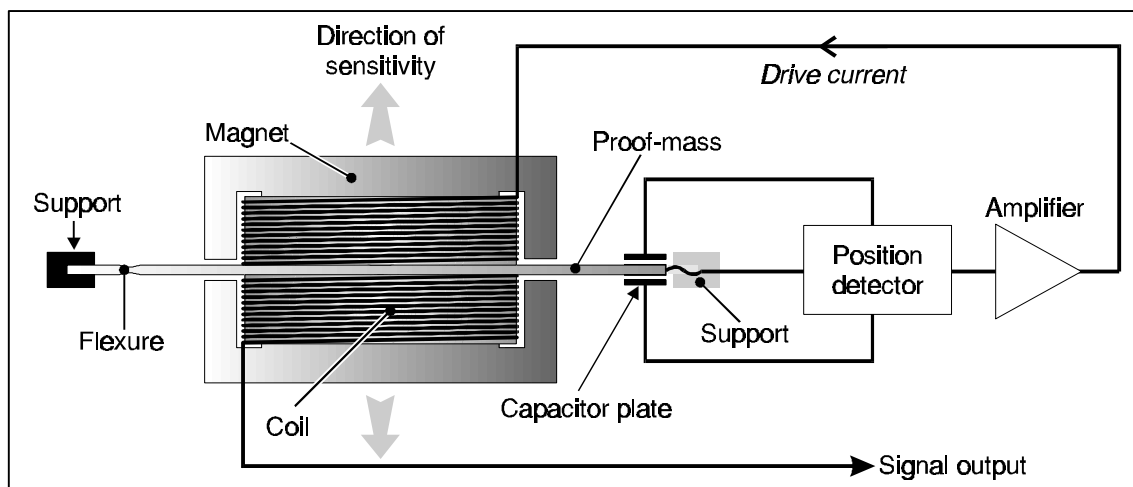

Fig 6. Graphic of an Accelerometer

Gyros

In the case of TSS sensors we use Vibrating Structural Gyroscopes (VSG's), to understand how it works it is helpful first to consider the properties of a pendulum. One property of a pendulum is that once it is set in motion, it will resist any attempts to change its plane of oscillation. If the point of suspension turns, the plane of oscillation does not rotate at the same time. The oscillating component of a VSG is a cup shaped piezo electric crystal. Fig 7 shows the 'top view', the actual crystal is very small - only a few mm in diameter - and can be made to oscillate at a very high frequency.

The two extremes of oscillation are shown a broken lines and the at -rest position through which the crystal passes within each cycle is shown as a solid heavy line. The crystal in a steady states moves in the pattern shown by A & B, upon rotation however the vibration pattern is transferred into the area C. This vibration is sensed by the secondary pick-off electrodes and de-modulated to give the rotation rates.

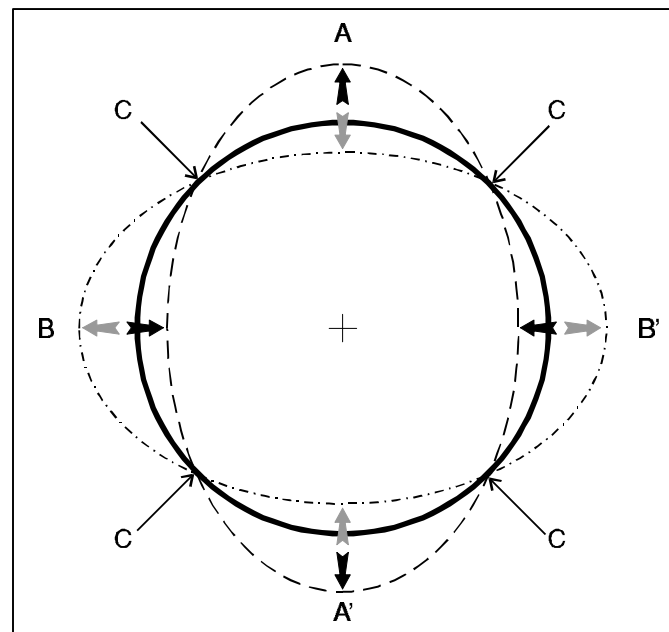

Fig 7. Graphic of a Vibrating structural gyro

Linearity, scale factor, bias and zero offset corrections are applied by the Dynamic Motion Sensor before the output from the VSGs can be used in the calculation process.

What's different in a TSS sensor

Fig 8 shows how the Dynamic Motion Sensor combines signals from the linear accelerometers, the angular rate sensors, and the aiding sources:

The accelerometers signals A_x , A_y & A_z arrive at ❶ and are converted to roll and pitch information at ❷. At the same time, information from the array of angular rate sensors W_x , W_y & W_z arrives at ❸ and is applied to the input of the integrator ❹. To eliminate the effect of short term variations the output from the integrator is compared at ❺ with attitude measurements made by the array of linear accelerometers (which do not suffer from drift). The difference between these two independent measurements is used at ❻ to estimate the magnitude of bias for each of the angular rate sensors.

The negative feedback loop formed by modules ④, ⑤, ⑥ and ⑦ serves to remove the effect of rate sensor bias.

Velocity aiding signals v arrive at ⑧ from the GPS receiver. These are used at ⑨, together with rate-of-turn information w supplied by the angular rate sensors, to derive the magnitude of centripetal acceleration :

$$A_c = v \times w$$

The result of this calculation is used at ⑩ to eliminate errors that are caused by centripetal acceleration during prolonged vessel turns.

Heading information arrives at ⑪ and is used by the DMS to provide the yaw-axis reference for the array of linear accelerometers.

Correction for earth rotation takes place at ⑫ using information supplied by the GPS and the compass system.

The output from the sensing array at ⑬ therefore has all the corrections applied and maintains the specified accuracy throughout vessel dynamics.

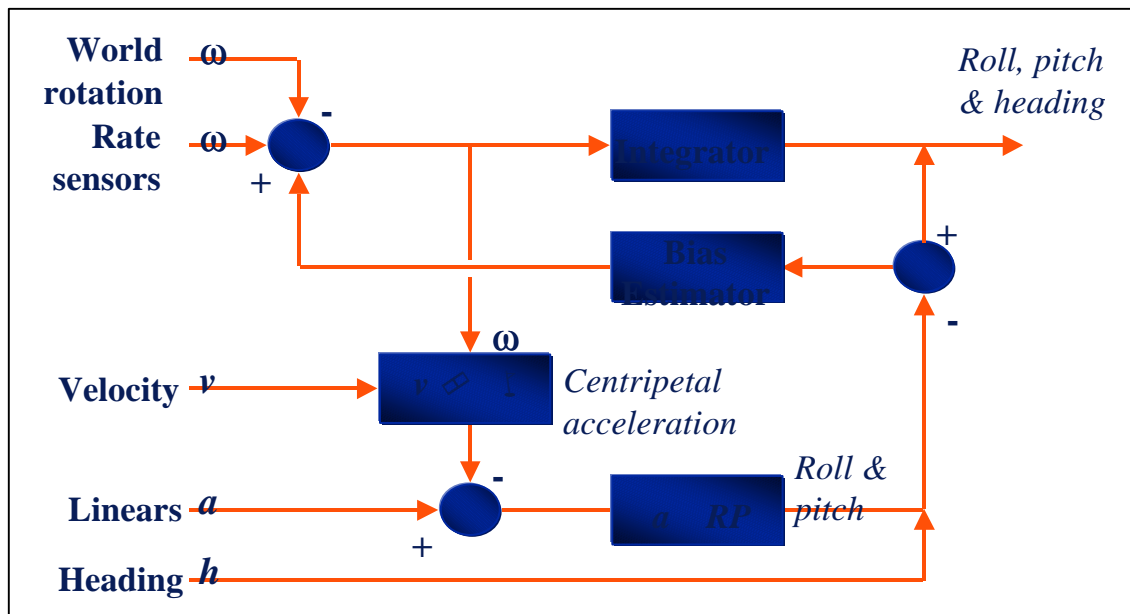

Fig 8. DMS Algorithm

Aided Inertial Navigation Systems

Figure 9 shows a functional layout of the TSS POS-MV system.

The Pos-Mv has the capability to provide an effective solution to the entire error budget, by providing solutions for Position, Heading, and Attitude that are independent of GPS availability or Position jumps. Although a relatively high cost the overall package of procuring GPS package, gyro and Attitude sensor would not be very different.

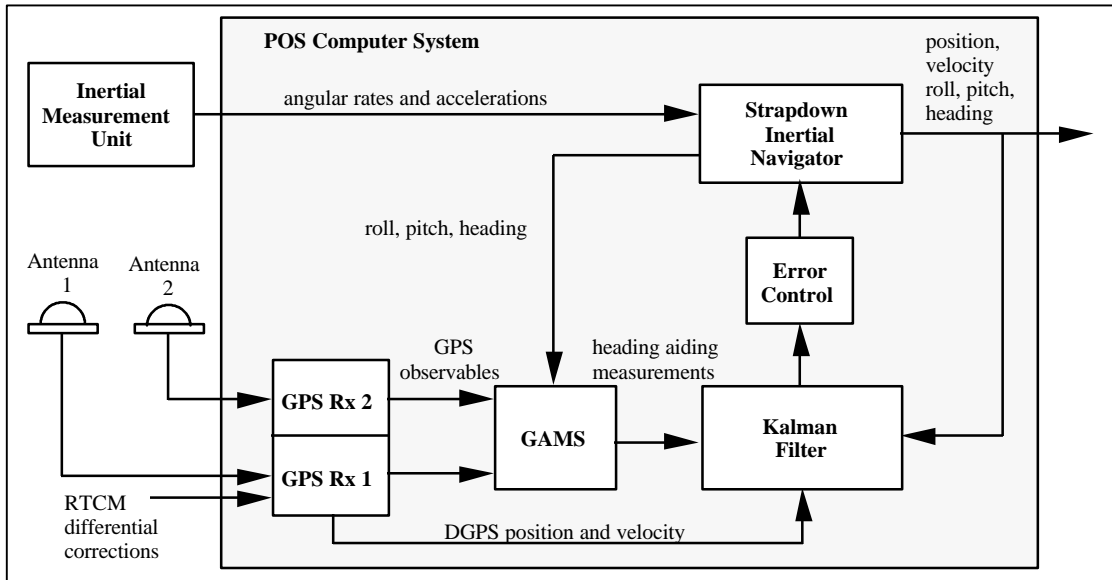

Fig 9. The TSS POS MV Functional Layout