

---

**Session 8 - Position, Environment & Attitude Sensors**

**Acoustic Positioning /Measuring Systems and  
associated redundancy and failure modes**

**Keith Vickery**

# Overview

---

- **What tools are available as an underwater DP position reference sensor?**
  - Acoustic
  - Other tools - Taught wire, Electrical Riser Angle (ERA) monitoring are covered in a separate session
  - Associated sensors - Heading, Altitude, Depth, Inclination are also covered in a separate session

# Session Agenda

---

- **Types of Acoustic Positioning Systems** 5 min.
- **Some important Acoustic Theory** 7 min.
- **Why do we design things this way?** 3 min.
- **Case Study - Dynamically Positioned Drilling** 5 min.
  
- **Questions/Answers - discussion**

# Some acoustic terminology

---

- **Beacon**  
Transponder, Pinger, Responder, Compatt, Tilt Beacon
- **Transceiver**  
Hydrophone, Transducer, Dunker, RovNav
- **Frequency Band**  
Low, Medium and Extra High frequency (LF, MF and EHF)
- **Buzz words (often used as excuses for system failure)**  
Thermoclines, Ray bending, velocity profiles, multipath
- **Noise**  
Ambient noise, Self noise, reverberation, machinery noise, flow noise, structure noise

# Types of Acoustic Positioning Systems

---

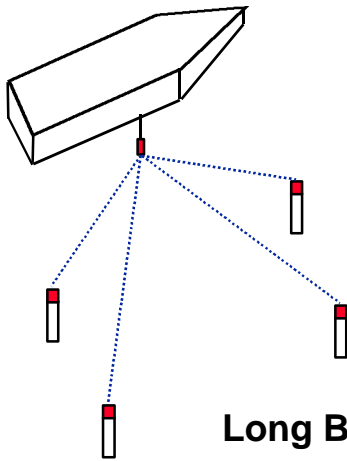

Long Baseline

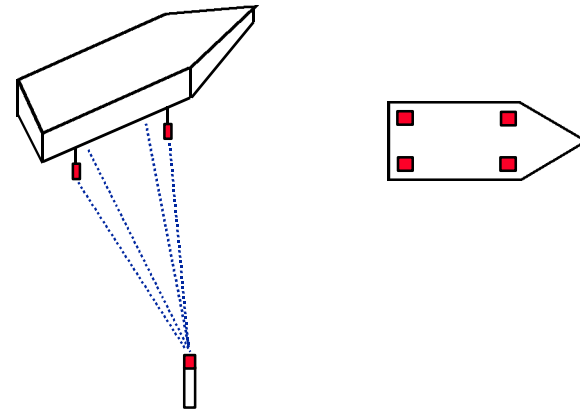

Short Baseline

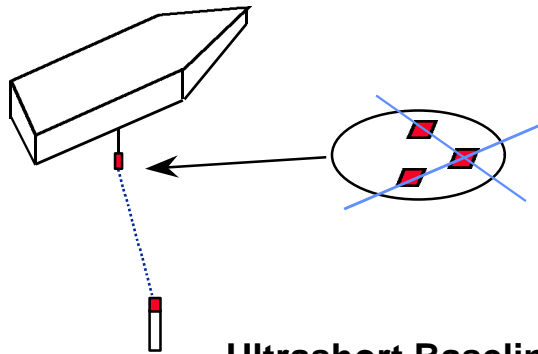

Ultrashort Baseline

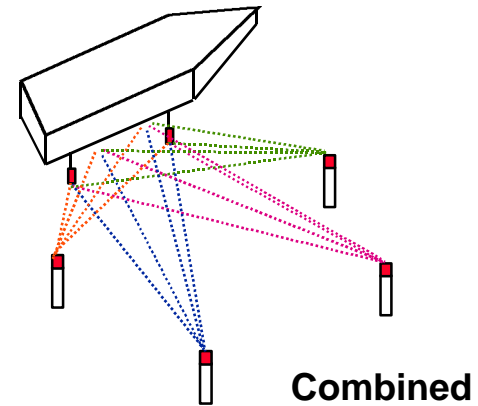

Combined

# Ultra Short or Super Short Baseline

---

This system measures a range and bearing from the surface mounted transceiver (Hydrophone) to a beacon mounted on the seafloor. A USBL system can work in pinger mode or transponder mode. The position measured from a USBL system is measured with respect to the vessel and as such a USBL system needs a Vertical Reference Unit (VRU) and (possibly) a Gyro to provide a position that is seafloor (earth) referenced.

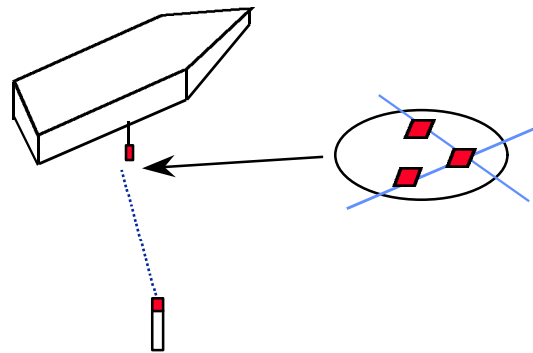

# Long Baseline

---

This system measures a position with a “range range” technique. That is a LBL system measures ranges to transponders that are at known points on the seafloor. As the system measures these ranges from known points it can then work out where the surface transducer is with respect to this seafloor “array or Grid” of transponders.

The position measured by a LBL system is seafloor referenced as such a LBL system does not require a VRU or Gyro.

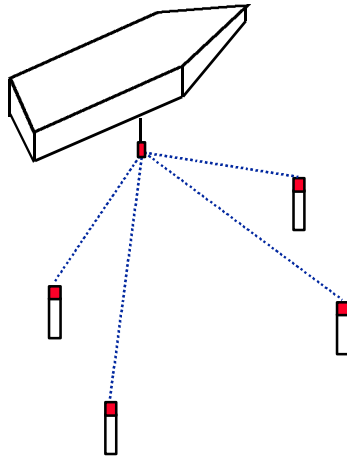

# Short Baseline

---

This system measures a range and bearing from the surface mounted hydrophones or transceivers to a beacon mounted on the seafloor.

A SBL system can work in pinger mode or transponder mode. The position measured from a SBL system is measured with respect to the vessel and as such a USBL system needs a Vertical Reference Unit (VRU) and (possibly) a Gyro to provide a position that is seafloor (earth) referenced.

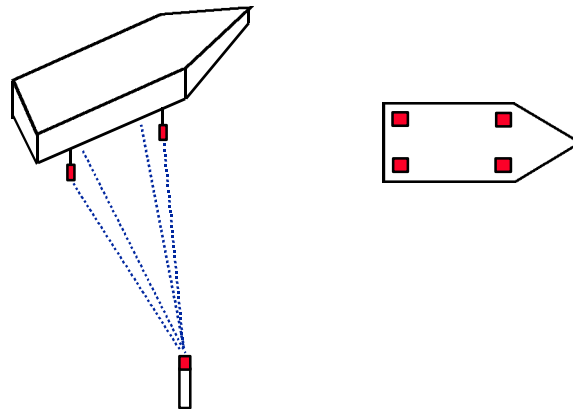

# Combined Systems

---

These systems combine the benefits from all of the above systems and provide a very reliable, redundant position reference system for DP operations. Combined systems come in many varieties:

Long and Ultrashort Baseline (L/USBL)

Long and Short Baseline (L/SBL)

Short and Ultrashort Baseline (S/USBL)

Long, Short and Ultrashort Baseline L/S/USBL

# In practice these simple combined concepts look like this:

---

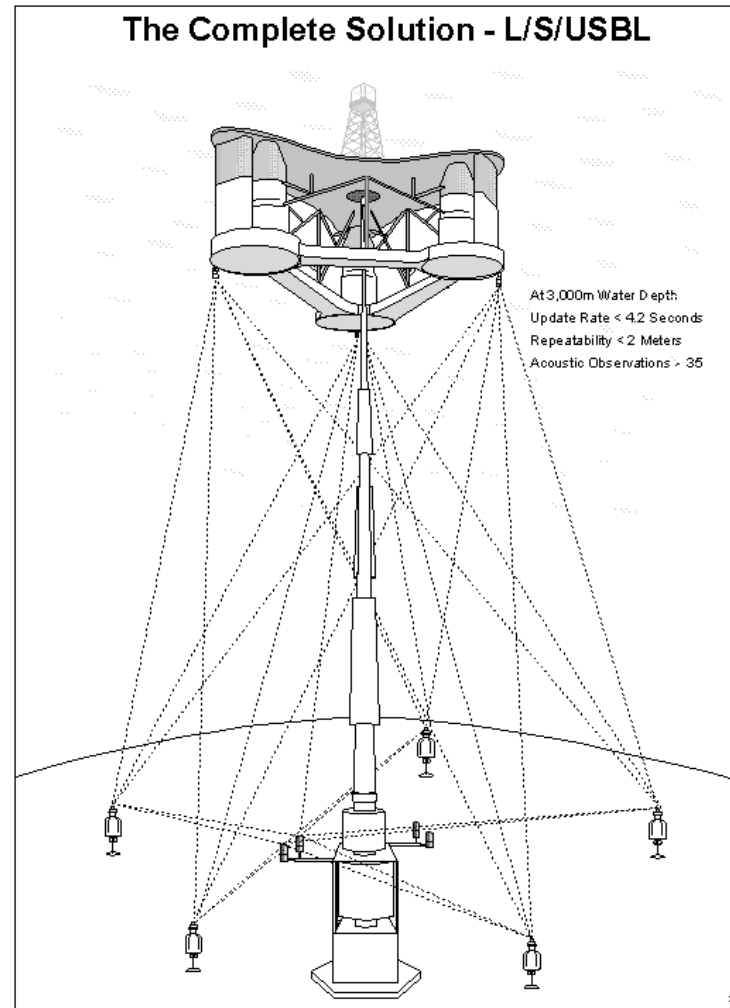

# Or like this:

## SYSTEM BLOCK DIAGRAM

Integrated LUSBL System Block Diagram

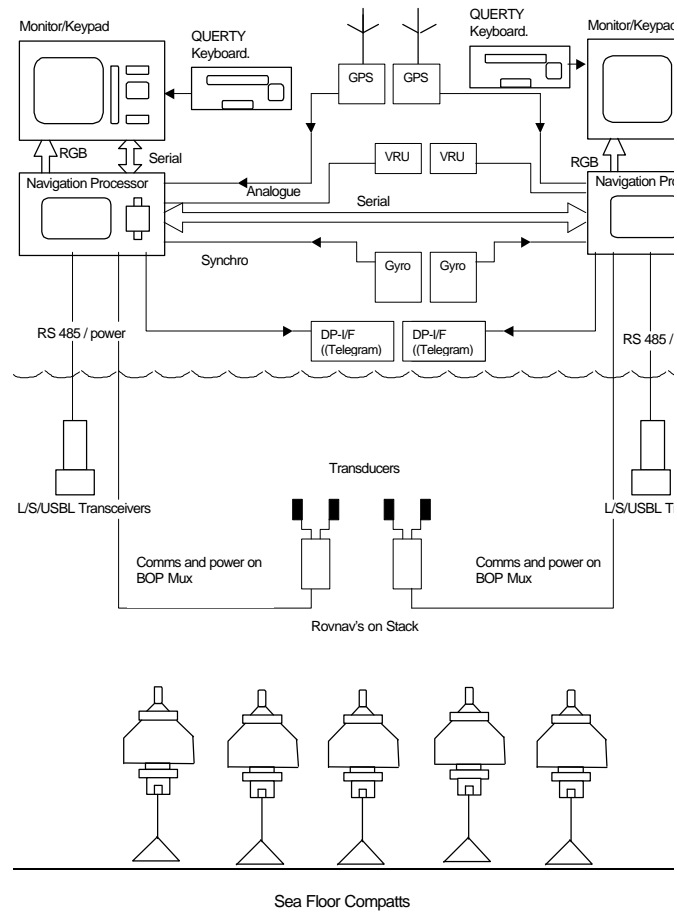

# Important (Basic) Acoustic Theory

---

- **Optimum frequency Bands**
- **Transmission loss**
  - Divergence Loss - Spreading
  - Transmission Loss Anomaly - Attenuation
  - Boundary Loss - Bounce
  - Refraction loss - bending (distortion)
- **Noise**
  - Ambient
  - Self noise
- **For future study or reading look at:**
  - Range resolution
  - Frequency, bandwidth, pulse width, Source level
  - Detection, validation - hard limiting
  - Uncertainty in speed of sound in water

# Optimum frequency Bands

---

	Frequency	Max Range	Typical LBL Accuracy
Low Frequency (LF)	7.5 - 15kHz	10 - 12Km	2.5-5m
Medium Freq. (MF)	18 - 36kHz	2.5 - 3.5Km	0.25-1m
Extra High Freq.. (EHF)	50 - 110kHz	<1Km	<0.05m

Please note that the accuracy's shown above are for static sampled positions. For dynamic un-sampled but filtered positions a consideration for update rate and motion has to be made. This could decrease the estimated accuracy by a factor of two.

# The Sonar Equation

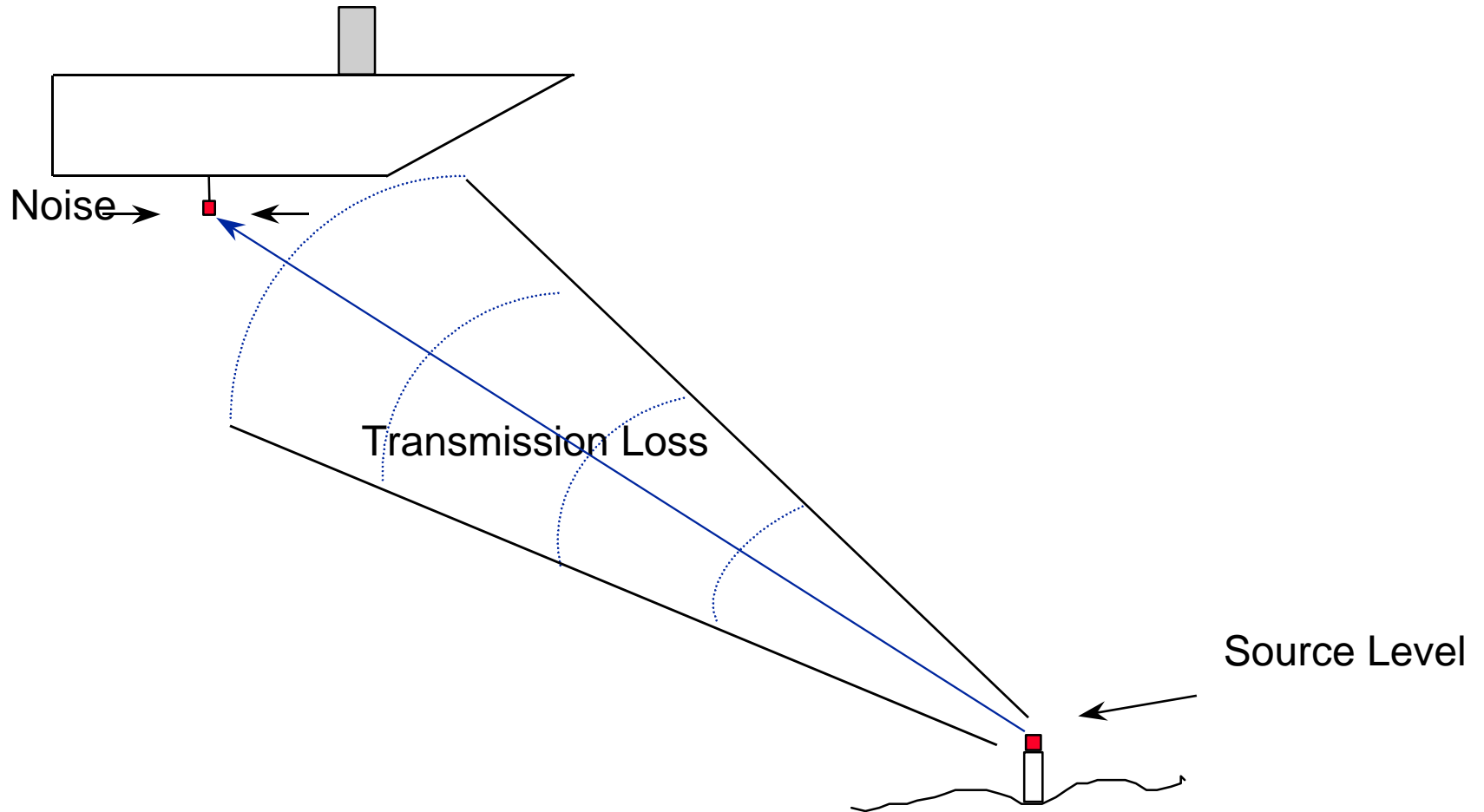

# Transmission loss

---

“Transmission Loss” is the amount of energy lost as an acoustic signal travels through the water column. The total transmission loss is a sum of the Spreading loss and the Attenuation Loss. Together, the spreading and attenuation may be expressed as:

$$TL = 20 \log_{10} R + @ R$$

where TL = one-way transmission loss in dB

R = range in meters

@ = attenuation coefficient in dB per kilometer

Typical values for the attenuation constant at a temperature of 24 degrees centigrade over the frequency band used for acoustic positioning are:

Frequency (kHz)	10	30	50	70	90
(dB/Km)	1	7	15	22	30

# Total Transmission Loss versus Frequency

---

Frequency kHz	10	20	30	40	50	60	70	80	90	200
<b>Range meters</b>										
10	20	20	20	20	20	20	20	20	20	21
30	30	30	30	30	30	30	31	31	31	32
100	40	40	41	41	42	42	42	43	43	46
300	50	50	52	53	54	55	57	58	59	67
1,000	61	63	67	70	75	78	82	85	90	115
3,000	73	79	91	100	115	124	136	145	160	-
10,000	90	110	150	180	-	-	-	-	-	-
15,000	90	129	189	-	-	-	-	-	-	-

# Noise

---

**If anything sticks please (please) let it be this section**

**Noise is usually the biggest problem encountered when using acoustic positioning systems. It can be very expensive:**

**Where does noise come from?**

**Ambient**

**Self noise - (acoustic pollution)**

# More Noise - Thruster's!!

---

- Propulsion noise
- Machinery Noise

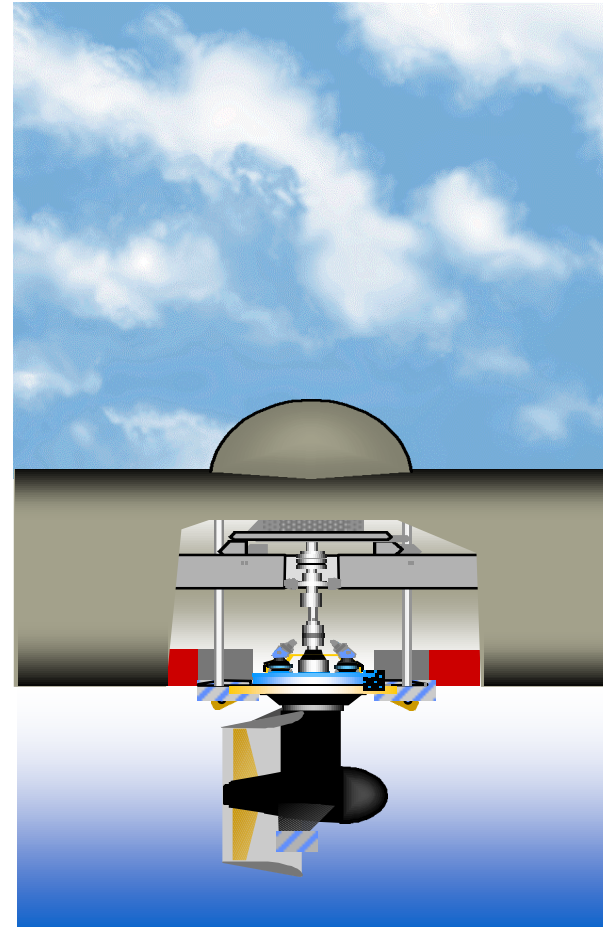

# Even More on Noise

---

- Flow noise
- Reverberation
  - Structure noise

If in any doubt about noise  
**GET IT MEASURED!!**

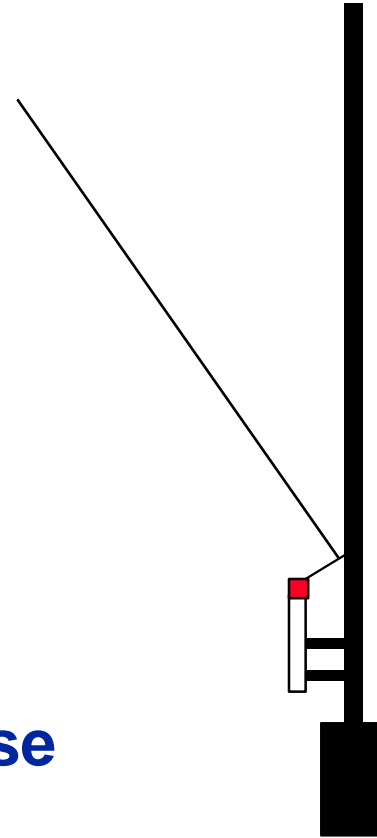

# Signal to Noise

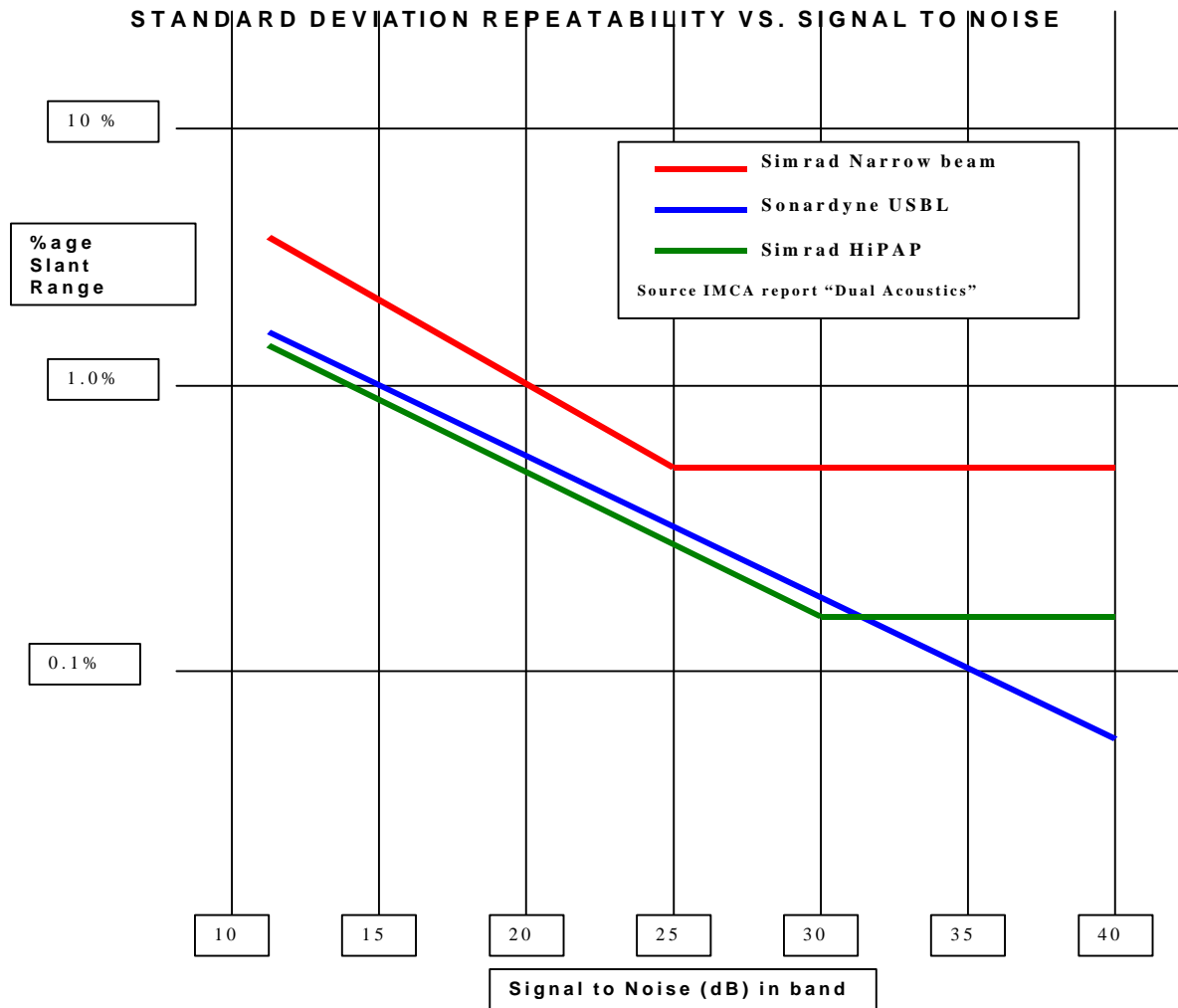

# Hardware Design

---

- **Why do we design hardware this way? A few examples:**

Transducers

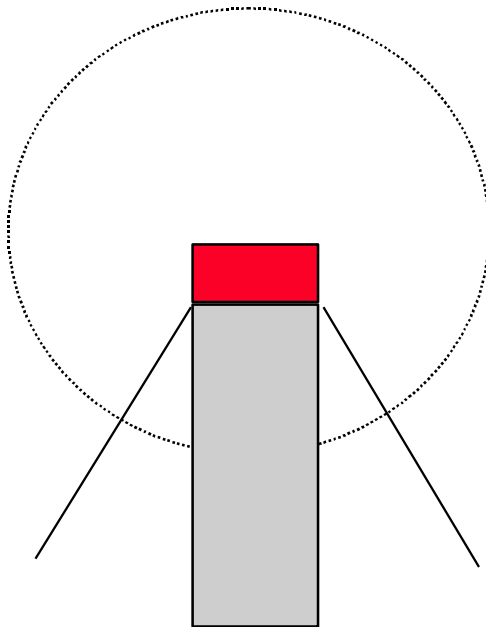

Battery Packs

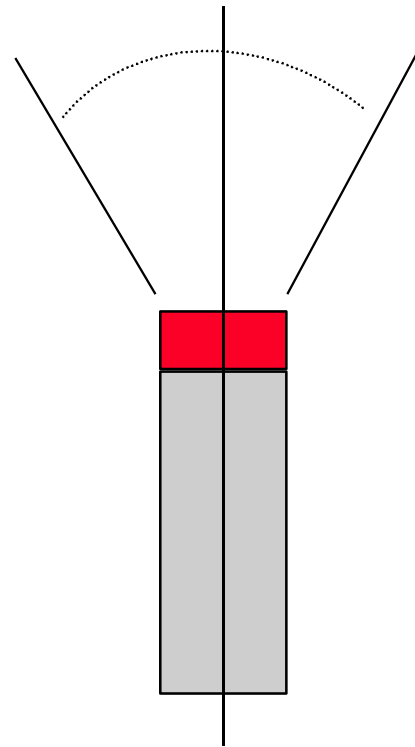

Source Level

# Case Study - Deep Water DP Drilling

---

- **DP System requirements**
- **Noise**
- **Update Rate**
- **Position Tolerance**
- **Redundancy**

# Deep Water DP Drilling

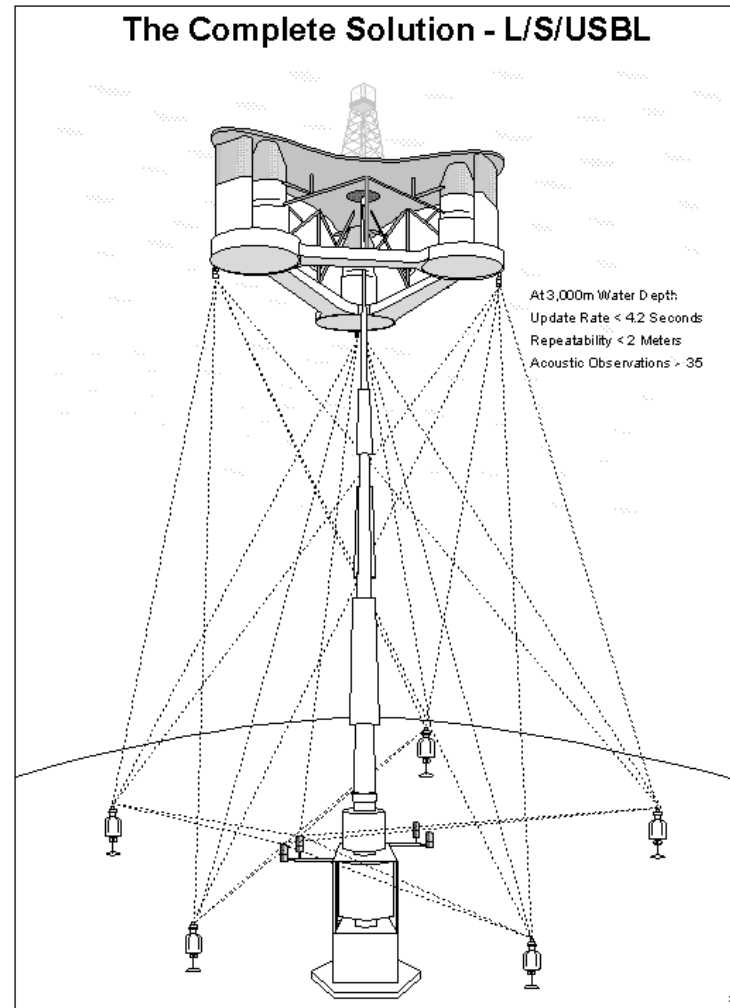

# What's new

---

- **DSP - higher range resolution, better signal to noise, many more channels**
- **More combined systems**
- **Deeper water, more intelligence**
- **Higher update rate - ping stacking?**
- **more survey into operators hands**

# Summary

---

After the perfect theoretical world comes the  
*practical real world:*

When working with acoustic positioning systems offshore you can guarantee that you will have some situations that cause problems within the acoustic positioning systems. The skill of the operator and the design of the system will (hopefully) eradicate the majority of these, for most operations.

1. “All of a sudden we just lost tracking!!”

Ever changing geometry will result in changes in the reverberation (multipath) conditions.

2. The Mexican jumping bean syndrome - “The dam ROV is jumping all over the screen!!”  
Ever changing geometry will result in variable ranges, beam patterns, signal level variations and presentations of noise sources.

3. “When the weather picked up we lost acoustics completely, XXXX!!”

When thruster power levels increase usually noise levels and aeration increase in the water column. This results in low signal to noise and high attenuation of acoustic signals. Complete a noise trials in a realistic situation.

4. “Who left that XXXXXX pinger on the stack?”

More and more acoustic positioning systems are being used closer and closer together. Be aware of what other systems are operating around your project. Time share if necessary.

# Where to get more information

---

- Other training sessions
- Books, Papers, electronic sources
- Manufacturers, Survey Co's