

Marine Technology Society

Dynamic Positioning Conference

21 - 22 October, 1997

Session 2

DP Classification

Classification of Control and Power Systems for Dynamic Positioning

By: Andrew Munden
Senior Engineer
ABS Americas (Houston)

Session Planner

Harris Knecht: *Exmar (Houston)*

Classification of Control and Power Systems for Dynamic Positioning

Introduction

The objective of a dynamic positioning control system is to counteract the constantly varying forces incident upon the vessel in such a manner that it will either maintain an operator specified position and heading, or move along a desired track. This can be achieved by either centralized manual control of the vessel's thrusters or by automatic response to the variations of the environmental conditions. The forces which must be counteracted are those due to wind, waves and current; the required accuracy and reliability of position depends upon the particular operation being carried out by the vessel.

Typically the position holding accuracy which can be maintained in rough weather by automatic systems is in the region of 3 to 5 metres. Whereas the maximum environment which the vessel can withstand is purely a balance of the available thruster power against the effect of the environmental forces on the ship, the accuracy of position is dependent upon the accuracy of the various sensors which input information to the controller, the precision of the mathematical model used by the controller, and the speed of response of the thrusters (in both force and direction) to the demands of the controller. Reliability of position and heading keeping capability is of course dependent upon the reliability of the individual components of the system. In real terms, complex components such as the controllers, sensors and their power supplies require redundancy in order to achieve system reliability. For a DP system, adequate redundancy means that the system has the ability to maintain or restore its function when a failure has occurred.

Dynamic Positioning Control

Any vessel is subject to six modes of motion. It is only necessary, however, to control three of these to maintain the vessel's position and heading: surge, sway and yaw. On the other hand it is necessary to carefully measure pitch and roll in order to compensate for errors which may be induced in the vessel's sensors by these motions. Finally heave may also be monitored, not for the benefit of positioning the vessel, but for example to provide heave compensated drilling or diving systems.

The DP control system controls surge, sway and yaw by making demands upon the vessel's propulsion system, i.e. the speed or pitch of main propellers and tunnel thrusters, and the speed or pitch and azimuth of compass thrusters. Operator input requirements for the vessel's heading and position are processed by the controller to provide varying thrust and azimuth control signals to the vessel's thruster and main propeller systems. The computer always allocates optimum thrust to whichever propeller systems are in use, taking into account possible interference between thrusters, or between thrusters and other equipment, e.g. underwater sensors, umbilical, etc.

To control the vessel's heading, the controller uses data from one or more gyrocompasses; to control the vessel's position, data from at least one position reference system is used. Typical position reference systems may be based for example upon satellite transmissions, hydroacoustic transponders deployed on the sea bed, direct line of sight microwave links between the vessel and fixed positions on shore or on a platform, or taut wire systems. Errors introduced into the reference systems by pitch and roll are compensated for by devices known as vertical reference units (VRUs). The actual environmental forces on the vessel are measured by means of wind sensors which give signals for strength and direction. Sea current and wave forces however are not measured but calculated from the vessel's mathematical model. The result of this calculation is a combined, "unknown" force which in fact takes into account not only current and wave forces, but errors in thruster force specification, wind sensor operation, etc.

The use of the above systems allows deviations from the wanted heading or position to be detected, displayed for the operator, and used directly by the controller to automatically maintain the desired vessel state. Automatic control may also be combined with manual control in various ways:

- Automatic - retains position and heading.
- Manual - position is controlled via a joystick, and heading is controlled via a rotating knob.
- Mixed - Selecting auto for surge, sway or yaw allows the system to automatically control that parameter. For example selecting automatic yaw control will maintain the current heading, while the operator has manual control of position via the joystick.

The basis for the algorithms contained in a DP controller is its internal mathematical model of the vessel. This is a hydrodynamic description of how the vessel reacts to forces acting upon it: the measured wind force, and the thruster forces calculated from measured propeller pitch/rpm and direction. The output from the model is an estimate of the vessel's heading and position. The model is not in fact a fixed, static entity, but is continually tuned to the prevailing conditions. This is achieved by a technique known as Kalman filtering whereby the vessel's true heading and position as measured by the gyrocompasses and position reference systems are compared to the values which were predicted by the model. The differences are then used to update or "tune" the model to the actual situation.

The mathematical model of the vessel together with the Kalman filter provide the following benefits:

1. Optimal noise filtering of heading and position measurements.
2. Optimal "mix" or combination of data from the different reference systems via an algorithm which puts different weighting upon the measurements according to each system's individual quality (accuracy, stability, repeatability).

3. In the absence of position or heading reference measurements, the model provides a very accurate “dead reckoning” mode. This means that the system is able to perform accurate positioning for several minutes without any position reference system.

The controller uses the mathematical model to calculate the thrust force required in order to keep the vessel at the wanted heading and position. In control terminology the desired heading and position as input by the operator are called “setpoints”. The differences between these setpoints and the filtered position data (together with the differences between wanted and actual velocities) are calculated and multiplied by gain factors and the result is the force demand required to stop the vessel’s movements (or keep the wanted speed), and to keep the ship in the wanted position and heading. The gain factors are calculated to optimize the station keeping capability without high fuel consumption.

In order to respond to wind forces as quickly as possible, a concept known as “feed forward” is used. This means that the controller doesn’t wait for the vessel’s reaction to wind forces to be measured as a deviation from the wanted heading and/or position, but applies thrust to counteract the wind induced forces as soon as they are detected by the wind sensors.

Finally the thruster control function generates the control signals to the thrusters to obtain the force and moment required for the position and heading control. The function allocates the force and direction commands to the different thrusters based on the vessel’s thruster configuration and parameters (thruster types, maximum available force etc.). Feedback signals from the thrusters allow the controller to compare demand with actual azimuth/rpm. Failure to reach a commanded angle within a set time period, which allows for the response time of the thruster, will result in an alarm. This may be due to failure in the thruster, or simply an error in the feedback.

ABS Classification

The American Bureau of Shipping (ABS) publishes the “Guide for Thrusters and Dynamic Positioning Systems”, which contains detailed requirements for the Classification of such systems. There are four available notations which may be assigned to a vessel depending upon the degree of sophistication and redundancy of the systems provided. In order of increasing sophistication and redundancy these are DPS-0, DPS-1, DPS-2 and DPS-3. Table I is a comparison of the Classification requirements for DPS-0, DPS-1, DPS-2 and DPS-3 notations with respect to control reference and power systems.

For DPS-0, a centralized manual position control system with automatic heading control is required. This must be supplied with data from one position reference system, one wind sensor, and one gyro compass. These systems are to be located at a main DP control station where the operator is aware of the external environmental conditions and any activities relevant to the DP operation. There is no redundancy requirement associated with this notation, and the application

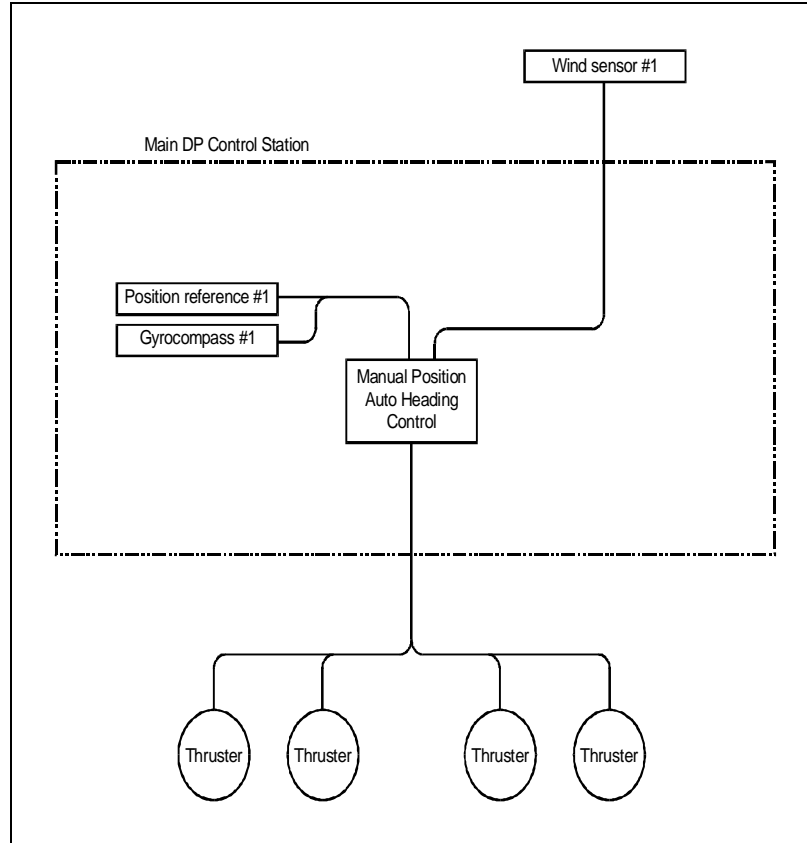

would be operations where the positioning function is not considered to endanger human lives, or cause major damage in case of failure. An example of a DPS-0 system is shown in Figure DPS0.

Where damage or pollution of small consequence may occur in the event of a failure of the positioning capability, the notation DPS-1 is perhaps more suitable. Here, although there is still no requirement for comprehensive redundancy, the manual position/auto heading control system is essentially a back-up to a fully automatic system, which has redundancy in the sensors, and a more secure power supply. The position reference sensor, wind sensor, and gyro compass required for DPS-0 are provided in duplicate. Figure DPS1 shows such a system.

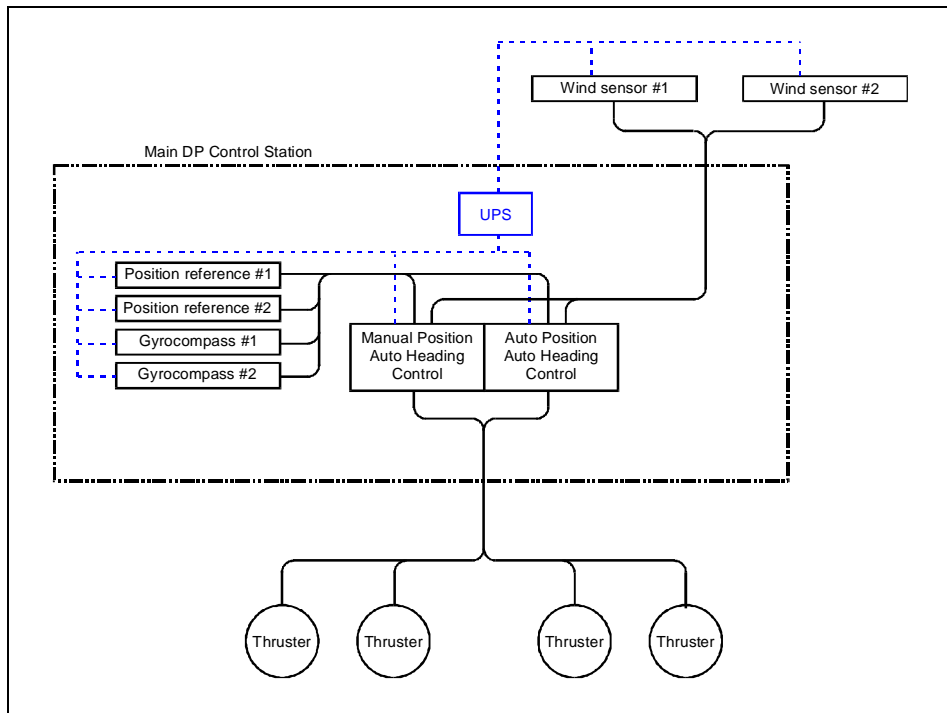

Figure DPS1: Example DPS-1 Control System Arrangement

When the consequences of a loss of position become more severe, careful attention must be paid to the effects of failures in the system. The notations DPS-2 and DPS-3 are intended for such situations, the essential difference being that whereas both systems will withstand any single component failure, the DPS-3 system will also withstand the complete loss of any single compartment (and its contents) due to fire or flood. Ability to withstand a failure must be proved by means of failure modes and effects analysis. From the point of view of the control systems this means that DPS-2 and DPS-3 compliant vessels must have two fully automatic systems, together with the manual position/auto heading back-up system carried over from the basic DPS-0 requirements. In the event of failure of one of the automatic systems, control should be automatically transferred to the standby automatic system. An additional position reference system is added over those required for DPS-1, giving a total of three, at least one of which must operate on a different principle from the others. The presence of three position reference systems allows their outputs to be compared and, where one indicates a radically different position from the others, an out of range alarm to be generated. Such signal processing techniques are a requirement of DPS-2 and DPS-3. A typical DPS-2 system is shown in figure DPS2.

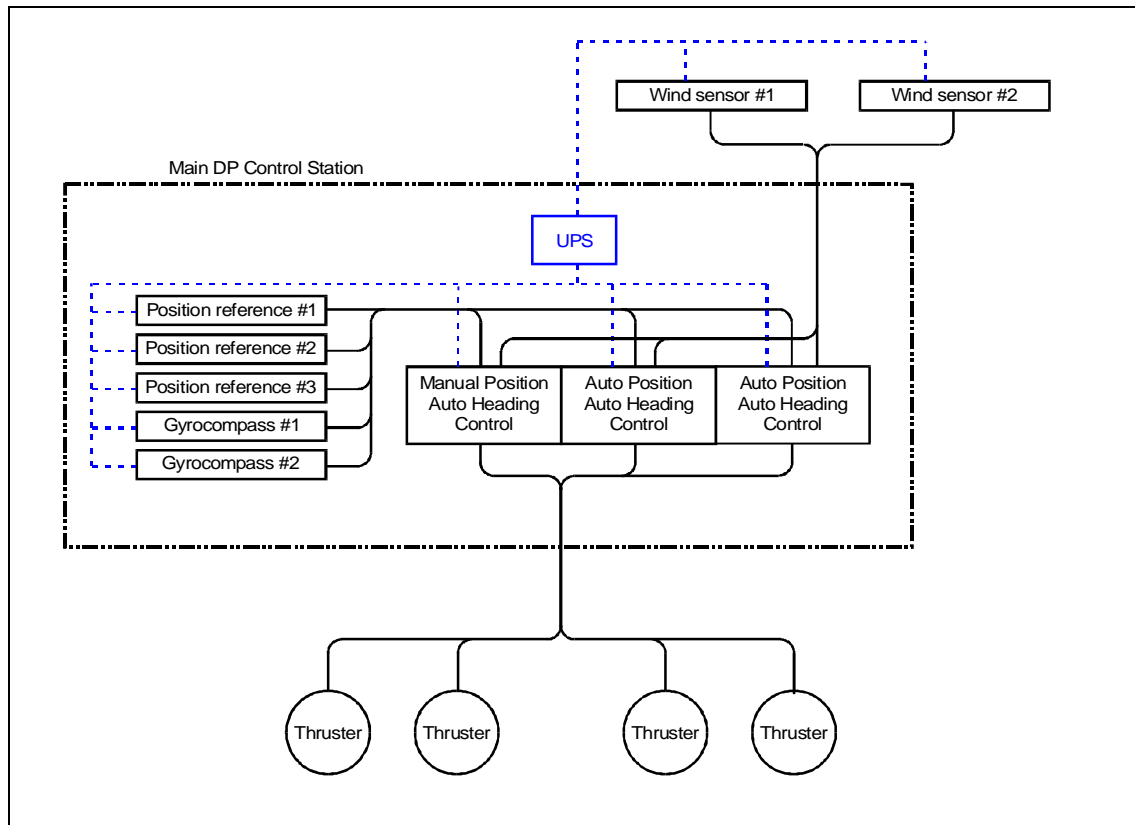

Figure DPS2: Example DPS-2 Control System Arrangement

Finally a DPS-2 or DPS-3 vessel must be provided with a power management system and a consequence analyzer. The power management system automatically ensures that sufficient power is available for essential operations and prevents loads from starting when there is insufficient generator capacity on line. Techniques such as temporarily limiting thrust output and shedding of non-essential loads are applied to prevent black-out and maintain heading and position while additional generating capacity is started and placed on line. The consequence analyzer, on the other hand, continuously monitors the thrust necessary to maintain heading and position under the prevailing environmental conditions and performs calculations to verify that in the event of a single failure there will be sufficient thrust available.

The differences between DPS-3 and DPS-2 are then as follows:

- An additional, back-up control station is required, wherein is situated a third automatic heading and position control system;
- An additional (third) gyro compass is fitted in the back-up control station;
- One of the position reference systems is moved to the back-up control station;
- The back-up control system, its position reference system and gyro compass are supplied from their own, independent uninterruptible power supply.

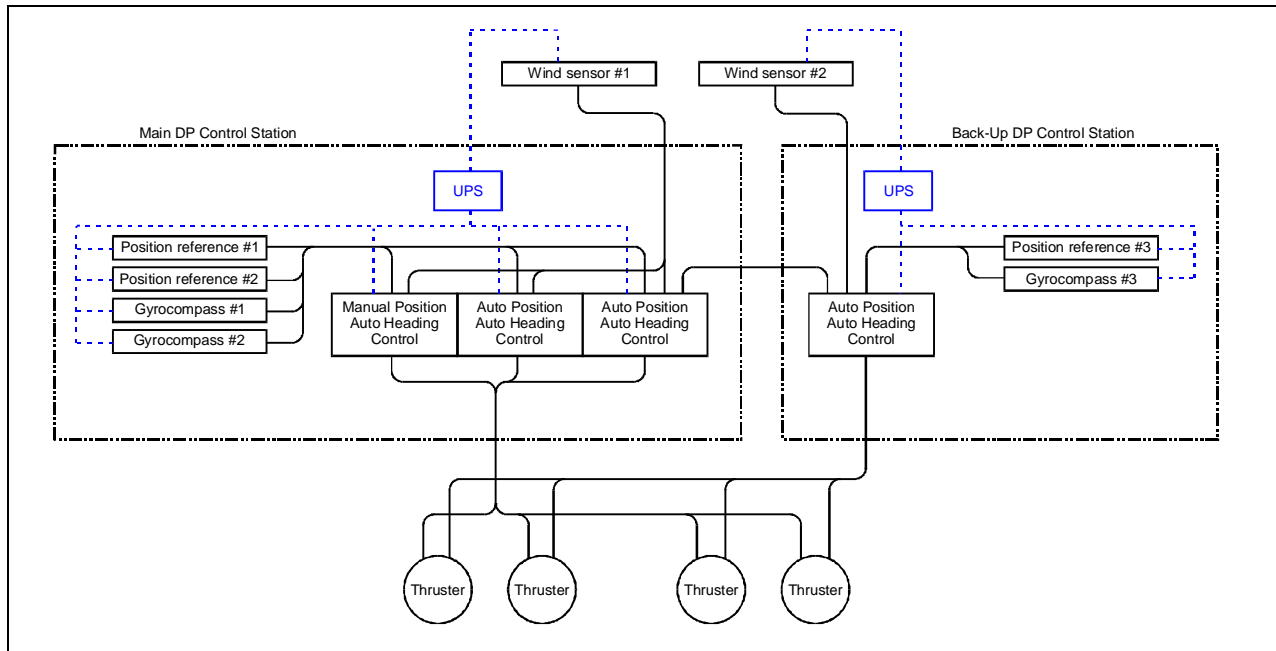

Figure DPS3: Example DPS-3 Control System Arrangement

The back-up control station is required to be situated in a separate compartment, sited and arranged such that no single fault, including fire or flood in one compartment, will render both the main and back-up control systems inoperable. Transfer of control from the main control station to the back-up control station should be manually initiated from the back-up station. A data communications link between the stations means that the back-up control system is constantly updated with information from the on-line system so that it is always aware of the mathematical model, environmental forces, and vessel position and heading, and ready to take over without any elaborate setting up. In addition the information from the back-up station's sensors is available to the main control station. Figure DPS3 shows a typical DPS-3 arrangement.

For DPS-1, DPS-2 and DPS-3 notations loss of the electrical supply to the control and reference systems is not considered acceptable and an uninterruptible power supply with a duration of at least 30 minutes is required. Even though loss of the power supply to the thrusters may occur, the control system should be available immediately when power is restored, i.e. know the model, heading, position, etc. A simple UPS system as would satisfy DPS-1 is shown in figure UPS1.

The ship's ac supply is rectified to dc and used to charge a battery and to supply an inverter. The inverter converts the dc back to ac to supply the actual equipment. In the event of loss of the ship's supply the battery will replace the rectifier output and the ac supply to the equipment will be maintained. Although not strictly required for the DPS-1 notation, an alternative ac supply is also frequently provided to the UPS. In the event of a failure in the rectifier/inverter circuits, the static switch can very rapidly (in the order of milliseconds) change over to the alternative supply. Such a rapid "no-break" change-over is necessary to protect volatile memory circuits contained in the programmable equipment comprising the control systems. The alternative supply provides a higher degree of supply reliability, but there is not 100% redundancy since the static switch is a possible single point of failure.

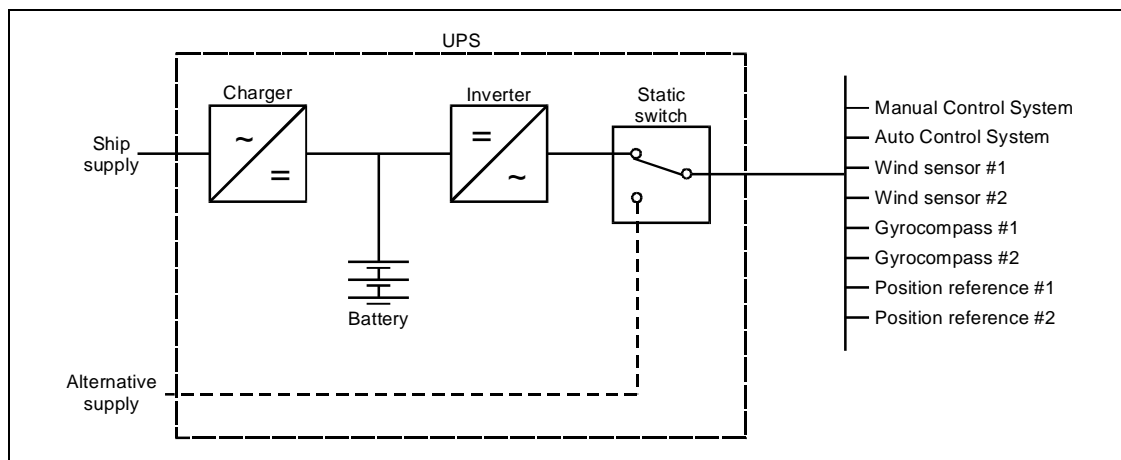

Figure UPS1: Simple UPS Suitable for DPS-1

For DPS-2 and DPS-3 the requirements are more demanding. Since both DPS-2 and DPS-3 require that the system withstand any fault, a failure of the static switch must be considered. An arrangement such as that shown in figure UPS2 would be acceptable for DPS-2 and for the main control station for DPS-3. In addition, for DPS-3, the back-up control system and its reference systems are required to be provided with their own dedicated UPS, the arrangement shown in Figure UPS1 being acceptable for this purpose.

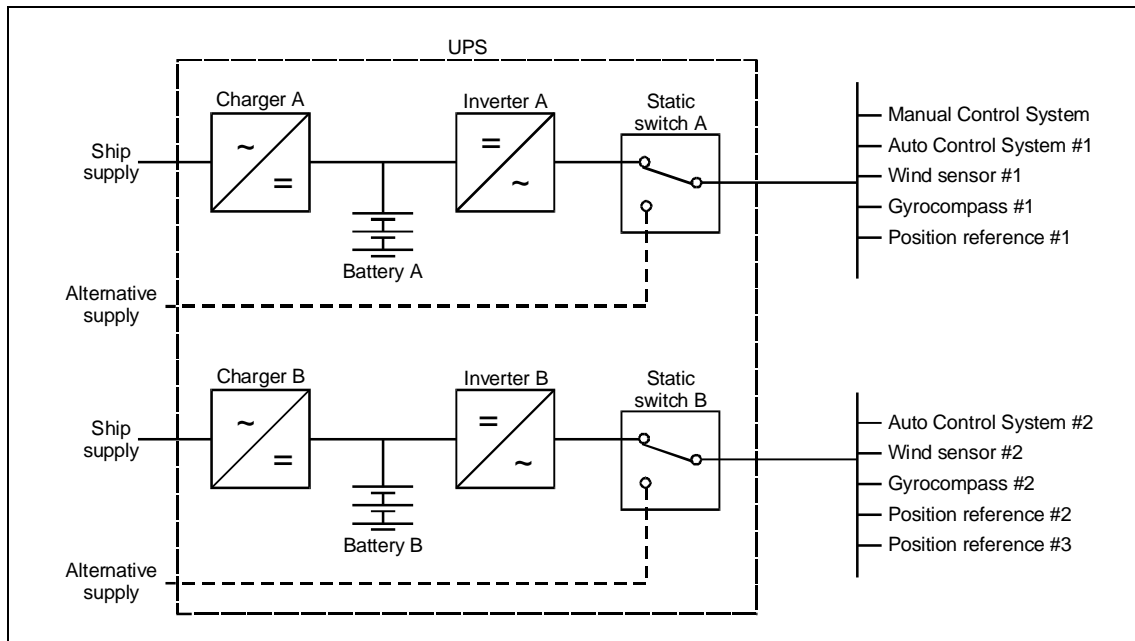

Figure UPS2: Redundant UPS suitable for DPS-2

Electrical Power Generation and Distribution

Electrical power generation and distribution systems are comprehensively covered in the ABS Rules for Steel Vessels, and the ABS Rules for Mobile Offshore Drilling Units, and any vessel requesting a DPS notation must first comply with these requirements. In addition there are requirements specific to DPS-2 and DPS-3 vessels as follows.

For DPS-2 notation, generators and their distribution systems are required to be sized and arranged so that, in the event of any section of bus bar being lost for any reason, sufficient power remains available to supply essential services, critical operational loads (i.e. those necessary to safely terminate operations), and to maintain the vessel's heading and position. Services to generators and their prime movers, such as cooling, lubrication, fuel, air, etc. should also be arranged such that a single failure in these systems will leave sufficient capacity to supply the above loads. As with the control systems, this should be formally proven by means of failure modes and effects analysis.

For DPS-3 notation the above requirements of course remain applicable, however in addition the generators and their distribution systems are required to be sized and arranged in at least two compartments so that, if any compartment is lost due to fire or flood, sufficient power remains available to supply the above mentioned loads.

Design Review and Testing

Classification of a dynamic positioning system consists of two necessary phases: design review and operational testing. In addition, for vessels which are to be assigned a Maltese Cross symbol, e.g. ⚓DPS-3 as opposed to just DPS-3, the systems are surveyed during building.

For the purposes of design review the following documentation concerning the control and power systems is required to be submitted. Following review, one copy is returned to the submitter (manufacturer or shipyard) appropriately stamped, together with a letter indicating any items of concern which require clarification or modification on the part of the submitter, or verification by the Surveyor.

- System description, which is to include a block diagram showing how the components are functionally related;
- Details of the position reference systems and environmental monitoring systems;
- Details of the location of the control system components, including the main control stations, control panels, computers and sensors;
- Details of the DP alarm system and any interconnection with the main alarm system;
- Details of the electrical generation power management system and its interconnection with the control system;
- Details of the consequence analyzer (DPS-2 and DPS-3);
- Details of the electrical supply arrangements to each electrically powered component;
- Details of the thruster remote control system;
- Details of the automatic DP control and monitoring system;
- Environmental force calculations and design safe operating envelope;
- Failure modes and effects analysis (DPS-2 and DPS-3);
- DP operations manual;
- Test schedule.

Control equipment for use as part of a dynamic positioning system intended for units certified for dynamic positioning are required to be certified for suitability in marine atmospheres and tested in the presence of the Surveyor per the testing criteria outlined in Appendix A of the Guide for Thrusters and Dynamic Positioning Systems. Upon completion of the installation of the dynamic positioning system, complete performance tests are carried out to the Surveyor's satisfaction at sea trials. The schedule of these tests, which is to be submitted for review prior to the proposed date of testing, is also designed to demonstrate the level of redundancy established in the FMEA (DPS-2 and DPS-3 systems). Testing will typically include the following general steps, during which the correct operation of alarms and displays will be verified:

- Position and heading movements in manual control.
- Position and heading movements in automatic and mixed control using different combinations of reference systems.
- Verification of the mathematical model by deselecting all reference systems while automatically holding heading and position.
- Simulation of failure of controllers, gyrocompasses, position reference systems, VRUs, wind sensors, thruster signals, etc.
- Simulation of failure of normal control power supplies to verify correct operation and duration of UPS supplies.
- Verification of power management functions, including pitch limitation.
- Endurance testing, i.e. maintaining automatic control at a fixed position and heading for an extended period of time.

Subsequently a general inspection of the DP system equipment is carried out during each year of service, during which the operation and alarms are required to be to the Surveyor's satisfaction.

Table I: Comparison of DPS-0, DPS-1, DPS-2 and DPS-3 requirements for control, reference and power systems.

	DPS-0	DPS-1	DPS-2	DPS-3	
				Main control station	Back-up control station
View of external conditions/activities	Yes	Yes	Yes	Yes	No
Centralized manual position control system with auto heading	1	1	1	1	0
Automatic position and heading control system	0	1	2	2	1
Position reference systems	1	2	3	2	1
Wind sensor	1	2	2*	1**	1
Gyrocompass	1	2	2*	2	1
UPS	No	Yes	Yes	Yes	Yes
Consequence analyzer	No	No	Yes	Yes	No
Redundant power system	No	No	Yes	Yes	
Power management	No	No	Yes	Yes	
Withstand a single component failure	No	No	Yes	Yes	
Withstand loss of a compartment due to fire or flooding	No	No	No	Yes	

* IMO MSC/Circ.645 requires three.

** IMO MSC/Circ.645 requires two.